

CRESCENT
Wiss

CRESCENT
Lufkin

CRESCENT
NICHOLSON

CRESCENT
H.K. PORTER

CRESCENT
JOBBOX

CRESCENT
APEX



CRESCENT

Product Catalog



Trusted by the Trades.

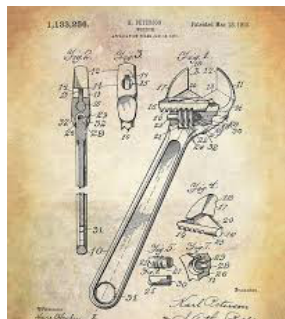

TABLE OF CONTENTS

Fastening	5	Saws	190
Adjustable Wrenches	6	Replacement Blades.....	194
Specialty Adjustable Wrenches.....	12	Measuring	197
Pipe Wrenches	17	Blade Styles	198
Screwdrivers & Nutdrivers	21	Power Tapes	205
Hex Keys	30	Pocket Tapes	212
Mechanic Hand Tool Sets	33	Measuring Wheels.....	214
Multi-Drive.....	34	Long Tapes.....	215
1/4" Drive	47	Squares & Rules.....	222
3/8" Drive	57	Chalk & Reel	229
1/2" Drive	74	Oil Gauging.....	233
3/4" Drive	82	Accessories.....	234
Impact.....	86	Shaping	241
Wrenches.....	91	American Pattern Files.....	242
Torque Wrenches	102	American Pattern Rasps	259
Power Tool Accessories	103	Swiss Pattern Files	262
e-SHOK-Guard®	104	Specialty Files	271
u-GUARD®	105	Accessories.....	272
Insert Bits	109	Striking and Struck	275
Nutsetters.....	115	Hammers	276
Bit Holders.....	116	Demolition Tools	277
Pliers	117	Trade Tools	281
Z2	118	Storage	287
Tongue & Groove	130	Bags.....	288
Solid Joint.....	132	Chests	291
Slip Joint	136	Piano Boxes.....	297
Compound Action.....	137	Field Offices	299
Locking	141	Cabinets	301
Specialty Adjustable.....	145	Safety.....	304
Cutting	147	Vehicle Drawer Storage.....	309
Aviation Snips.....	148	Truck Boxes	310
Tradesman Shears.....	157	Transfer Tanks.....	322
Industrial Shears	160	Accessories & Parts	324
Tinner Snips	169	Index	326
Knives.....	172		
Cutters.....	177		
Rebar Tools	189		

WHY Crescent?

Crescent hand tools have been an essential part of professional toolboxes for over a century. Why? Because at Crescent, we make products for people who depend on their tools to make a living. People who need tools that will stand up to the tough conditions found on every jobsite. People who recognize tools that deliver meaningful performance. Like a tape measure with an industry-leading 14 feet of standout. Or made in USA snips with ten times the cut life of anything else on the market. That's quality to get the job done right and superior performance to save time. Crescent offers thousands of tools, each one made to consistently deliver dependable, high quality results.



1907

Karl Peterson founds the Crescent Tool Company and introduces his revolutionary Crescent® Adjustable Wrench the following year. The unique tool is an instant success and, along with the Ford Model T, soon dominates the market.

1927

Newspapers around the world carry a report that a young aviator named Charles Lindbergh has made the first solo transatlantic flight with a scant cargo of "gasoline, sandwiches, a bottle of water, and a Crescent® wrench and pliers."

1930

At the request of the U.S. Army Air Corps, Crescent® develops Crestoloy steel alloy to make its adjustable wrenches lighter and stronger. By 1938, Crescent® is manufacturing thousands of Crestoloy tools for the Air Corps. When the country enters World War II, the plant operates around-the-clock with all output going to the war effort.

1964

Crescent® vans begin traveling the country, visiting distributors and showing new products. This is a tradition that continues to this day.

1965

The media reports that Crescent® tools are aboard the first manned Gemini space flight.

1997

The Crescent® adjustable wrench receives its first major redesign in over 50 years, with a wider, more comfortable handle and increased jaw opening capacity over the entire line.

2018

To easier identify the Crescent®-quality tools, the line expands to include five iconic brands: Wiss® shears and snips, Lufkin® measuring products, Nicholson® files and saws, HK Porter® heavy-duty cutting tools and JOBOX® on-site and truck storage. Together, Crescent® Tools is formed and provides professional tradesman thousands of jobsite solutions all under one unified brand.

2019

Crescent Wiss® introduces its Next Generation Aviation Snips. The new snips last 60% longer and require 20% less force to cut on average compared to the same snips from just five years earlier. Crescent APEX® industrial bits are added to the Crescent® family of tools

Innovation in the past and for the future.

From our beginnings with the original Crescent adjustable wrench and continuing through today, we are always looking for ways to make our tools better and create new ways to help tradespeople be more productive...

2020



Z2: Giving new power to pliers.

Crescent Z2 pliers take gripping and cutting to new levels of performance. Z2 Auto Bite™ pliers feature one-handed automatic adjustment, making them perfect for gripping in tight spaces, while the Six Zone head of Z2 Long Nose pliers gives them the ability to cut, grip, and turn better than any long nose we've ever made. Each plier in the Z2 line has features that make it the new best performer in its class.



Shockforce: Making a tape measure for the trades.

Pro tool users are tough to please. So when we said new Shockforce tapes were the toughest tapes to ever hit a jobsite, we met some skepticism. But after using the tapes with the ability to survive a 100-foot drop, skeptics turned into supporters. Shockforce and Shockforce Nite Eye, with its high visibility green-on-matte black blade, have become new standards in tape measures for trade professionals.



Chalk Reels: Rethinking a simple concept.

Chalk reel design had remained the same for years before Crescent listened to users and developed new solutions to nagging problems. Our new 100-Foot Professional Chalk Reel now offers three innovative features that put it ahead of any other reel on the market: A one-way valve makes refilling quick and clean, a locking hub makes snaps neat and fast, and a nesting end hook prevents tool bag tangles.

Fastening

Wrenches • Screwdrivers
Nutdrivers • Hex Keys



Innovative solutions for better products. That's Crescent.

3 Pc. Adjustable Wrench Set

- The original adjustable wrench, made by the world-famous Crescent® brand
- Laser etched scale in both SAE and metric sizes allows easy fastener size identification
- Larger knurl provides a tighter jaw fit, is easier to adjust and is less likely to bind up
- Hex jaw design reduces slippage by gripping fasteners tightly
- Large capacity 15/16", 24mm [6"], 1-1/8", 29mm [8"] and 1-5/16", 34mm [10"] jaws fit a wide range of fastener sizes
- Wider handle improves comfort and reduces fatigue
- Heat-treated forged alloy steel for toughness and durability
- Tension spring stabilizes jaw and allows easy knurl adjustment
- Chrome plated finish wipes clean easily and resists rust and corrosion
- Polished head and satin finished handle



Cat. No.	Included Storage	Product Weight
AC3PC	None	2.200 lb

Cat. No.	Description
AC26VS	6" Adjustable Wrench
AC28VS	8" Adjustable Wrench
AC210VS	10" Adjustable Wrench

2 Pc. Adjustable Wrench Set

- The original adjustable wrench, made by the world-famous Crescent® brand
- Laser etched scale in both SAE and metric sizes allows easy fastener size identification
- Larger knurl provides a tighter jaw fit, is easier to adjust and is less likely to bind up
- Hex jaw design reduces slippage by gripping fasteners tightly
- Large capacity 1-1/8", 29mm [8"] and 1-1/2", 39mm [12"] jaws fit a wide range of fastener sizes
- Wider handle improves comfort and reduces fatigue
- Heat-treated forged alloy steel for toughness and durability
- Tension spring stabilizes jaw and allows easy knurl adjustment
- Chrome plated finish wipes clean easily and resists rust and corrosion
- Polished head and satin finished handle



Cat. No.	Included Storage	Product Weight
AC2812VS	None	2.45 lb

Cat. No.	Description
AC28VS	8" Adjustable Wrench
AC212VS	12" Adjustable Wrench

Adjustable Wrenches

- The original adjustable wrench, made by the world-famous Crescent® brand
- Laser etched scale in both SAE and metric sizes allows easy fastener size identification
- Larger knurl provides a tighter jaw fit, is easier to adjust and is less likely to bind up
- Hex jaw design reduces slippage by gripping fasteners tightly
- Wider handle improves comfort and reduces fatigue
- Heat-treated forged alloy steel for toughness and durability
- Tension spring stabilizes jaw and allows easy knurl adjustment
- Chrome plated finish wipes clean easily and resists rust and corrosion
- Polished head and satin finished handle



Cat. No.	Overall Length	Capacity Diameter Max	Packaging	Product Weight
AC24VS	4 in	0.500 in	Carded	0.16 lb
AC24BK	4 in	0.500 in	Bagged	0.13 lb
AC26VS	6 in	0.937 in	Carded	0.38 lb
AC26BK	6 in	0.937 in	Bagged	0.34 lb
AC28VS	8 in	1.125 in	Carded	0.62 lb
AC28BK	8 in	1.125 in	Bagged	0.60 lb
AC210VS	10 in	1.312 in	Carded	1.06 lb
AC210BK	10 in	1.312 in	Boxed	1.20 lb
AC212VS	12 in	1.500 in	Carded	1.81 lb
AC212BK	12 in	1.500 in	Boxed	1.92 lb

Tapered Handle Adjustable Wrenches

- The original adjustable wrench, made by the world-famous Crescent® brand
- Laser etched scale in both SAE and metric sizes allows easy fastener size identification
- Larger knurl provides a tighter jaw fit, is easier to adjust and is less likely to bind up
- Hex jaw design reduces slippage by gripping fasteners tightly
- Heat-treated forged alloy steel for toughness and durability
- Tension spring stabilizes jaw and allows easy knurl adjustment
- Tapered handle for better two-handed grip and less weight
- Chrome plated finish wipes clean easily and resists rust and corrosion
- Polished head and satin finished handle



Cat. No.	Overall Length	Capacity Diameter Max	Packaging	Product Weight
AC215VS	15 in	1.687 in	Carded	3.00 lb
AC215BK	15 in	1.687 in	Boxed	3.00 lb
AC218VS	18 in	2.062 in	Carded	4.92 lb
AC218BK	18 in	2.062 in	Boxed	4.92 lb
AC224VS	24 in	2.437 in	Carded	8.71 lb
AC224BK	24 in	2.437 in	Boxed	8.71 lb

3 Pc. Cushion Grip Adjustable Wrench Set

- The original adjustable wrench, made by the world-famous Crescent® brand
- Laser etched scale in both SAE and metric sizes allows easy fastener size identification
- Larger knurl provides a tighter jaw fit, is easier to adjust and is less likely to bind up
- Hex jaw design reduces slippage by gripping fasteners tightly
- Large capacity 15/16", 24mm [6"], 1-1/8", 29mm [8"] and 1-5/16", 34mm [10"] jaws fit a wide range of fastener sizes
- Heat-treated forged alloy steel for toughness and durability
- Tension spring stabilizes jaw and allows easy knurl adjustment
- Chrome plated finish wipes clean easily and resists rust and corrosion
- Proportioned dimensions optimize strength and minimize weight
- Cushioned ergonomic handle increases comfort and reduces fatigue



Cat. No.	Included Storage	Product Weight
AC26810CV	Pouch	2.45 lb

Cat. No.	Description
AC26CVS	6" Adjustable Cushion Grip Wrench
AC28CVS	8" Adjustable Cushion Grip Wrench
AC210CVS	10" Adjustable Cushion Grip Wrench

2 Pc. Cushion Grip Adjustable Wrench Set

- The original adjustable wrench, made by the world-famous Crescent® brand
- Laser etched scale in both SAE and metric sizes allows easy fastener size identification
- Larger knurl provides a tighter jaw fit, is easier to adjust and is less likely to bind up
- Hex jaw design reduces slippage by gripping fasteners tightly
- Large capacity 15/16", 24mm [6"] and 1-5/16", 34mm [10"] jaws fit a wide range of fastener sizes
- Heat-treated forged alloy steel for toughness and durability
- Tension spring stabilizes jaw and allows easy knurl adjustment
- Chrome plated finish wipes clean easily and resists rust and corrosion
- Proportioned dimensions optimize strength and minimize weight
- Cushioned ergonomic handle increases comfort and reduces fatigue



Cat. No.	Included Storage	Product Weight
AC2610CVS	None	1.850 lb

Cat. No.	Description
AC26CVS	6" Adjustable Cushion Grip Wrench
AC210CVS	10" Adjustable Cushion Grip Wrench

Cushion Grip Adjustable Wrenches

- The original adjustable wrench, made by the world-famous Crescent® brand
- Laser etched scale in both SAE and metric sizes allows easy fastener size identification
- Larger knurl provides a tighter jaw fit, is easier to adjust and is less likely to bind up
- Hex jaw design reduces slippage by gripping fasteners tightly
- Heat-treated forged alloy steel for toughness and durability
- Tension spring stabilizes jaw and allows easy knurl adjustment
- Chrome plated finish wipes clean easily and resists rust and corrosion
- Proportioned dimensions optimize strength and minimize weight
- Cushioned ergonomic handle increases comfort and reduces fatigue



Cat. No.	Overall Length	Capacity Diameter Max	Packaging	Product Weight
AC24CVS	4 in	0.500 in	Carded	0.15 lb
AC26CVS	6 in	0.937 in	Carded	0.38 lb
AC28CVS	8 in	1.125 in	Carded	0.62 lb
AC28CBK	8 in	1.125 in	Bagged	0.60 lb
AC210CVS	10 in	1.312 in	Carded	1.06 lb
AC210CBK	10 in	1.312 in	Boxed	1.20 lb
AC212CVS	12 in	1.500 in	Carded	1.81 lb
AC212CBK	12 in	1.500 in	Boxed	1.92 lb

Black Oxide Adjustable Wrenches

- The original adjustable wrench, made by the world-famous Crescent® brand
- Laser etched scale in both SAE and metric sizes allows easy fastener size identification
- Larger knurl provides a tighter jaw fit, is easier to adjust and is less likely to bind up
- Hex jaw design reduces slippage by gripping fasteners tightly
- Heat-treated forged alloy steel for toughness and durability
- Tension spring stabilizes jaw and allows easy knurl adjustment
- Ergonomic handle increases comfort and reduces fatigue
- Proportioned dimensions for greatest strength and minimum weight
- Black oxide finish resists corrosion



Cat. No.	Overall Length	Capacity Diameter Max	Packaging	Product Weight
AT24VS	4 in	0.500 in	Carded	0.15 lb
AT24BK	4 in	0.500 in	Bagged	0.13 lb
AT26VS	6 in	0.937 in	Carded	0.38 lb
AT26BK	6 in	0.937 in	Bagged	0.34 lb
AT28VS	8 in	1.125 in	Carded	0.62 lb
AT28BK	8 in	1.125 in	Bagged	0.60 lb
AT210VS	10 in	1.312 in	Carded	1.06 lb
AT210BK	10 in	1.312 in	Boxed	1.06 lb
AT212VS	12 in	1.500 in	Carded	1.81 lb
AT212BK	12 in	1.500 in	Boxed	1.92 lb

Black Oxide Tapered Handle Adjustable Wrenches

- The original adjustable wrench, made by the world-famous Crescent® brand
- Laser etched scale in both SAE and metric sizes allows easy fastener size identification
- Larger knurl provides a tighter jaw fit, is easier to adjust and is less likely to bind up
- Hex jaw design reduces slippage by gripping fasteners tightly
- Heat-treated forged alloy steel for toughness and durability
- Tension spring stabilizes jaw and allows easy knurl adjustment
- Tapered handle for better two-handed grip and less weight
- Proportioned dimensions for greatest strength and minimum weight
- Black oxide finish resists corrosion



Cat. No.	Overall Length	Capacity Diameter Max	Packaging	Product Weight
AT215BK	15 in	1.688 in	Boxed	3.20 lb
AT218BK	18 in	2.063 in	Boxed	5.29 lb

2 Pc. Black Oxide Cushion Grip Adjustable Wrench Set

- The original adjustable wrench, made by the world-famous Crescent® brand
- Laser etched scale in both SAE and metric sizes allows easy fastener size identification
- Larger knurl provides a tighter jaw fit, is easier to adjust and is less likely to bind up
- Hex jaw design reduces slippage by gripping fasteners tightly
- Large capacity 15/16", 24mm [6"] and 1-5/16", 34mm [10"] jaws fit a wide range of fastener sizes
- Heat-treated forged alloy steel for toughness and durability
- Tension spring stabilizes jaw and allows easy knurl adjustment
- Black oxide finish resists rust or corrosion and wipes clean easily
- Proportioned dimensions optimize strength and minimize weight
- Cushioned ergonomic handle increases comfort and reduces fatigue



Cat. No.	Included Storage	Product Weight
AT2610CVS	None	2.00 lb

Cat. No.	Description
AT26CVS	6" Adjustable Black Oxide Cushion Grip Wrench
AT210CVS	10" Adjustable Black Oxide Cushion Grip Wrench

Black Oxide Cushion Grip Adjustable Wrenches

- The original adjustable wrench, made by the world-famous Crescent® brand
- Laser etched scale in both SAE and metric sizes allows easy fastener size identification
- Larger knurl provides a tighter jaw fit, is easier to adjust and is less likely to bind up
- Hex jaw design reduces slippage by gripping fasteners tightly
- Heat-treated forged alloy steel for toughness and durability
- Tension spring stabilizes jaw and allows easy knurl adjustment
- Black oxide finish resists rust or corrosion and wipes clean easily
- Proportioned dimensions optimize strength and minimize weight
- Cushioned ergonomic handle increases comfort and reduces fatigue



Cat. No.	Overall Length	Capacity Diameter Max	Packaging	Product Weight
AT26CVS	6 in	0.937 in	Carded	0.34 lb
AT28CVS	8 in	1.125 in	Carded	0.62 lb
AT210CVS	10 in	1.312 in	Carded	1.06 lb
AT212CVS	12 in	1.500 in	Carded	1.81 lb

Black Oxide Construction Wrenches

- The original adjustable wrench, made by the world-famous Crescent® brand
- Laser etched scale in both SAE and metric sizes allows easy fastener size identification
- Larger knurl provides a tighter jaw fit, is easier to adjust and is less likely to bind up
- Hex jaw design reduces slippage by gripping fasteners tightly
- Heat-treated forged alloy steel for toughness and durability
- Tension spring stabilizes jaw and allows easy knurl adjustment
- Round, tapered tang for easy alignment of bolt holes
- Black oxide finish resists rust or corrosion and wipes clean easily
- Proportioned dimensions optimize strength and minimize weight



Cat. No.	Overall Length	Capacity Diameter Max	Packaging	Product Weight
AT210SPUD	10 in	1.125 in	Carded	0.950 lb
AT215SPUD	16 in	1.500 in	Carded	2.350 lb

Crescent Wide Jaw Adjustable Wrenches

These wrenches really punch above their weight when it comes to strength and jaw capacity. They open wide to work on fasteners that would need the next larger size standard adjustable. For example, a 10-inch Crescent Wide Jaw has the same strength and jaw capacity as a 12-inch standard adjustable, so they save space and weight in your toolbox. Lighten your load with these new tools from Crescent ... the original name in adjustable wrenches.

Exceeds ASME Requirements
Meets performance standards of the next larger size

Black Phosphate and Lacquer Finish
Resists rust and corrosion

Serrations on Jaws
Gives up to 4X more torque than traditional adjustables

Larger Knurl
For easier adjustment and tighter jaw fit, won't bind up

Laser Etched Scale
SAE and Metric, allows easy determination of fastener size

Wider Jaw Opening
Allows use with a greater range of fastener sizes than traditional adjustables.



ATWJ210VS

4X MORE TORQUE

SUPER DUTY



EXTRA WIDE JAW

NEXT LEVEL



2 Pc. Wide Jaw Adjustable Wrench Set

- Each wrench meets the ASME performance requirements for the next size up [Example: 6" wrench meets the requirements for an 8" wrench]
- Micro-serrations on the jaws provide a tighter grip on the fastener thus helping to generate 4x more torque than traditional adjustable wrenches
- Laser etched scale in both SAE and metric sizes allows easy fastener size identification
- Larger knurl provides a tighter jaw fit, is easier to adjust and is less likely to bind up
- Black phosphate and lacquer finish help to resist rust and prevent corrosion for better durability



SAE mm

Cat. No.	Included Storage	Product Weight
ATWJ2610VS	None	1.72 lb

Cat. No.	Description
ATWJ26VS	6" Wide Jaw Adjustable Wrench
ATWJ210VS	10" Wide Jaw Adjustable Wrench

Wide Jaw Adjustable Wrenches

- Each wrench meets the ASME performance requirements for the next size up [Example: 6" wrench meets the requirements for an 8" wrench]
- Micro-serrations on the jaws provide a tighter grip on the fastener thus helping to generate 4x more torque than traditional adjustable wrenches
- Laser etched scale in both SAE and metric sizes allows easy fastener size identification
- Larger knurl provides a tighter jaw fit, is easier to adjust and is less likely to bind up
- Black phosphate and lacquer finish help to resist rust and prevent corrosion for better durability



SAE mm

Cat. No.	Overall Length	Capacity Diameter Max	Product Weight
ATWJ26VS	6 in	1.125 in	0.49 lb
ATWJ28VS	8 in	1.312 in	0.79 lb
ATWJ210VS	10 in	1.500 in	1.26 lb
ATWJ212VS	12 in	1.750 in	1.96 lb

SPECIALTY ADJUSTABLES

Locking Adjustable Wrench

- The original adjustable wrench, made by the world-famous Crescent® brand
- Laser etched scale in both SAE and metric sizes allows easy fastener size identification
- The versatility of an adjustable wrench and the gripping power of a locking plier
- Anti-slip adjustable jaw opens to 1" to fit a wide variety of fasteners
- Delivers twice the gripping power on rounded fasteners
- Locking handle tightly grips fasteners, reduces slippage on rounded fasteners
- Jaw design features gripping teeth and 14 locking positions for enhanced gripping power
- Quick release lever allows for easy disengagement
- Dual material handle for maximum comfort and control
- Chrome plated finish wipes clean easily and resists rust and corrosion



Cat. No.	Overall Length	Capacity Diameter Max	Product Weight
ACL10VS	10 in	1.312 in	1.480 lb

2 Pc. RapidSlide™ Adjustable Wrench Set

- Slide button mechanism in handle for quick, fast adjustment
- Debris shield protects slide mechanism and maintains a smooth operation
- Laser etched scale in both SAE and metric sizes allows easy fastener size identification
- Large capacity 15/16, 24mm [8"] and 1-3/16, 30mm [10"] jaws fit a wide range of fastener sizes
- Heat-treated forged alloy steel for toughness and durability
- Chrome plated finish wipes clean easily and resists rust and corrosion
- Polished head and satin finished handle



Cat. No.	Included Storage	Product Weight
AC610RS	None	1.15 lb



Cat. No.	Description
-	6" RapidSlide™ Adjustable Wrench
-	10" RapidSlide™ Adjustable Wrench

Ratcheting Adjustable Flex Lock Wrench

- The original adjustable wrench, made by the world-famous Crescent® brand
- Laser etched scale in both SAE and metric sizes allows easy fastener size identification
- Larger knurl provides a tighter jaw fit, is easier to adjust and is less likely to bind up
- Heat-treated forged alloy steel for toughness and durability
- Large capacity 1-1/8", 29mm hex jaw design reduces slippage
- Ratcheting jaw keeps jaws secured on fasteners, making jobs faster and easier
- Ratcheting on/off selector allows use as a traditional adjustable wrench
- 180° indexing handle locks in 12 different positions
- Chrome plated finish wipes clean easily and resists rust and corrosion
- Polished head and satin finished handle



Cat. No.	Overall Length	Capacity Diameter Max	Product Weight
ACFR8VS	8 in	1.187 in	0.830 lb

Automobile Adjustable Wrenches

- Smooth jaws won't mar easily-damaged fastener surfaces such as chrome or brass
- Wider jaw capacity than traditional pipe wrenches
- Slim profile head design allows better access to tight areas
- Heat-treated forged alloy steel for toughness and durability
- Steel handle naturally absorbs shock
- Strong I-beam handle construction
- Chrome plated finish wipes clean easily and resists rust and corrosion



Cat. No.	Overall Length	Capacity Diameter Max	Product Weight
C79H	9 in	2.750 in	1.01 lb
C711H	11 in	3.000 in	1.50 lb
C715	15 in	3.625 in	3.20 lb
C718	18 in	4.375 in	4.60 lb

Chain Wrenches

- Double-action grip force allows use in either direction for tightening or loosening
- Excels in low-access areas where ordinary pipe wrenches will not fit
- Concave-cut teeth grip tightly and can be easily sharpened if needed
- Excellent for pipe fittings
- Steel handle naturally absorbs shock
- Strong I-beam handle construction
- Chrome plated finish wipes clean easily and resists rust and corrosion



Cat. No.	Chain Length	Overall Length	Pipe Size Max	Rplc. Part	Product Weight
CW12H	16.27 in	12.25 in	4 in	CW12C	1.85 lb
CW15	19.64 in	14.81 in	5 in	CW15C	2.75 lb
CW24	24.14 in	24.00 in	6 in	CW24C	3.60 lb

11 Pc. X6™ Pass-Thru™ Adjustable Wrench Set

- Versatile fastening tool that offers the user multiple fastening options from a single tool design
- Traditional 8" adjustable wrench with laser etched SAE/metric scales and a wide jaw opening
- Remove and reverse the jaw for pipe work. Serrations on the inside edge form a deep tooth pattern that holds pipe tightly and reduces slipping
- Pass-Thru™ reversible ratcheting system functions over long threaded rods where normal ratchets and sockets won't fit
- Every Pass-Thru™ socket does the job of a standard and a deep socket combined
- Universal design fits 6 fastener types - Hex, Square, 12pt, E-Torx, Partially Rounded Hex, and Spline
- Forged alloy steel for exceptional toughness and durability
- Black phosphate finish resists corrosion
- Includes tray for storage and organization



Cat. No.	Included Storage	Product Weight
CPTAW8	Tray	1.984

Cat. No.	Description	Cat. No.	Description
-	8" Pass-Thru™ Adjustable Wrench	-	3/8" Drive Pass-Thru™ Spline Socket 19/32" (15mm)
-	3/8" Drive Pass-Thru™ Spline Socket 3/8" (10mm)	-	3/8" Drive Pass-Thru™ Spline Socket 5/8" (16mm)
-	3/8" Drive Pass-Thru™ Spline Socket 7/16" (11mm)	-	3/8" Drive Pass-Thru™ Spline Socket 11/16" (17mm)
-	3/8" Drive Pass-Thru™ Spline Socket 15/32" (12mm)	-	3/8" Drive Pass-Thru™ Spline Socket 23/32" (18mm)
-	3/8" Drive Pass-Thru™ Spline Socket 1/2" (13mm)	-	3/8" Drive Pass-Thru™ Spline Socket 3/4" (19mm)
-	3/8" Drive Pass-Thru™ Spline Socket 9/16" (14mm)		



More Power At Every Turn

These new Crescent Pipe Wrenches have been redesigned from the ground up to be lighter, quicker to adjust, and more comfortable to use. But even more, they've been designed to deliver the most powerful pipe grip ever with our new straight wrenches offering larger bite surfaces and exclusive K9™ 30-degree angle access jaws that give you massive turning power, even in the tightest, most restricted situations.

Straight Pipe Wrenches come in both cast aluminum and cast iron. Aluminum models are up to 40% lighter than typical cast iron wrenches with thicker cross-sections in high-stress areas for exceptional strength. Our cast iron wrenches have also been optimized for strength, weighing up to 10% less than competitive products.

Our Self-Adjusting Pipe Wrenches offer compact size, light weight, and a jaw design that locks open for easier placement onto pipes in tight spots.



2X Faster Adjustment Speed
Adjustment ring thread pitch angled for faster opening and closing of wrench jaw

CAPW18

Best Grip
Handle shape optimized for maximum power and user comfort

40% Less Weight
To help reduce user fatigue, weight has been cut in low stress areas of aluminum wrenches, making them up to 40% lighter than cast iron wrenches. Our cast iron wrenches have also been design optimized to be up to 10% lighter than competitive wrenches.

Best Access
K9™ Jaw Technology allows teeth to bite in an arc of 30 degrees — much greater than typical pipe wrench operation limits — for greater access in tight spaces

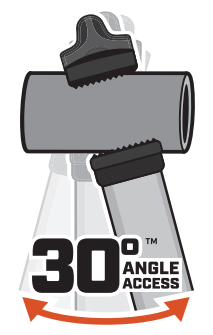

Patent Pending

**30° ANGLE-ACCESS
LARGEST
BITE SURFACE**



**RAPID
ADJUST
JAWS
2X FASTER**

**MORE THAN
40%
LIGHTER
THAN CAST IRON**

*Aluminum models

Aluminum K9™ Pipe Wrenches

- K9™ jaw technology allows teeth to bite in an arc of 30 degrees for greater access in tight spaces
- 25% larger bite surface provides maximum grip helping to increase tooth durability and life
- Adjustment ring thread pitch angled for 2x faster opening and closing of wrench jaw
- 40% less weight helps reduce user fatigue
- Handle shape optimized for maximum power and user comfort
- Exceeds federal torque load specification by over 140% for maximum strength and durability



Cat. No.	Overall Length	Capacity Diameter Max	Pipe Size Max	Rplc. Part	Rplc. Part	Product Weight
CAPW14	11.75 in	2.375 in	2.0 in	C14HOOK	C14HEEL	2.143 lb
CAPW18	14.75 in	2.875 in	2.5 in	C18HOOK	C18HEEL	3.370 lb

Aluminum SLIM JAW™ Pipe Wrench

- SLIM JAW™ delivers best-in-class 2x access when working in tight spaces
- Adjustment ring thread pitch angled for 2x faster opening and closing of wrench jaw
- Excellent for turning pipes in limited access areas
- 40% less weight helps reduce user fatigue
- Handle shape optimized for maximum power and user comfort
- Exceeds federal torque load specification by over 140% for maximum strength and durability



Cat. No.	Overall Length	Capacity Diameter Max	Pipe Size Max	Rplc. Part	Rplc. Part	Product Weight
CAPW10S	9 in	1.9 in	1.5 in	C10HOOK	C10HEEL	0.980 lb

Aluminum Pipe Wrench

- Adjustment ring thread pitch angled for 2x faster opening and closing of wrench jaw
- 40% less weight helps reduce user fatigue
- Handle shape optimized for maximum power and user comfort
- High strength forged jaws
- Exceeds federal torque load specification by over 140% for maximum strength and durability



Cat. No.	Overall Length	Capacity Diameter Max	Pipe Size Max	Rplc. Part	Rplc. Part	Product Weight
CAPW24	20.5 in	3.5 in	3 in	C24HOOK	C24HEEL	4.988 lb

Aluminum K9™ Jaw Long Handle Pipe Wrench

- K9™ jaw technology allows teeth to bite in an arc of 30 degrees for greater access in tight spaces
- 25% larger bite surface provides maximum grip helping to increase tooth durability and life
- Adjustment ring thread pitch angled for 2x faster opening and closing of wrench jaw
- 40% less weight helps reduce user fatigue
- Handle shape optimized for maximum power and user comfort
- Exceeds federal torque load specification by over 140% for maximum strength and durability



Cat. No.	Overall Length	Capacity Diameter Max	Pipe Size Max	Rplc. Part	Rplc. Part	Product Weight
CAPW14L	17.5 in	2.375 in	2 in	C14HOOK	C14HEEL	2.632 lb

Cast Iron K9™ Pipe Wrenches

- K9™ jaw technology allows teeth to bite in an arc of 30 degrees for greater access in tight spaces
- 25% larger bite surface provides maximum grip helping to increase tooth durability and life
- Adjustment ring thread pitch angled for 2x faster opening and closing of wrench jaw
- Optimized cast iron design is up to 10% lighter than competitive wrenches
- Handle shape optimized for maximum power and user comfort
- Exceeds federal torque load specification by over 160% for maximum strength and durability



Cat. No.	Overall Length	Capacity Diameter Max	Pipe Size Max	Rplc. Part	Rplc. Part	Product Weight
CIPW14	11.75 in	2.375 in	2.0 in	C14HOOK	C14HEEL	2.510 lb
CIPW18	14.75 in	2.875 in	2.5 in	C18HOOK	C18HEEL	5.690 lb

Cast Iron SLIM JAW™ Pipe Wrench

- SLIM JAW™ delivers best-in-class 2x access when working in tight spaces
- Adjustment ring thread pitch angled for 2x faster opening and closing of wrench jaw
- Excellent for turning pipes in limited access areas
- Optimized cast iron design is up to 10% lighter than competitive wrenches
- Handle shape optimized for maximum power and user comfort
- Exceeds federal torque load specification by over 140% for maximum strength and durability



Cat. No.	Overall Length	Capacity Diameter Max	Pipe Size Max	Rplc. Part	Rplc. Part	Product Weight
CIPW10S	9 in	1.9 in	1.5 in	C10HOOK	C10HEEL	1.740 lb

Self-Adjusting Dual Material Pipe Wrench

- Self-adjusting head design instantly grips or releases, providing fast ratcheting action
- Double the gripping power of traditional tongue-and-groove pliers
- Extended lower jaw increases access and allows for quick pipe grip in confined spaces
- Locking jaw allows users to lock the jaw in the open position to quickly enter and exit pipe turning applications
- Unique angled tooth configuration grips tighter
- 20% wider jaw for improved gripping power
- Slim profile head design allows better access to tight areas
- Ideal for most surfaces, including black iron, galvanized, PVC and copper pipe, as well as nuts, bolts, and couplings
- Dual material grip provides added comfort and durability
- Black oxide finish wipes clean easily and resists rust or corrosion



Cat. No.	Overall Length	Capacity Diameter Max	Pipe Size Min	Pipe Size Max	Product Weight
CPW12	12.09 in	1.5 in	0.675 in	1.5 in	1.29 lb

Self-Adjusting Steel Pipe Wrenches

- Self-adjusting head design instantly grips or releases, providing fast ratcheting action
- Double the gripping power of traditional tongue-and-groove pliers
- Extended lower jaw increases access and allows for quick pipe grip in confined spaces
- Locking jaw allows users to lock the jaw in the open position to quickly enter and exit pipe turning applications
- Unique angled tooth configuration grips tighter
- 20% wider jaw for improved gripping power
- Slim profile head design allows better access to tight areas
- Ideal for most surfaces, including black iron, galvanized, PVC and copper pipe, as well as nuts, bolts, and couplings



Cat. No.	Overall Length	Capacity Diameter Max	Pipe Size Min	Pipe Size Max	Product Weight
CPW12S	11.94 in	1.5 in	0.675 in	1.5 in	1.300 lb
CPW16S	16.17 in	2.5 in	1.250 in	2.5 in	3.100 lb

20 Pc. Acetate Screwdriver Set

- Chrome plated shafts and blades for increased corrosion resistance
- Blade tips are designed to ensure tighter tolerance and fit while adding convenience when starting fasteners
- Ergonomic tri-lobe extruded acetate handles provide increased comfort and maximized torque for driving and loosening fasteners
- Easy-to-clean, chemical-resistant acetate handles stand up to all conditions
- Phillips® and Torx® screwdrivers feature round blades; slotted screwdrivers feature square blades
- Color-coded handles help to quickly identify driver type
- Stamped markings on the handle denote the size of driver to help you quickly identify the needed tool



Cat. No.	Included Storage	Product Weight
CPS20PCSET	None	3.570 lb



Cat. No.	Description	Cat. No.	Description
CP0212	#0 x 2-1/2" Phillips® Acetate Screwdriver	CS3164	3/16" x 4" Slotted Acetate Screwdriver
CP1112	#1 x 1-1/2" Phillips® Acetate Stubby Screwdriver	CS3166	3/16" x 6" Slotted Acetate Screwdriver
CP13	#1 x 3" Phillips® Acetate Screwdriver	CS3169	3/16" x 9" Slotted Acetate Screwdriver
CP2112	#2 x 1-1/2" Phillips® Acetate Stubby Screwdriver	-	1/4" x 6" Slotted Acetate Screwdriver
CP24N	#2 x 4" Phillips® Acetate Screwdriver	CT103	T10 x 3" Torx® Acetate Screwdriver
CP26	#2 x 6" Phillips® Acetate Screwdriver	CT153	T15 x 3" Torx® Acetate Screwdriver
CP28	#2 x 8" Phillips® Acetate Screwdriver	CT203	T20 x 3" Torx® Acetate Screwdriver
CS182	1/8" x 2" Slotted Acetate Screwdriver	CT254	T25 x 4" Torx® Acetate Screwdriver
CS184	1/8" x 4" Slotted Acetate Screwdriver	CT304	T30 x 4" Torx® Acetate Screwdriver
CS316112	3/16" x 1-1/2" Slotted Acetate Stubby Screwdriver	-	4-in-1 Pocket Screwdriver

6 Pc. Acetate Screwdriver Set

- Chrome plated shafts and blades for increased corrosion resistance
- Blade tips are designed to ensure tighter tolerance and fit while adding convenience when starting fasteners
- Ergonomic tri-lobe extruded acetate handles provide increased comfort and maximized torque for driving and loosening fasteners
- Easy-to-clean, chemical-resistant acetate handles stand up to all conditions
- Phillips® screwdrivers feature round blades; slotted screwdrivers feature square blades
- Color-coded handles help to quickly identify driver type
- Stamped markings on the handle denote the size of driver to help you quickly identify the needed tool



Cat. No.	Included Storage	Product Weight
CPS6PCSET	None	1.212 lb

Cat. No.	Description	Cat. No.	Description
CP13	#1 x 3" Phillips® Acetate Screwdriver	CS184	1/8" x 4" Slotted Acetate Screwdriver
CP24N	#2 x 4" Phillips® Acetate Screwdriver	CS3166	3/16" x 6" Slotted Acetate Screwdriver
CP26	#2 x 6" Phillips® Acetate Screwdriver	CS144	1/4" x 4" Slotted Acetate Screwdriver

4 Pc. Phillips® Acetate Screwdriver Set

- Chrome plated shafts and blades for increased corrosion resistance
- Blade tips are designed to ensure tighter tolerance and fit while adding convenience when starting fasteners
- Ergonomic tri-lobe extruded acetate handles provide increased comfort and maximized torque for driving and loosening fasteners
- Easy-to-clean, chemical-resistant acetate handles stand up to all conditions
- Phillips® screwdrivers feature round blades
- Color-coded handles help to quickly identify driver type
- Stamped markings on the handle denote the size of driver to help you quickly identify the needed tool



Cat. No.	Included Storage	Product Weight
CP4PCSET	None	0.605 lb

Cat. No.	Description	Cat. No.	Description
CP0212	#0 x 2-1/2" Phillips® Acetate Screwdriver	CP24N	#2 x 4" Phillips® Acetate Screwdriver
CP13	#1 x 3" Phillips® Acetate Screwdriver	CP1112	#1 x 1-1/2" Phillips® Acetate Stubby Screwdriver

4 Pc. Slotted Acetate Screwdriver Set

- Chrome plated shafts and blades for increased corrosion resistance
- Blade tips are designed to ensure tighter tolerance and fit while adding convenience when starting fasteners
- Ergonomic tri-lobe extruded acetate handles provide increased comfort and maximized torque for driving and loosening fasteners
- Easy-to-clean, chemical-resistant acetate handles stand up to all conditions
- Slotted screwdrivers feature square blades
- Color-coded handles help to quickly identify driver type
- Stamped markings on the handle denote the size of driver to help you quickly identify the needed tool



Cat. No.	Included Storage	Product Weight
CS4PCS	None	0.605 lb

Cat. No.	Description	Cat. No.	Description
CS184	1/8" x 4" Slotted Acetate Screwdriver	CS3164	3/16" x 4" Slotted Acetate Screwdriver
CS316112	3/16" x 1-1/2" Slotted Acetate Stubby Screwdriver	CS144	1/4" x 4" Slotted Acetate Screwdriver

4 Pc. Torx® Acetate Screwdriver Set

- Chrome plated shafts and blades for increased corrosion resistance
- Blade tips are designed to ensure tighter tolerance and fit while adding convenience when starting fasteners
- Ergonomic tri-lobe extruded acetate handles provide increased comfort and maximized torque for driving and loosening fasteners
- Easy-to-clean, chemical-resistant acetate handles stand up to all conditions
- Torx® screwdrivers feature round blades
- Color-coded handles help to quickly identify driver type
- Stamped markings on the handle denote the size of driver to help you quickly identify the needed tool



Cat. No.	Included Storage	Product Weight
CT4PCSET	None	0.745 lb

Cat. No.	Description	Cat. No.	Description
CT153	T15 x 3" Torx® Acetate Screwdriver	CT254	T25 x 4" Torx® Acetate Screwdriver
CT203	T20 x 3" Torx® Acetate Screwdriver	CT304	T30 x 4" Torx® Acetate Screwdriver

Multi-Bit Acetate Screwdriver

- 6-in-1 multi-bit screwdriver set
- Multi-bit feature allows for varying applications with a single handle driver
- Ergonomic tri-lobe extruded acetate handles provide increased comfort and maximized torque for driving and loosening fasteners
- Easy-to-clean, chemical-resistant acetate handles stand up to all conditions
- Chrome plated shafts and blades for increased corrosion resistance



Cat. No.	Included Storage	Product Weight
CS61N	None	0.450 lb

Cat. No.	Description	Cat. No.	Description
-	#1 Phillips® Bit	-	9/32" Slotted Bit
-	#2 Phillips® Bit	-	1/4" Nutdriver Bit
-	3/16" Slotted Bit	-	5/16" Nutdriver Bit

Phillips® Acetate Screwdrivers

- Chrome plated shafts and blades for increased corrosion resistance
- Blade tips are designed to ensure tighter tolerance and fit while adding convenience when starting fasteners
- Ergonomic tri-lobe extruded acetate handles provide increased comfort and maximized torque for driving and loosening fasteners
- Easy-to-clean, chemical-resistant acetate handles stand up to all conditions
- Phillips® screwdrivers feature round blades
- Color-coded handles help to quickly identify driver type
- Stamped markings on the handle denote the size of driver to help you quickly identify the needed tool



Cat. No.	Tip Size	Blade Length	Blade Diameter	Overall Length	Handle Size (Dia. X Length)	Product Weight
CP0212	#0	2.5 in	0.117 in	5.00 in	0.70 in x 2.5 in	0.057 lb
CP1112	#1	1.5 in	0.197 in	3.81 in	1.26 in x 2.3 in	0.110 lb
CP13	#1	3.0 in	0.197 in	6.00 in	0.91 in x 3.0 in	0.100 lb
CP2112	#2	1.5 in	0.235 in	3.81 in	1.26 in x 2.3 in	0.120 lb
CP24N	#2	4.0 in	0.235 in	7.81 in	1.15 in x 3.8 in	0.190 lb
CP26	#2	6.0 in	0.235 in	9.81 in	1.15 in x 3.8 in	0.220 lb
CP28	#2	8.0 in	0.235 in	11.81 in	1.15 in x 3.8 in	0.250 lb
CP36	#3	6.0 in	0.312 in	10.50 in	1.25 in x 3.5 in	0.530 lb
CP48	#4	8.0 in	0.370 in	13.25 in	1.31 in x 5.3 in	0.535 lb

Slotted Acetate Screwdrivers

- Chrome plated shafts and blades for increased corrosion resistance
- Blade tips are designed to ensure tighter tolerance and fit while adding convenience when starting fasteners
- Ergonomic tri-lobe extruded acetate handles provide increased comfort and maximized torque for driving and loosening fasteners
- Easy-to-clean, chemical-resistant acetate handles stand up to all conditions
- Slotted screwdrivers feature square blades
- Color-coded handles help to quickly identify driver type
- Stamped markings on the handle denote the size of driver to help you quickly identify the needed tool



Cat. No.	Tip Size	Tip Thickness	Blade Length	Blade Diameter	Overall Length	Handle Size (Dia. X Length)	Product Weight
CS182	1/8 in	0.020 in	2.0 in	0.117 in	4.63 in	0.68 in x 2.6 in	0.040 lb
CS184	1/8 in	0.020 in	4.0 in	0.117 in	6.63 in	0.68 in x 2.6 in	0.050 lb
CS316112	3/16 in	0.027 in	1.5 in	0.196 in	3.19 in	1.26 in x 2.3 in	0.110 lb
CS3164	3/16 in	0.027 in	4.0 in	0.196 in	7.81 in	1.15 in x 3.8 in	0.165 lb
CS3166	3/16 in	0.027 in	6.0 in	0.196 in	9.81 in	1.15 in x 3.8 in	0.200 lb
CS3169	3/16 in	0.027 in	9.0 in	0.196 in	12.81 in	1.15 in x 3.8 in	0.230 lb
CS14112	1/4 in	0.041 in	1.5 in	0.236 in	3.81 in	1.26 in x 2.3 in	0.120 lb
CS144	1/4 in	0.041 in	4.0 in	0.236 in	4.00 in	1.23 in x 4.5 in	0.270 lb
CS148	1/4 in	0.041 in	8.0 in	0.236 in	12.50 in	1.23 in x 4.5 in	0.330 lb
CS5166	5/16 in	0.046 in	6.0 in	0.312 in	10.50 in	1.23 in x 4.5 in	0.420 lb
CS5168	5/16 in	0.046 in	8.0 in	0.312 in	12.50 in	1.23 in x 4.5 in	0.360 lb
CS388	3/8 in	0.059 in	8.0 in	0.372 in	13.25 in	1.34 in x 5.3 in	0.765 lb

Cabinet Acetate Screwdrivers

- Chrome plated shafts and blades for increased corrosion resistance
- Blade tips are designed to ensure tighter tolerance and fit while adding convenience when starting fasteners
- Ergonomic tri-lobe extruded acetate handles provide increased comfort and maximized torque for driving and loosening fasteners
- Easy-to-clean, chemical-resistant acetate handles stand up to all conditions
- Cabinet tip screwdrivers feature round blades
- Color-coded handles help to quickly identify driver type
- Stamped markings on the handle denote the size of driver to help you quickly identify the needed tool



Cat. No.	Tip Size	Tip Thickness	Blade Length	Blade Diameter	Overall Length	Handle Size (Dia. X Length)	Product Weight
CS316R4	3/16 in	0.027 in	4 in	0.196 in	7.812 in	1.15 in x 3.8 in	0.165 lb
CS316R8	3/16 in	0.027 in	8 in	0.196 in	11.812 in	1.15 in x 3.8 in	0.360 lb

Torx® Acetate Screwdrivers

- Chrome plated shafts and blades for increased corrosion resistance
- Blade tips are designed to ensure tighter tolerance and fit while adding convenience when starting fasteners
- Ergonomic tri-lobe extruded acetate handles provide increased comfort and maximized torque for driving and loosening fasteners
- Easy-to-clean, chemical-resistant acetate handles stand up to all conditions
- Torx® screwdrivers feature round blades
- Color-coded handles help to quickly identify driver type
- Stamped markings on the handle denote the size of driver to help you quickly identify the needed tool



Cat. No.	Tip Size	Blade Length	Blade Diameter	Overall Length	Handle Size (Dia. X Length)	Product Weight
CT63	T6	3.00 in	0.196 in	6.11 in	0.913 in x 3.10 in	0.095 lb
CT103	T10	3.00 in	0.196 in	6.11 in	0.913 in x 3.10 in	0.095 lb
CT153	T15	3.00 in	0.196 in	6.11 in	0.913 in x 3.10 in	0.100 lb
CT203	T20	3.00 in	0.196 in	6.11 in	0.913 in x 3.10 in	0.100 lb
CT254	T25	3.75 in	0.196 in	7.75 in	1.140 in x 3.75 in	0.195 lb
CT274	T27	4.00 in	0.236 in	7.75 in	1.140 in x 3.75 in	0.195 lb
CT304	T30	4.00 in	0.236 in	7.75 in	1.140 in x 3.75 in	0.195 lb

Magnetic Bit Holding Acetate Screwdriver

- Chrome plated shaft for increased corrosion resistance
- Ergonomic tri-lobe extruded acetate handles provide increased comfort and maximized torque for driving and loosening fasteners
- Easy-to-clean, chemical-resistant acetate handle stands up to all conditions
- Magnetic bit holder reduces dropped and lost fasteners



Cat. No.	Blade Length	Blade Diameter	Overall Length	Handle Size(Dia. X Length)	Product Weight
CRW25N	2.8 in	0.38 in	6.5 in	1.05 in x 3.72 in	0.270 lb

8 Pc. Diamond Tip Co-Molded Screwdriver Set

- Black phosphate shafts and blades for increased corrosion resistance
- Diamond coated tips for improved torque and grip when fastening
- Co-molded acetate handle for comfort and durability while fastening
- Color-coded handles help to quickly identify driver type
- Meets ASME specifications for drivers



Cat. No.	Included Storage	Product Weight
CGS8PCSET	None	2.720 lb

Cat. No.	Description	Cat. No.	Description
-	#1 x 3" Phillips® Co-Molded Diamond Tip Screwdriver	-	3/16" x 6" Slotted Co-Molded Diamond Tip Screwdriver
-	#2 x 4" Phillips® Co-Molded Diamond Tip Screwdriver	-	1/4" x 4" Slotted Co-Molded Diamond Tip Screwdriver
-	#2 x 6" Phillips® Co-Molded Diamond Tip Screwdriver	-	1/4" x 6" Slotted Co-Molded Diamond Tip Screwdriver
-	3/16" x 4" Slotted Co-Molded Diamond Tip Screwdriver	-	5/16" x 6" Slotted Co-Molded Diamond Tip Screwdriver

4 Pc Diamond Tip Co-Molded Screwdriver Set

- Black phosphate shafts and blades for increased corrosion resistance
- Diamond coated tips for improved torque and grip when fastening
- Co-molded acetate handle for comfort and durability while fastening
- Color-coded handles help to quickly identify driver type
- Meets ASME specifications for drivers



Cat. No.	Included Storage	Product Weight
CGS4PCSET	None	1.146 lb

Cat. No.	Description	Cat. No.	Description
-	#1 x 3" Phillips® Co-Molded Diamond Tip Screwdriver	-	3/16" x 4" Slotted Co-Molded Diamond Tip Screwdriver
-	#2 x 4" Phillips® Co-Molded Diamond Tip Screwdriver	-	1/4" x 4" Slotted Co-Molded Diamond Tip Screwdriver

6 Pc. Diamond Tip Dual Material Precision Screwdriver Set

- Black phosphate shafts and blades for increased corrosion resistance
- Diamond coated tips for improved torque and grip when fastening
- Dual material handles designed for intricate, detailed work
- Plastic case for convenience and storage
- Meets ASME specifications for mini drivers



Cat. No.	Included Storage	Product Weight
CSDP6SET	Plastic Case	0.440 lb

Cat. No.	Description	Cat. No.	Description
-	#00 Phillips® Dual Material Diamond Tip Screwdriver	-	5/64" Slotted Dual Material Diamond Tip Screwdriver
-	#0 Phillips® Dual Material Diamond Tip Screwdriver	-	3/32" Slotted Dual Material Diamond Tip Screwdriver
-	1/16" Slotted Dual Material Diamond Tip Screwdriver	-	1/8" Slotted Dual Material Diamond Tip Screwdriver

5 Pc. SAE Solid Shaft Acetate Handle Nutdriver Set

- Chrome plated shafts for increased corrosion resistance
- Tips are designed to ensure tighter tolerance and fit
- Ergonomic, tri-lobe extruded acetate handles provide increased comfort and maximized torque for driving and loosening fasteners
- Easy-to-clean, chemical-resistant acetate handles stand up to all conditions
- Color-coded handles help to quickly identify driver size
- Clear markings on handle denote the size of driver to help you quickly identify the needed tool
- Meets or exceeds ASME B107.110-20123



Cat. No.	Included Storage	Product Weight
CND5SAEN	None	1.340 lb

Cat. No.	Description	Cat. No.	Description
CND316	3/16" Solid Shaft Tri-Lobe Acetate Nutdriver 3"	CND38	3/8" Solid Shaft Tri-Lobe Acetate Nutdriver 3"
CND14	1/4" Solid Shaft Tri-Lobe Acetate Nutdriver 3"	CND716	7/16" Solid Shaft Tri-Lobe Acetate Nutdriver 3"
CND516	5/16" Solid Shaft Tri-Lobe Acetate Nutdriver 3"		

5 Pc. Metric Solid Shaft Acetate Handle Nutdriver Set

- Chrome plated shafts for increased corrosion resistance
- Tips are designed to ensure tighter tolerance and fit
- Ergonomic, tri-lobe extruded acetate handles provide increased comfort and maximized torque for driving and loosening fasteners
- Easy-to-clean, chemical-resistant acetate handles stand up to all conditions
- Color-coded handles help to quickly identify driver size
- Clear markings on handle denote the size of driver to help you quickly identify the needed tool
- Meets or exceeds ASME B107.110-20123



Cat. No.	Included Storage	Product Weight
CND5MM	None	1.340 lb

Cat. No.	Description	Cat. No.	Description
CND6M	6mm Solid Shaft Tri-Lobe Acetate Nutdriver 3"	CND9M	9mm Solid Shaft Tri-Lobe Acetate Nutdriver 3"
CND7M	7mm Solid Shaft Tri-Lobe Acetate Nutdriver 3"	CND10M	10mm Solid Shaft Tri-Lobe Acetate Nutdriver 3"
CND8M	8mm Solid Shaft Tri-Lobe Acetate Nutdriver 3"		

SAE Solid Shaft Acetate Handle Nutdrivers

- Chrome plated shafts for increased corrosion resistance
- Tips are designed to ensure tighter tolerance and fit
- Ergonomic, tri-lobe extruded acetate handles provide increased comfort and maximized torque for driving and loosening fasteners
- Easy-to-clean, chemical-resistant acetate handles stand up to all conditions
- Color-coded handles help to quickly identify driver size
- Clear markings on handle denote the size of driver to help you quickly identify the needed tool
- Meets or exceeds ASME B107.110-20123



Cat. No.	Size	Shaft Length	Bolt Clearance	Overall Length	Handle Size (Dia. X Length)	Product Weight
CND316	3/16 in	3 in	0.119 in	6.75 in	1 in x 3.75 in	0.175 lb
CND14	1/4 in	3 in	0.127 in	6.75 in	1 in x 3.75 in	0.205 lb
CND516	5/16 in	3 in	0.166 in	6.75 in	1 in x 3.75 in	0.205 lb
CND1132	11/32 in	3 in	0.214 in	6.75 in	1 in x 3.75 in	0.250 lb
CND38	3/8 in	3 in	0.231 in	6.75 in	1 in x 3.75 in	0.260 lb
CND716	7/16 in	3 in	0.312 in	6.75 in	1 in x 3.75 in	0.315 lb
CND12	1/2 in	3 in	0.378 in	6.75 in	1 in x 3.75 in	0.315 lb

Metric Solid Shaft Acetate Handle Nutdrivers

- Chrome plated shafts for increased corrosion resistance
- Tips are designed to ensure tighter tolerance and fit
- Ergonomic, tri-lobe extruded acetate handles provide increased comfort and maximized torque for driving and loosening fasteners
- Easy-to-clean, chemical-resistant acetate handles stand up to all conditions
- Color-coded handles help to quickly identify driver size
- Clear markings on handle denote the size of driver to help you quickly identify the needed tool
- Meets or exceeds ASME B107.110-20123



mm

Cat. No.	Size	Shaft Length	Bolt Clearance	Overall Length	Handle Size (Dia. X Length)	Product Weight
CND5M	5 mm	3 in	0.141 in	6.75 in	1 in x 3.75 in	0.175 lb
CND6M	6 mm	3 in	0.167 in	6.75 in	1 in x 3.75 in	0.205 lb
CND7M	7 mm	3 in	0.204 in	6.75 in	1 in x 3.75 in	0.250 lb
CND8M	8 mm	3 in	0.206 in	6.75 in	1 in x 3.75 in	0.260 lb
CND9M	9 mm	3 in	0.216 in	6.75 in	1 in x 3.75 in	0.255 lb
CND10M	10 mm	3 in	0.253 in	6.75 in	1 in x 3.75 in	0.315 lb
CND11M	11 mm	3 in	0.322 in	6.75 in	1 in x 3.75 in	0.316 lb

3 Pc. SAE/Metric Hex and Torx® Key Fold-up Set

- Versatile range of common sizes
- Measurement type clearly printed for easy recognition
- Size markings for each key
- High strength alloy steel
- Dual-material comfort grip
- Meets or exceeds ASME B18.3.2M metric hex keys
- Meets or exceeds ASME B18.3 SAE hex keys
- Meets or exceeds Camcar TXF-702 Torx® keys



SAE mm

Cat. No.	Keys	Key Sizes	Length	Handle Length	Key Length	Product Weight
CHK3PC	25	SAE: 5/64 in, 3/32 in, 7/64 in, 1/8 in, 9/64 in, 5/32 in, 3/16 in, 7/32 in, 1/4 in Metric: 1.5mm, 2mm, 2.5mm, 3mm, 4mm, 5mm, 6mm, 8mm Torx®: T9, T10, T15, T20, T25, T27, T30, T40	4.5 in	3.75 in	3 in	1.040 lb

9-Key SAE Hex Fold-up Set

- Versatile range of common sizes
- Measurement type clearly printed for easy recognition
- Size markings for each key
- High strength alloy steel
- Dual-material comfort grip
- Meets or exceeds ASME B18.3-2003



SAE

Cat. No.	Keys	Key Sizes	Length	Handle Length	Key Length	Product Weight
CHKFSAE9	9	5/64 in 3/32 in 7/64 in 1/8 in 9/64 in 5/32 in 3/16 in 7/32 in 1/4 in	4.5 in	3.75 in	3 in	0.330 lb

8-Key Metric Hex Key Fold-up Set

- Versatile range of common sizes
- Measurement type clearly printed for easy recognition
- Size markings for each key
- High strength alloy steel
- Dual-material comfort grip
- Meets or exceeds ASME B18.3.2M



mm

Cat. No.	Keys	Key Sizes	Length	Handle Length	Key Length	Product Weight
CHKFM8	8	1.5mm, 2mm, 2.5mm, 3mm, 4mm, 5mm, 6mm, 8mm	4.5 in	3.75 in	3 in	0.360 lb

8-Key Torx® Key Fold-up Set

- Versatile range of common sizes
- Measurement type clearly printed for easy recognition
- Size markings for each key
- High strength alloy steel
- Dual-material comfort grip
- Meets or exceeds Camcar TXF-702



mm

Cat. No.	Keys	Key Sizes	Length	Handle Length	Key Length	Product Weight
CHKFT8	8	T9, T10, T15, T20, T25, T27, T30, T40	4.5 in	3.75 in	3 in	0.350 lb

13-Key SAE Long Arm Hex Key Set

- Long length for increased access
- Short end for higher torque
- High strength alloy steel for strength and durability
- Black oxide finish resists corrosion
- Meets or exceeds ASME B18.3
- Key caddy organizes and stores hex keys



Cat. No.	Keys	Key Sizes	Length	Product Weight
CHKLASAE13	13	.05, 1/16 in, 5/64 in, 3/32 in, 7/64 in, 1/8 in, 9/64 in, 5/32 in, 3/16 in, 7/32 in, 1/4 in, 5/16 in, 3/8 in	7.5 in	0.990 lb

13-Key SAE Ball End Long Arm Hex Key Set

- Ball end hex keys permit an angle of entry of up to 25° for easier access
- Long length for increased access
- Short end for higher torque
- High strength alloy steel for strength and durability
- Black oxide finish resists corrosion
- Meets or exceeds ASME B18.3
- Key caddy organizes and stores hex keys



Cat. No.	Keys	Key Sizes	Length	Product Weight
CHKLABALL13	13	.05, 1/16 in, 5/64 in, 3/32 in, 7/64 in, 1/8 in, 9/64 in, 5/32 in, 3/16 in, 7/32 in, 1/4 in, 5/16 in, 3/8 in	7.5 in	0.970 lb

Mechanics Hand Tools

Multi-Drive • 1/4" Drive • 3/8" Drive • 1/2" Drive • 3/4" Drive • Impact • Wrenches • Torque Wrenches



180 Pc. 1/4" and 3/8" Drive 6 Point SAE/Metric Professional Tool Set

- Contains a carefully selected assortment of hand tools needed for most industrial, mechanical and consumer applications
- Incredible access from long wrenches with narrow heads, adjustable wrenches and pliers, and a long-beam ratchets with small teardrop heads
- Long nose & diagonal pliers with professional, ergonomic dipped grips wipe clean easily
- Co-molded bit driver & screwdriver handles with ergonomic grip for improved performance
- Shallow and deep SAE/metric 6 point full polish chrome sockets with stamped size markings for easy socket identification
- 6" adjustable wrench with hex jaw design reduces slippage by gripping fasteners tightly
- Manufactured from chrome alloy steel for better strength and longer tool life
- Includes blow mold case for storage and organization
- Meets or exceeds ANSI and ASME specifications



Cat. No.	Included Storage	Product Weight
CTK180	Blow Mold Case	19.620 lb

Cat. No.	Description	Cat. No.	Description
-	1/4" Drive 72 Tooth Quick Release Ratchet	-	1/4" Drive 6 Point Deep SAE Socket 5/32"
-	3/8" Drive 72 Tooth Quick Release Ratchet	-	1/4" Drive 6 Point Deep SAE Socket 3/16"
-	1/4" Drive Extension 3"	-	1/4" Drive 6 Point Deep SAE Socket 7/32"
-	3/8" Drive Extension 3"	-	1/4" Drive 6 Point Deep SAE Socket 1/4"
-	3/8" Drive Extension 6"	-	1/4" Drive 6 Point Deep SAE Socket 9/32"
-	1/4" Drive 1/4" M x 3/8" F Adapter	-	1/4" Drive 6 Point Deep SAE Socket 5/16"
-	1/4" Drive 6 Point Standard SAE Socket 5/32"	-	1/4" Drive 6 Point Deep SAE Socket 11/32"
-	1/4" Drive 6 Point Standard SAE Socket 3/16"	-	1/4" Drive 6 Point Deep SAE Socket 3/8"
-	1/4" Drive 6 Point Standard SAE Socket 7/32"	-	1/4" Drive 6 Point Deep Metric Socket 4mm
-	1/4" Drive 6 Point Standard SAE Socket 1/4"	-	1/4" Drive 6 Point Deep Metric Socket 5mm
-	1/4" Drive 6 Point Standard SAE Socket 9/32"	-	1/4" Drive 6 Point Deep Metric Socket 5.5mm
-	1/4" Drive 6 Point Standard SAE Socket 5/16"	-	1/4" Drive 6 Point Deep Metric Socket 6mm
-	1/4" Drive 6 Point Standard SAE Socket 11/32"	-	1/4" Drive 6 Point Deep Metric Socket 7mm
-	1/4" Drive 6 Point Standard SAE Socket 3/8"	-	1/4" Drive 6 Point Deep Metric Socket 8mm
-	1/4" Drive 6 Point Standard SAE Socket 7/16"	-	1/4" Drive 6 Point Deep Metric Socket 9mm
-	1/4" Drive 6 Point Standard SAE Socket 1/2"	-	1/4" Drive 6 Point Deep Metric Socket 10mm
-	1/4" Drive 6 Point Standard SAE Socket 9/16"	-	3/8" Drive 6 Point Standard SAE Socket 3/16"
-	1/4" Drive 6 Point Standard Metric Socket 4mm	-	3/8" Drive 6 Point Standard SAE Socket 7/32"
-	1/4" Drive 6 Point Standard Metric Socket 5mm	-	3/8" Drive 6 Point Standard SAE Socket 1/4"
-	1/4" Drive 6 Point Standard Metric Socket 5.5mm	-	3/8" Drive 6 Point Standard SAE Socket 9/32"
-	1/4" Drive 6 Point Standard Metric Socket 6mm	-	3/8" Drive 6 Point Standard SAE Socket 5/16"
-	1/4" Drive 6 Point Standard Metric Socket 7mm	-	3/8" Drive 6 Point Standard SAE Socket 11/32"
-	1/4" Drive 6 Point Standard Metric Socket 8mm	-	3/8" Drive 6 Point Standard SAE Socket 3/8"
-	1/4" Drive 6 Point Standard Metric Socket 9mm	-	3/8" Drive 6 Point Standard SAE Socket 7/16"
-	1/4" Drive 6 Point Standard Metric Socket 10mm	-	3/8" Drive 6 Point Standard SAE Socket 1/2"
-	1/4" Drive 6 Point Standard Metric Socket 11mm	-	3/8" Drive 6 Point Standard SAE Socket 9/16"
-	1/4" Drive 6 Point Standard Metric Socket 12mm	-	3/8" Drive 6 Point Standard SAE Socket 5/8"
-	1/4" Drive 6 Point Standard Metric Socket 13mm	-	3/8" Drive 6 Point Standard SAE Socket 11/16"

Cat. No.	Description	Cat. No.	Description
-	3/8" Drive 6 Point Standard SAE Socket 3/4"	-	15mm 12 Point Long Pattern Combination Wrench
-	3/8" Drive 6 Point Standard SAE Socket 7/8"	-	1/29" Hex Key
-	3/8" Drive 6 Point Standard SAE Socket 15/16"	-	1/20" Hex Key
-	3/8" Drive 6 Point Standard SAE Socket 1"	-	1/16" Hex Key
-	3/8" Drive 6 Point Standard Metric Socket 12mm	-	5/64" Hex Key
-	3/8" Drive 6 Point Standard Metric Socket 13mm	-	3/32" Hex Key
-	3/8" Drive 6 Point Standard Metric Socket 14mm	-	7/64" Hex Key
-	3/8" Drive 6 Point Standard Metric Socket 15mm	-	1/8" Hex Key
-	3/8" Drive 6 Point Standard Metric Socket 16mm	-	9/64" Hex Key
-	3/8" Drive 6 Point Standard Metric Socket 17mm	-	5/32" Hex Key
-	3/8" Drive 6 Point Standard Metric Socket 18mm	-	3/16" Hex Key
-	3/8" Drive 6 Point Standard Metric Socket 19mm	-	7/32" Hex Key
-	3/8" Drive 6 Point Standard Metric Socket 20mm	-	1/4" Hex Key
-	3/8" Drive 6 Point Standard Metric Socket 21mm	-	.9mm Hex Key
-	3/8" Drive 6 Point Standard Metric Socket 22mm	-	1.3mm Hex Key
-	3/8" Drive 6 Point Standard Metric Socket 23mm	-	1.5mm Hex Key
-	3/8" Drive 6 Point Standard Metric Socket 24mm	-	2mm Hex Key
-	3/8" Drive 6 Point Deep SAE Socket 3/8"	-	2.5mm Hex Key
-	3/8" Drive 6 Point Deep SAE Socket 7/16"	-	3mm Hex Key
-	3/8" Drive 6 Point Deep SAE Socket 1/2"	-	3.5mm Hex Key
-	3/8" Drive 6 Point Deep SAE Socket 5/8"	-	4mm Hex Key
-	3/8" Drive 6 Point Deep SAE Socket 9/16"	-	4.5mm Hex Key
-	3/8" Drive 6 Point Deep SAE Socket 11/16"	-	5mm Hex Key
-	3/8" Drive 6 Point Deep SAE Socket 3/4"	-	5.5mm Hex Key
-	3/8" Drive 6 Point Deep Metric Socket 12mm	-	6mm Hex Key
-	3/8" Drive 6 Point Deep Metric Socket 13mm	-	6" Diagonal Pliers
-	3/8" Drive 6 Point Deep Metric Socket 14mm	-	6" Long Nose Pliers
-	3/8" Drive 6 Point Deep Metric Socket 15mm	-	6" Adjustable Wrench
-	3/8" Drive 6 Point Deep Metric Socket 16mm	-	#1 x 3" Phillips® Dual Material Screwdriver
-	3/8" Drive 6 Point Deep Metric Socket 17mm	-	#2 x 4" Phillips® Dual Material Screwdriver
-	3/8" Drive 6 Point Deep Metric Socket 18mm	-	1/4" x 4" Slotted Dual Material Screwdriver
-	3/8" Drive 6 Point Deep Metric Socket 19mm	-	3/16" x 3" Slotted Dual Material Screwdriver
-	3/8" Drive 6 Point Spark Plug Socket 5/8"	-	Dual Material Magnetic Bit Driver
-	5/16" 12 Point Long Pattern Combination Wrench	-	1/4" Drive Bit Adapter
-	3/8" 12 Point Long Pattern Combination Wrench	-	#0 Phillips® Bit
-	7/16" 12 Point Long Pattern Combination Wrench	-	#1 Phillips® Bit
-	1/2" 12 Point Long Pattern Combination Wrench	-	#2 Phillips® Bit
-	9/16" 12 Point Long Pattern Combination Wrench	-	#3 Phillips® Bit
-	5/8" 12 Point Long Pattern Combination Wrench	-	3/32" Slotted Bit
-	8mm 12 Point Long Pattern Combination Wrench	-	1/8" Slotted Bit
-	10mm 12 Point Long Pattern Combination Wrench	-	5/32" Slotted Bit
-	12mm 12 Point Long Pattern Combination Wrench	-	3/16" Slotted Bit
-	13mm 12 Point Long Pattern Combination Wrench	-	7/32" Slotted Bit
-	14mm 12 Point Long Pattern Combination Wrench	-	1/4" Slotted Bit

■ Continued on next page

MULTI-DRIVE

MULTI-DRIVE

180 Pc. 1/4" and 3/8" Drive 6 Point SAE/Metric Professional Tool Set

Continued from previous page

Cat. No.	Description	Cat. No.	Description
-	3mm Slotted Bit	-	7mm Hex Bit
-	4mm Slotted Bit	-	S0 Square Bit
-	5mm Slotted Bit	-	S1 Square Bit
-	6mm Slotted Bit	-	S2 Square Bit
-	7mm Slotted Bit	-	S3 Square Bit
-	#0 Pozidriv® Bit	-	T5 Torx® Bit
-	#1 Pozidriv® Bit	-	T7 Torx® Bit
-	#2 Pozidriv® Bit	-	T8 Torx® Bit
-	#3 Pozidriv® Bit	-	T10 Torx® Bit
-	1/8" Hex Bit	-	T15 Torx® Bit
-	5/32" Hex Bit	-	T25 Torx® Bit
-	3/16" Hex Bit	-	T27 Torx® Bit
-	7/32" Hex Bit	-	T30 Torx® Bit
-	5/16" Hex Bit	-	T40 Torx® Bit
-	3mm Hex Bit	-	T8 Tamper-proof Torx® Bit
-	4mm Hex Bit	-	T10 Tamper-proof Torx® Bit
-	5mm Hex Bit	-	T15 Tamper-proof Torx® Bit
-	6mm Hex Bit	-	T20 Tamper-proof Torx® Bit

MULTI-DRIVE

MULTI-DRIVE

150 Pc. 1/4" and 3/8" Drive 6 Point SAE/Metric Professional Tool Set

- Contains a carefully selected assortment of hand tools needed for most industrial, mechanical and consumer applications
- Incredible access from combination wrenches with narrow heads, adjustable wrenches and pliers, and low profile head quick release ratchets
- Long nose & diagonal pliers with professional, ergonomic dipped grips wipe clean easily
- Co-molded bit driver & screwdriver handles with ergonomic grip for improved performance
- Shallow and deep SAE/metric 6 point full polish chrome sockets with stamped size markings for easy socket identification
- 6" adjustable wrench with hex jaw design reduces slippage by gripping fasteners tightly
- Manufactured from chrome alloy steel for better strength and longer tool life
- Includes blow mold case for storage and organization
- Meets or exceeds ANSI and ASME specifications



Cat. No.	Included Storage	Product Weight
CTK150	Blow Mold Case	16.755 lb



Cat. No.	Description	Cat. No.	Description
-	1/4" Drive 72 Tooth Quick Release Ratchet	-	3/8" Drive 72 Tooth Quick Release Ratchet

Cat. No.	Description	Cat. No.	Description
-	1/4" Drive Extension 3"	-	3/8" Drive 6 Point Standard Metric Socket 15mm
-	3/8" Drive Extension 3"	-	3/8" Drive 6 Point Standard Metric Socket 16mm
-	3/8" Drive Extension 6"	-	3/8" Drive 6 Point Standard Metric Socket 17mm
-	1/4" Drive 6 Point Standard SAE Socket 5/32"	-	3/8" Drive 6 Point Standard Metric Socket 18mm
-	1/4" Drive 6 Point Standard SAE Socket 3/16"	-	3/8" Drive 6 Point Standard Metric Socket 19mm
-	1/4" Drive 6 Point Standard SAE Socket 7/32"	-	3/8" Drive 6 Point Standard Metric Socket 20mm
-	1/4" Drive 6 Point Standard SAE Socket 1/4"	-	3/8" Drive 6 Point Standard Metric Socket 21mm
-	1/4" Drive 6 Point Standard SAE Socket 9/32"	-	3/8" Drive 6 Point Standard Metric Socket 22mm
-	1/4" Drive 6 Point Standard SAE Socket 5/16"	-	3/8" Drive 6 Point Standard Metric Socket 23mm
-	1/4" Drive 6 Point Standard SAE Socket 11/32"	-	3/8" Drive 6 Point Standard Metric Socket 24mm
-	1/4" Drive 6 Point Standard SAE Socket 3/8"	-	3/8" Drive 6 Point Spark Plug Socket 5/8"
-	1/4" Drive 6 Point Standard SAE Socket 7/16"	-	5/16" 12 Point Long Pattern Combination Wrench
-	1/4" Drive 6 Point Standard SAE Socket 1/2"	-	3/8" 12 Point Long Pattern Combination Wrench
-	1/4" Drive 6 Point Standard SAE Socket 9/16"	-	7/16" 12 Point Long Pattern Combination Wrench
-	1/4" Drive 6 Point Standard Metric Socket 4mm	-	1/2" 12 Point Long Pattern Combination Wrench
-	1/4" Drive 6 Point Standard Metric Socket 5mm	-	9/16" 12 Point Long Pattern Combination Wrench
-	1/4" Drive 6 Point Standard Metric Socket 5.5mm	-	5/8" 12 Point Long Pattern Combination Wrench
-	1/4" Drive 6 Point Standard Metric Socket 6mm	-	8mm 12 Point Long Pattern Combination Wrench
-	1/4" Drive 6 Point Standard Metric Socket 7mm	-	10mm 12 Point Long Pattern Combination Wrench
-	1/4" Drive 6 Point Standard Metric Socket 8mm	-	12mm 12 Point Long Pattern Combination Wrench
-	1/4" Drive 6 Point Standard Metric Socket 9mm	-	13mm 12 Point Long Pattern Combination Wrench
-	1/4" Drive 6 Point Standard Metric Socket 10mm	-	14mm 12 Point Long Pattern Combination Wrench
-	1/4" Drive 6 Point Standard Metric Socket 11mm	-	15mm 12 Point Long Pattern Combination Wrench
-	1/4" Drive 6 Point Standard Metric Socket 12mm	-	1/29" Hex Key
-	1/4" Drive 6 Point Standard Metric Socket 13mm	-	1/20" Hex Key
-	3/8" Drive 6 Point Standard SAE Socket 3/16"	-	1/16" Hex Key
-	3/8" Drive 6 Point Standard SAE Socket 7/32"	-	5/64" Hex Key
-	3/8" Drive 6 Point Standard SAE Socket 1/4"	-	3/32" Hex Key
-	3/8" Drive 6 Point Standard SAE Socket 9/32"	-	7/64" Hex Key
-	3/8" Drive 6 Point Standard SAE Socket 5/16"	-	1/8" Hex Key
-	3/8" Drive 6 Point Standard SAE Socket 11/32"	-	9/64" Hex Key
-	3/8" Drive 6 Point Standard SAE Socket 3/8"	-	5/32" Hex Key
-	3/8" Drive 6 Point Standard SAE Socket 7/16"	-	3/16" Hex Key
-	3/8" Drive 6 Point Standard SAE Socket 1/2"	-	7/32" Hex Key
-	3/8" Drive 6 Point Standard SAE Socket 9/16"	-	1/4" Hex Key
-	3/8" Drive 6 Point Standard SAE Socket 5/8"	-	.9mm Hex Key
-	3/8" Drive 6 Point Standard SAE Socket 11/16"	-	1.3mm Hex Key
-	3/8" Drive 6 Point Standard SAE Socket 3/4"	-	1.5mm Hex Key
-	3/8" Drive 6 Point Standard SAE Socket 7/8"	-	2mm Hex Key
-	3/8" Drive 6 Point Standard SAE Socket 15/16"	-	2.5mm Hex Key
-	3/8" Drive 6 Point Standard SAE Socket 1"	-	3mm Hex Key
-	3/8" Drive 6 Point Standard Metric Socket 12mm	-	3.5mm Hex Key
-	3/8" Drive 6 Point Standard Metric Socket 13mm	-	4mm Hex Key
-	3/8" Drive 6 Point Standard Metric Socket 14mm	-	4.5mm Hex Key

Continued on next page

150 Pc. 1/4" and 3/8" Drive 6 Point SAE/Metric Professional Tool Set

Continued from previous page

Cat. No.	Description	Cat. No.	Description
-	5mm Hex Key	-	7/32" Hex Bit
-	5.5mm Hex Key	-	3mm Hex Bit
-	6mm Hex Key	-	4mm Hex Bit
-	6" Diagonal Pliers	-	5mm Hex Bit
-	6" Long Nose Pliers	-	6mm Hex Bit
-	6" Adjustable Wrench	-	7mm Hex Bit
-	#2 x 4" Phillips® Dual Material Screwdriver	-	S1 Square Bit
-	1/4" x 4" Slotted Dual Material Screwdriver	-	S2 Square Bit
-	Dual Material Magnetic Bit Driver	-	S3 Square Bit
-	1/4" Drive Bit Adapter	-	T5 Torx® Bit
-	#1 Phillips® Bit	-	T7 Torx® Bit
-	#2 Phillips® Bit	-	T8 Torx® Bit
-	#3 Phillips® Bit	-	T10 Torx® Bit
-	3/32" Slotted Bit	-	T15 Torx® Bit
-	1/8" Slotted Bit	-	T25 Torx® Bit
-	5/32" Slotted Bit	-	T27 Torx® Bit
-	3/16" Slotted Bit	-	T30 Torx® Bit
-	7/32" Slotted Bit	-	T40 Torx® Bit
-	1/4" Slotted Bit	-	5/32" Nutdriver Bit
-	3mm Slotted Bit	-	3/16" Nutdriver Bit
-	4mm Slotted Bit	-	7/32" Nutdriver Bit
-	5mm Slotted Bit	-	1/4" Nutdriver Bit
-	6mm Slotted Bit	-	9/32" Nutdriver Bit
-	7mm Slotted Bit	-	5/16" Nutdriver Bit
-	#0 Pozidriv® Bit	-	4mm Nutdriver Bit
-	#1 Pozidriv® Bit	-	5mm Nutdriver Bit
-	#2 Pozidriv® Bit	-	6mm Nutdriver Bit
-	#3 Pozidriv® Bit	-	7mm Nutdriver Bit
-	5/32" Hex Bit	-	8mm Nutdriver Bit
-	3/16" Hex Bit	-	10mm Nutdriver Bit

142 Pc. 1/4", 3/8", and 1/2" Drive 6 and 12 Point SAE/Metric Mechanics Tool Set

- Contains a carefully selected assortment of hand tools needed for most industrial, mechanical and consumer applications
- Heavy-duty 1/4", 3/8" and 1/2" drive 60-tooth ratchets feature a compact teardrop shaped head for getting into limited access spaces and long, balanced handles for better leverage and control
- Long pattern combination wrenches for improved access and torque
- Acetate magnetic bit driver for improved impact, UV, and solvent resistance
- Innovative new hex key caddy makes accessing the size you need quick and easy
- Manufactured from chrome alloy steel for better strength and longer tool life
- Includes blow mold case for storage and organization
- Meets or exceeds ANSI and ASME specifications



Cat. No.	Included Storage	Product Weight
CTK142	Blow Mold Case	17.335 lb

Cat. No.	Description	Cat. No.	Description
CRWON	1/4" Drive 60 Tooth Quick Release Teardrop Ratchet 6"	CDDS4N	1/4" Drive 6 Point Deep SAE Socket 9/32"
CRW6N	3/8" Drive 60 Tooth Quick Release Teardrop Ratchet 9"	CDDS5N	1/4" Drive 6 Point Deep SAE Socket 5/16"
CRW12N	1/2" Drive 60 Tooth Quick Release Teardrop Ratchet 10-1/2"	CDDS6N	1/4" Drive 6 Point Deep SAE Socket 11/32"
-	1/4" Drive Extension 3"	CDDS7N	1/4" Drive 6 Point Deep SAE Socket 3/8"
CDTA8N	3/8" Drive Extension 3"	CDDS8N	1/4" Drive 6 Point Deep SAE Socket 7/16"
CDTA12N	1/2" Drive Extension 5"	CDDS13N	1/4" Drive 6 Point Deep Metric Socket 6mm
CDS0N	1/4" Drive 6 Point Standard SAE Socket 5/32"	CDDS14N	1/4" Drive 6 Point Deep Metric Socket 7mm
CDS1N	1/4" Drive 6 Point Standard SAE Socket 3/16"	CDDS15N	1/4" Drive 6 Point Deep Metric Socket 8mm
CDS2N	1/4" Drive 6 Point Standard SAE Socket 7/32"	CDDS16N	1/4" Drive 6 Point Deep Metric Socket 9mm
CDS3N	1/4" Drive 6 Point Standard SAE Socket 1/4"	CDDS17N	1/4" Drive 6 Point Deep Metric Socket 10mm
CDS4N	1/4" Drive 6 Point Standard SAE Socket 9/32"	CDDS19N	1/4" Drive 6 Point Deep Metric Socket 12mm
CDS5N	1/4" Drive 6 Point Standard SAE Socket 5/16"	-	3/8" Drive 12 Point Standard SAE Socket 3/16"
CDS6N	1/4" Drive 6 Point Standard SAE Socket 11/32"	CDS23N	3/8" Drive 12 Point Standard SAE Socket 1/4"
CDS7N	1/4" Drive 6 Point Standard SAE Socket 3/8"	CDS24N	3/8" Drive 12 Point Standard SAE Socket 5/16"
CDS8N	1/4" Drive 6 Point Standard SAE Socket 7/16"	CDS25N	3/8" Drive 12 Point Standard SAE Socket 3/8"
CDS9N	1/4" Drive 6 Point Standard SAE Socket 1/2"	CDS26N	3/8" Drive 12 Point Standard SAE Socket 7/16"
-	1/4" Drive 6 Point Standard SAE Socket 9/16"	CDS27N	3/8" Drive 12 Point Standard SAE Socket 1/2"
CDS11N	1/4" Drive 6 Point Standard Metric Socket 4mm	CDS28N	3/8" Drive 12 Point Standard SAE Socket 9/16"
CDS12N	1/4" Drive 6 Point Standard Metric Socket 5mm	CDS29N	3/8" Drive 12 Point Standard SAE Socket 5/8"
-	1/4" Drive 6 Point Standard Metric Socket 5.5mm	CDS31N	3/8" Drive 12 Point Standard SAE Socket 3/4"
CDS13N	1/4" Drive 6 Point Standard Metric Socket 6mm	CDS32N	3/8" Drive 12 Point Standard SAE Socket 13/16"
CDS14N	1/4" Drive 6 Point Standard Metric Socket 7mm	-	3/8" Drive 12 Point Standard Metric Socket 6mm
CDS15N	1/4" Drive 6 Point Standard Metric Socket 8mm	CDS37N	3/8" Drive 12 Point Standard Metric Socket 7mm
CDS16N	1/4" Drive 6 Point Standard Metric Socket 9mm	CDS38N	3/8" Drive 12 Point Standard Metric Socket 8mm
CDS17N	1/4" Drive 6 Point Standard Metric Socket 10mm	CDS39N	3/8" Drive 12 Point Standard Metric Socket 9mm
CDS18N	1/4" Drive 6 Point Standard Metric Socket 11mm	CDS40N	3/8" Drive 12 Point Standard Metric Socket 10mm
CDS19N	1/4" Drive 6 Point Standard Metric Socket 12mm	CDS41N	3/8" Drive 12 Point Standard Metric Socket 11mm
CDS20N	1/4" Drive 6 Point Standard Metric Socket 13mm	CDS42N	3/8" Drive 12 Point Standard Metric Socket 12mm
-	1/4" Drive 6 Point Standard Metric Socket 14mm	CDS43N	3/8" Drive 12 Point Standard Metric Socket 13mm
CDDS3N	1/4" Drive 6 Point Deep SAE Socket 1/4"		

Continued on next page

MULTI-DRIVE

MULTI-DRIVE

142 Pc. 1/4", 3/8", and 1/2" Drive 6 and 12 Point SAE/Metric Mechanics Tool Set

Continued from previous page

Cat. No.	Description	Cat. No.	Description
CDS44N	3/8" Drive 12 Point Standard Metric Socket 14mm	CDS53N	1/2" Drive 12 Point Standard SAE Socket 7/16"
CDS45N	3/8" Drive 12 Point Standard Metric Socket 15mm	CDS54N	1/2" Drive 12 Point Standard SAE Socket 1/2"
CDS46N	3/8" Drive 12 Point Standard Metric Socket 16mm	CDS55N	1/2" Drive 12 Point Standard SAE Socket 9/16"
CDS47N	3/8" Drive 12 Point Standard Metric Socket 17mm	CDS56N	1/2" Drive 12 Point Standard SAE Socket 5/8"
CDS48N	3/8" Drive 12 Point Standard Metric Socket 18mm	CDS57N	1/2" Drive 12 Point Standard SAE Socket 11/16"
CDS49N	3/8" Drive 12 Point Standard Metric Socket 19mm	CDS58N	1/2" Drive 12 Point Standard SAE Socket 3/4"
CDDS26N	3/8" Drive 6 Point Deep SAE Socket 7/16"	CDS59N	1/2" Drive 12 Point Standard SAE Socket 13/16"
CDDS27N	3/8" Drive 6 Point Deep SAE Socket 1/2"	CDS60N	1/2" Drive 12 Point Standard SAE Socket 7/8"
CDDS28N	3/8" Drive 6 Point Deep SAE Socket 9/16"	CCW3	3/8" 12 Point Combination Wrench
CDDS29N	3/8" Drive 6 Point Deep SAE Socket 5/8"	CCW4	7/16" 12 Point Combination Wrench
CDDS30N	3/8" Drive 6 Point Deep SAE Socket 11/16"	CCW5	1/2" 12 Point Combination Wrench
CDDS31N	3/8" Drive 6 Point Deep SAE Socket 3/4"	CCW21	10mm 12 Point Combination Wrench
CDDS39N	3/8" Drive 6 Point Deep Metric Socket 9mm	CCW23	12mm 12 Point Combination Wrench
CDDS40N	3/8" Drive 6 Point Deep Metric Socket 10mm	CCW24	13mm 12 Point Combination Wrench
CDDS41N	3/8" Drive 6 Point Deep Metric Socket 11mm	CRW25N	1/4" Drive Magnetic Bit Holding Screwdriver Handle
CDDS42N	3/8" Drive 6 Point Deep Metric Socket 12mm	-	12 Pc Short Arm SAE Hex Key Set with Caddie
CDDS43N	3/8" Drive 6 Point Deep Metric Socket 13mm	-	12 Pc Short Arm Metric Hex Key Set with Caddie
CDDS44N	3/8" Drive 6 Point Deep Metric Socket 14mm	-	1/4" Drive Bit Adapter
CDDS45N	3/8" Drive 6 Point Deep Metric Socket 15mm	-	10 Assorted Insert Bits in Holder
CDDS46N	3/8" Drive 6 Point Deep Metric Socket 16mm	-	7 SAE Nut Setter Bits
CDDS47N	3/8" Drive 6 Point Deep Metric Socket 17mm	-	5 Metric Nut Setter Bits

121 Pc. 1/4" and 3/8" Drive 6 and 12 Point SAE/Metric Mechanics Tool Set

- Contains a carefully selected assortment of hand tools needed for most industrial, mechanical and consumer applications
- Heavy-duty 1/4" and 3/8" drive 60-tooth ratchets feature a compact teardrop shaped head for getting into limited access spaces and long, balanced handles for better leverage and control
- Acetate magnetic bit driver for improved impact, UV, and solvent resistance
- Innovative new hex key caddy makes accessing the size you need quick and easy
- Manufactured from chrome alloy steel for better strength and longer tool life
- Includes blow mold case for storage and organization
- Meets or exceeds ANSI and ASME specifications



Cat. No.	Included Storage	Product Weight
CTK121	Blow Mold Case	12.050 lb

Cat. No.	Description	Cat. No.	Description
CRW0N	1/4" Drive 60 Tooth Quick Release Teardrop Ratchet 6"	CRW6N	3/8" Drive 60 Tooth Quick Release Teardrop Ratchet 9"

Cat. No.	Description	Cat. No.	Description
CDTA8N	3/8" Drive Extension 3"	CDS25N	3/8" Drive 12 Point Standard SAE Socket 3/8"
CDS0N	1/4" Drive 6 Point Standard SAE Socket 5/32"	CDS26N	3/8" Drive 12 Point Standard SAE Socket 7/16"
CDS1N	1/4" Drive 6 Point Standard SAE Socket 3/16"	CDS27N	3/8" Drive 12 Point Standard SAE Socket 1/2"
CDS2N	1/4" Drive 6 Point Standard SAE Socket 7/32"	CDS28N	3/8" Drive 12 Point Standard SAE Socket 9/16"
CDS3N	1/4" Drive 6 Point Standard SAE Socket 1/4"	CDS29N	3/8" Drive 12 Point Standard SAE Socket 5/8"
CDS4N	1/4" Drive 6 Point Standard SAE Socket 9/32"	CDS31N	3/8" Drive 12 Point Standard SAE Socket 3/4"
CDS5N	1/4" Drive 6 Point Standard SAE Socket 5/16"	-	3/8" Drive 12 Point Standard Metric Socket 6mm
CDS6N	1/4" Drive 6 Point Standard SAE Socket 11/32"	CDS37N	3/8" Drive 12 Point Standard Metric Socket 7mm
CDS7N	1/4" Drive 6 Point Standard SAE Socket 3/8"	CDS38N	3/8" Drive 12 Point Standard Metric Socket 8mm
CDS8N	1/4" Drive 6 Point Standard SAE Socket 7/16"	CDS39N	3/8" Drive 12 Point Standard Metric Socket 9mm
CDS9N	1/4" Drive 6 Point Standard SAE Socket 1/2"	CDS40N	3/8" Drive 12 Point Standard Metric Socket 10mm
-	1/4" Drive 6 Point Standard SAE Socket 9/16"	CDS41N	3/8" Drive 12 Point Standard Metric Socket 11mm
CDS11N	1/4" Drive 6 Point Standard Metric Socket 4mm	CDS42N	3/8" Drive 12 Point Standard Metric Socket 12mm
CDS12N	1/4" Drive 6 Point Standard Metric Socket 5mm	CDS43N	3/8" Drive 12 Point Standard Metric Socket 13mm
-	1/4" Drive 6 Point Standard Metric Socket 5.5mm	CDS44N	3/8" Drive 12 Point Standard Metric Socket 14mm
CDS13N	1/4" Drive 6 Point Standard Metric Socket 6mm	CDS45N	3/8" Drive 12 Point Standard Metric Socket 15mm
CDS14N	1/4" Drive 6 Point Standard Metric Socket 7mm	CDS46N	3/8" Drive 12 Point Standard Metric Socket 16mm
CDS15N	1/4" Drive 6 Point Standard Metric Socket 8mm	CDS47N	3/8" Drive 12 Point Standard Metric Socket 17mm
CDS16N	1/4" Drive 6 Point Standard Metric Socket 9mm	CDS48N	3/8" Drive 12 Point Standard Metric Socket 18mm
CDS17N	1/4" Drive 6 Point Standard Metric Socket 10mm	CDS49N	3/8" Drive 12 Point Standard Metric Socket 19mm
CDS18N	1/4" Drive 6 Point Standard Metric Socket 11mm	CDDS26N	3/8" Drive 6 Point Deep SAE Socket 7/16"
CDS19N	1/4" Drive 6 Point Standard Metric Socket 12mm	CDDS27N	3/8" Drive 6 Point Deep SAE Socket 1/2"
CDS20N	1/4" Drive 6 Point Standard Metric Socket 13mm	CDDS28N	3/8" Drive 6 Point Deep SAE Socket 9/16"
CDDS3N	1/4" Drive 6 Point Deep SAE Socket 1/4"	CDDS29N	3/8" Drive 6 Point Deep SAE Socket 5/8"
CDDS4N	1/4" Drive 6 Point Deep SAE Socket 9/32"	CDDS30N	3/8" Drive 6 Point Deep SAE Socket 11/16"
CDDS5N	1/4" Drive 6 Point Deep SAE Socket 5/16"	CDDS31N	3/8" Drive 6 Point Deep SAE Socket 3/4"
CDDS6N	1/4" Drive 6 Point Deep SAE Socket 11/32"	CDDS39N	3/8" Drive 6 Point Deep Metric Socket 9mm
CDDS7N	1/4" Drive 6 Point Deep SAE Socket 3/8"	CDDS40N	3/8" Drive 6 Point Deep Metric Socket 10mm
CDDS8N	1/4" Drive 6 Point Deep SAE Socket 7/16"	CDDS41N	3/8" Drive 6 Point Deep Metric Socket 11mm
CDDS13N	1/4" Drive 6 Point Deep Metric Socket 6mm	CDDS42N	3/8" Drive 6 Point Deep Metric Socket 12mm
CDDS14N	1/4" Drive 6 Point Deep Metric Socket 7mm	CDDS43N	3/8" Drive 6 Point Deep Metric Socket 13mm
CDDS15N	1/4" Drive 6 Point Deep Metric Socket 8mm	CDDS44N	3/8" Drive 6 Point Deep Metric Socket 14mm
CDDS16N	1/4" Drive 6 Point Deep Metric Socket 9mm	CRW25N	1/4" Drive Magnetic Bit Holding Screwdriver Handle
CDDS17N	1/4" Drive 6 Point Deep Metric Socket 10mm	-	1/4" Drive Bit Adapter
CDDS18N	1/4" Drive 6 Point Deep Metric Socket 11mm	-	12 Pc Short Arm SAE Hex Key Set with Caddie
CDDS19N	1/4" Drive 6 Point Deep Metric Socket 12mm	-	12 Pc Short Arm Metric Hex Key Set with Caddie
-	1/4" Drive 6 Point Deep Metric Socket 14mm	-	9 Assorted Insert Bits in Holder
-	3/8" Drive 12 Point Standard SAE Socket 3/16"	-	7 SAE Nut Setter Bits
CDS23N	3/8" Drive 12 Point Standard SAE Socket 1/4"	-	5 Metric Nut Setter Bits
CDS24N	3/8" Drive 12 Point Standard SAE Socket 5/16"		

84 Pc. 1/4" and 3/8" Drive 6 and 12 Point SAE/Metric Mechanics Tool Set

- Contains a carefully selected assortment of hand tools needed for most industrial, mechanical and consumer applications
- Acetate magnetic bit driver for improved impact, UV, and solvent resistance
- Manufactured from chrome alloy steel for better strength and longer tool life
- Includes blow mold case for storage and organization
- Meets or exceeds ANSI and ASME specifications



Cat. No.	Included Storage	Product Weight
CTK84CMPN	Blow Mold Case	6.830 lb

Cat. No.	Description	Cat. No.	Description
CRW0N	1/4" Drive 60 Tooth Quick Release Teardrop Ratchet 6"	CDDS15N	1/4" Drive 6 Point Deep Metric Socket 8mm
CRW6N	3/8" Drive 60 Tooth Quick Release Teardrop Ratchet 9"	CDDS17N	1/4" Drive 6 Point Deep Metric Socket 10mm
CDTA8N	3/8" Drive Extension 3"	CDDS18N	1/4" Drive 6 Point Deep Metric Socket 11mm
CDTA1N	3/8" Drive 3/8" F x 1/4" M Adapter	CDDS19N	1/4" Drive 6 Point Deep Metric Socket 12mm
CDS0N	1/4" Drive 6 Point Standard SAE Socket 5/32"	CDS26N	3/8" Drive 12 Point Standard SAE Socket 7/16"
CDS1N	1/4" Drive 6 Point Standard SAE Socket 3/16"	CDS27N	3/8" Drive 12 Point Standard SAE Socket 1/2"
CDS2N	1/4" Drive 6 Point Standard SAE Socket 7/32"	CDS28N	3/8" Drive 12 Point Standard SAE Socket 9/16"
CDS3N	1/4" Drive 6 Point Standard SAE Socket 1/4"	CDS29N	3/8" Drive 12 Point Standard SAE Socket 5/8"
CDS4N	1/4" Drive 6 Point Standard SAE Socket 9/32"	CDS30N	3/8" Drive 12 Point Standard SAE Socket 11/16"
CDS5N	1/4" Drive 6 Point Standard SAE Socket 5/16"	CDS31N	3/8" Drive 12 Point Standard SAE Socket 3/4"
CDS6N	1/4" Drive 6 Point Standard SAE Socket 11/32"	CDS32N	3/8" Drive 12 Point Standard SAE Socket 13/16"
CDS7N	1/4" Drive 6 Point Standard SAE Socket 3/8"	CDS33N	3/8" Drive 12 Point Standard SAE Socket 7/8"
CDS11N	1/4" Drive 6 Point Standard Metric Socket 4mm	CDS42N	3/8" Drive 12 Point Standard Metric Socket 12mm
CDS12N	1/4" Drive 6 Point Standard Metric Socket 5mm	CDS43N	3/8" Drive 12 Point Standard Metric Socket 13mm
CDS13N	1/4" Drive 6 Point Standard Metric Socket 6mm	CDS44N	3/8" Drive 12 Point Standard Metric Socket 14mm
CDS14N	1/4" Drive 6 Point Standard Metric Socket 7mm	CDS45N	3/8" Drive 12 Point Standard Metric Socket 15mm
CDS15N	1/4" Drive 6 Point Standard Metric Socket 8mm	CDS46N	3/8" Drive 12 Point Standard Metric Socket 16mm
CDS16N	1/4" Drive 6 Point Standard Metric Socket 9mm	CDS47N	3/8" Drive 12 Point Standard Metric Socket 17mm
CDS17N	1/4" Drive 6 Point Standard Metric Socket 10mm	CDS48N	3/8" Drive 12 Point Standard Metric Socket 18mm
CDS18N	1/4" Drive 6 Point Standard Metric Socket 11mm	CDS49N	3/8" Drive 12 Point Standard Metric Socket 19mm
CDDS1N	1/4" Drive 6 Point Deep SAE Socket 3/16"	CRW25N	1/4" Drive Magnetic Bit Holding Screwdriver Handle
CDDS3N	1/4" Drive 6 Point Deep SAE Socket 1/4"	-	15 Assorted Insert Bits in Holder
CDDS5N	1/4" Drive 6 Point Deep SAE Socket 5/16"	-	6 SAE Nut Setter Bits
CDDS7N	1/4" Drive 6 Point Deep SAE Socket 3/8"	-	8 Short Arm SAE Hex Keys with Caddie
CDDS8N	1/4" Drive 6 Point Deep SAE Socket 7/16"	-	8 Short Arm Metric Hex Keys with Caddie
CDDS13N	1/4" Drive 6 Point Deep Metric Socket 6mm	-	

70 Pc. 1/4" and 3/8" Drive 6 and 12 Point SAE/Metric Mechanics Tool Set

- Contains a carefully selected assortment of hand tools needed for most industrial, mechanical and consumer applications
- Incredible access from longer wrenches with narrower heads as well as a new ratchet design with 10% longer beam and smaller teardrop head
- Innovative new hex key caddy makes accessing the size you need quick and easy
- Acetate magnetic bit driver for improved impact, UV, and solvent resistance
- Manufactured from chrome alloy steel for better strength and longer tool life
- Includes blow mold case for storage and organization
- Meets or exceeds ANSI and ASME specifications



Cat. No.	Included Storage	Product Weight
CTK70MPN	Blow Mold Case	8.500 lb

Cat. No.	Description	Cat. No.	Description
CRW0N	1/4" Drive 60 Tooth Quick Release Teardrop Ratchet 6"	CDS28N	3/8" Drive 12 Point Standard SAE Socket 9/16"
CRW6N	3/8" Drive 60 Tooth Quick Release Teardrop Ratchet 9"	CDS29N	3/8" Drive 12 Point Standard SAE Socket 5/8"
CDTA6N	1/4" Drive Extension 2"	CDS30N	3/8" Drive 12 Point Standard SAE Socket 11/16"
CDTA8N	3/8" Drive Extension 3"	CDS31N	3/8" Drive 12 Point Standard SAE Socket 3/4"
CDTA1N	3/8" Drive 3/8" F x 1/4" M Adapter	CDS40N	3/8" Drive 12 Point Standard Metric Socket 10mm
CDS0N	1/4" Drive 6 Point Standard SAE Socket 5/32"	CDS41N	3/8" Drive 12 Point Standard Metric Socket 11mm
CDS1N	1/4" Drive 6 Point Standard SAE Socket 3/16"	CDS42N	3/8" Drive 12 Point Standard Metric Socket 12mm
CDS2N	1/4" Drive 6 Point Standard SAE Socket 7/32"	CDS43N	3/8" Drive 12 Point Standard Metric Socket 13mm
CDS3N	1/4" Drive 6 Point Standard SAE Socket 1/4"	CDS44N	3/8" Drive 12 Point Standard Metric Socket 14mm
CDS4N	1/4" Drive 6 Point Standard SAE Socket 9/32"	CDS45N	3/8" Drive 12 Point Standard Metric Socket 15mm
CDS5N	1/4" Drive 6 Point Standard SAE Socket 5/16"	CDS47N	3/8" Drive 12 Point Standard Metric Socket 17mm
CDS6N	1/4" Drive 6 Point Standard SAE Socket 11/32"	CCW3	3/8" 12 Point Combination Wrench
CDS7N	1/4" Drive 6 Point Standard SAE Socket 3/8"	CCW4	7/16" 12 Point Combination Wrench
CDS8N	1/4" Drive 6 Point Standard SAE Socket 7/16"	CCW5	1/2" 12 Point Combination Wrench
CDS11N	1/4" Drive 6 Point Standard Metric Socket 4mm	CCW6	9/16" 12 Point Combination Wrench
CDS12N	1/4" Drive 6 Point Standard Metric Socket 5mm	CCW7	5/8" 12 Point Combination Wrench
CDS13N	1/4" Drive 6 Point Standard Metric Socket 6mm	CCW8	11/16" 12 Point Combination Wrench
CDS14N	1/4" Drive 6 Point Standard Metric Socket 7mm	CCW21	10mm 12 Point Combination Wrench
CDS15N	1/4" Drive 6 Point Standard Metric Socket 8mm	CCW23	12mm 12 Point Combination Wrench
CDS16N	1/4" Drive 6 Point Standard Metric Socket 9mm	CCW24	13mm 12 Point Combination Wrench
CDS17N	1/4" Drive 6 Point Standard Metric Socket 10mm	CCW25	14mm 12 Point Combination Wrench
CDS18N	1/4" Drive 6 Point Standard Metric Socket 11mm	CCW26	15mm 12 Point Combination Wrench
CDS19N	1/4" Drive 6 Point Standard Metric Socket 12mm	CCW28	17mm 12 Point Combination Wrench
CDS25N	3/8" Drive 12 Point Standard SAE Socket 3/8"	CRW25N	1/4" Drive Magnetic Bit Holding Screwdriver Handle
CDS26N	3/8" Drive 12 Point Standard SAE Socket 7/16"	-	12 Assorted Insert Bits in Holder
CDS27N	3/8" Drive 12 Point Standard SAE Socket 1/2"	-	8 Short Arm SAE Hex Keys with Caddie

45 Pc. 1/4" and 3/8" Drive 6 and 12 Point SAE/Metric Mechanics Tool Set

- 60-tooth ratchet requires only a 6-degree swing arc to turn a fastener
- Teardrop ratchet head for improved access
- Quick release design allows for rapid socket removal
- Sockets feature off-corner loading technology to virtually eliminate fastener rounding
- Manufactured from chrome alloy steel for better strength and longer tool life
- Includes blow mold case for storage and organization
- Meets or exceeds ASME and ANSI specifications



Cat. No.	Included Storage	Product Weight
CSWS13N	Blow Mold Case	5.150 lb

Cat. No.	Description	Cat. No.	Description
CRW6N	3/8" Drive 60 Tooth Quick Release Teardrop Ratchet 9"	CDS20N	1/4" Drive 6 Point Standard Metric Socket 13mm
CRW4N	1/4" Socket Driver	CDS24N	3/8" Drive 12 Point Standard SAE Socket 5/16"
CDTA8N	3/8" Drive Extension 3"	CDS25N	3/8" Drive 12 Point Standard SAE Socket 3/8"
CDTA1N	3/8" Drive 3/8" F x 1/4" M Adapter	CDS26N	3/8" Drive 12 Point Standard SAE Socket 7/16"
CDS0N	1/4" Drive 6 Point Standard SAE Socket 5/32"	CDS27N	3/8" Drive 12 Point Standard SAE Socket 1/2"
CDS1N	1/4" Drive 6 Point Standard SAE Socket 3/16"	CDS28N	3/8" Drive 12 Point Standard SAE Socket 9/16"
CDS2N	1/4" Drive 6 Point Standard SAE Socket 7/32"	CDS29N	3/8" Drive 12 Point Standard SAE Socket 5/8"
CDS3N	1/4" Drive 6 Point Standard SAE Socket 1/4"	CDS30N	3/8" Drive 12 Point Standard SAE Socket 11/16"
CDS4N	1/4" Drive 6 Point Standard SAE Socket 9/32"	CDS31N	3/8" Drive 12 Point Standard SAE Socket 3/4"
CDS5N	1/4" Drive 6 Point Standard SAE Socket 5/16"	CDS32N	3/8" Drive 12 Point Standard SAE Socket 13/16"
CDS6N	1/4" Drive 6 Point Standard SAE Socket 11/32"	CDS40N	3/8" Drive 12 Point Standard Metric Socket 10mm
CDS7N	1/4" Drive 6 Point Standard SAE Socket 3/8"	CDS41N	3/8" Drive 12 Point Standard Metric Socket 11mm
CDS8N	1/4" Drive 6 Point Standard SAE Socket 7/16"	CDS42N	3/8" Drive 12 Point Standard Metric Socket 12mm
CDS9N	1/4" Drive 6 Point Standard SAE Socket 1/2"	CDS43N	3/8" Drive 12 Point Standard Metric Socket 13mm
CDS11N	1/4" Drive 6 Point Standard Metric Socket 4mm	CDS44N	3/8" Drive 12 Point Standard Metric Socket 14mm
CDS12N	1/4" Drive 6 Point Standard Metric Socket 5mm	CDS45N	3/8" Drive 12 Point Standard Metric Socket 15mm
CDS13N	1/4" Drive 6 Point Standard Metric Socket 6mm	CDS46N	3/8" Drive 12 Point Standard Metric Socket 16mm
CDS14N	1/4" Drive 6 Point Standard Metric Socket 7mm	CDS47N	3/8" Drive 12 Point Standard Metric Socket 17mm
CDS15N	1/4" Drive 6 Point Standard Metric Socket 8mm	CDS48N	3/8" Drive 12 Point Standard Metric Socket 18mm
CDS16N	1/4" Drive 6 Point Standard Metric Socket 9mm	CDS49N	3/8" Drive 12 Point Standard Metric Socket 19mm
CDS17N	1/4" Drive 6 Point Standard Metric Socket 10mm	CSPS0N	3/8" Drive 6 Point 2-1/2" Spark Plug Socket 5/8"
CDS18N	1/4" Drive 6 Point Standard Metric Socket 11mm	CSPS2N	3/8" Drive 6 Point 2-1/2" Spark Plug Socket 13/16"
CDS19N	1/4" Drive 6 Point Standard Metric Socket 12mm		

12 Pc. 1/4" and 3/8" Drive Torx® Bit Socket Set

- Manufactured from chrome alloy steel for better strength and longer tool life
- Size markings stamped on base for quick size identification
- Insert bits made of S2 steel for strength and durability
- Nickel chrome plated base for durability
- Meets or exceeds ASME specifications



Cat. No.	Included Storage	Product Weight
CBSS2N	None	0.890 lb

Cat. No.	Description	Cat. No.	Description
CDTS0N	1/4" Drive Torx® Bit Socket T10	GDTS6N	3/8" Drive Torx® Bit Socket T40
CDTS1N	1/4" Drive Torx® Bit Socket T15	GDTS7N	3/8" Drive Torx® Bit Socket T45
CDTS2N	1/4" Drive Torx® Bit Socket T20	GDTS8N	3/8" Drive Torx® Bit Socket T47
CDTS3N	1/4" Drive Torx® Bit Socket T25	GDTS9N	3/8" Drive Torx® Bit Socket T50
CDTS4N	1/4" Drive Torx® Bit Socket T27	GDTS10N	3/8" Drive Torx® Bit Socket T55
CDTS5N	1/4" Drive Torx® Bit Socket T30	GDTS11N	3/8" Drive Torx® Bit Socket T60

12 Pc. 1/4" and 3/8" Drive Tamper Proof Torx® Bit Socket Set

- Manufactured from chrome alloy steel for better strength and longer tool life
- Size markings stamped on base for quick size identification
- Insert bits made of S2 steel for strength and durability
- Nickel chrome plated base for durability
- Meets or exceeds ASME specifications



Cat. No.	Included Storage	Product Weight
CBSS2TN	None	0.890 lb

Cat. No.	Description	Cat. No.	Description
-	1/4" Drive Tamper-Proof Torx® Bit Socket T10	-	3/8" Drive Tamper-Proof Torx® Bit Socket T40
-	1/4" Drive Tamper-Proof Torx® Bit Socket T15	-	3/8" Drive Tamper-Proof Torx® Bit Socket T45
-	1/4" Drive Tamper-Proof Torx® Bit Socket T20	-	3/8" Drive Tamper-Proof Torx® Bit Socket T47
-	1/4" Drive Tamper-Proof Torx® Bit Socket T25	-	3/8" Drive Tamper-Proof Torx® Bit Socket T50
-	1/4" Drive Tamper-Proof Torx® Bit Socket T27	-	3/8" Drive Tamper-Proof Torx® Bit Socket T55
-	1/4" Drive Tamper-Proof Torx® Bit Socket T30	-	3/8" Drive Tamper-Proof Torx® Bit Socket T60

MULTI-DRIVE

MULTI-DRIVE

16 Piece Socket Accessories Set

- Covers 1/4" to 3/4" drive sizes
- Manufactured from chrome alloy steel for better strength and longer tool life
- Bright, full polish chrome finish easily wipes clean and resists corrosion
- Includes 18" breaker bar
- Includes all the adapters needed for most jobs
- Meets or exceeds ASME specifications



Cat. No.	Included Storage	Product Weight
CTK16ASET	Blow Mold Case	7.800 lb

Cat. No.	Description	Cat. No.	Description
CRW15N	3/8" Drive Full Polish Flex Handle 10"	CDTA13N	1/2" Drive Extension 10"
CRW16N	1/2" Drive Full Polish Flex Handle 18"	CDTA0N	1/4" Drive 1/4" F x 3/8" M Adapter
-	1/4" Drive Extension 3"	CDTA1N	3/8" Drive 3/8" F x 1/4" M Adapter
CDTA7N	1/4" Drive Extension 6"	CDTA2N	3/8" Drive 3/8" F x 1/2" M Adapter
CDTA8N	3/8" Drive Extension 3"	CDTA3N	1/2" Drive 1/2" F x 3/8" M Adapter
CDTA9N	3/8" Drive Extension 6"	CDTA4N	1/2" Drive 1/2" F x 3/4" M Adapter
CDTA10N	3/8" Drive Extension 10"	CDTA16N	1/4" Drive Universal Joint
CDTA12N	1/2" Drive Extension 5"	CDTA17N	3/8" Drive Universal Joint

3 Pc. 1/4" 3/8" & 1/2" Drive Extension Set

- Manufactured from chrome alloy steel for better strength and longer tool life
- Nickel chrome plated for long-lasting protection
- Ball detent for secure socket retention
- Meets or exceeds ASME specifications



Cat. No.	Included Storage	Product Weight
CDTA15MDN	None	1.320 lb

Cat. No.	Description
CDTA6N	1/4" Drive Extension 2"
CDTA9N	3/8" Drive Extension 6"
CDTA13N	1/2" Drive Extension 10"

3 Pc. 1/4" and 3/8" Drive Universal Adapter Set

- Manufactured from chrome alloy steel for better strength and longer tool life
- Nickel chrome plated for long-lasting protection
- Ball detent for secure socket retention
- Meets or exceeds ASME specifications



Cat. No.	Included Storage	Product Weight
CDTA14N	None	0.290 lb

Cat. No.	Description
CDTA1N	3/8" Drive 3/8" F x 1/4" M Adapter
CDTA16N	1/4" Drive Universal Joint
CDTA17N	3/8" Drive Universal Joint

20 Pc. 1/4" Drive 6 Point SAE/Metric Socket Wrench Tool Set

- 60-tooth ratchet requires only a 6-degree swing arc to turn a fastener
- Teardrop ratchet head for improved access
- Quick release design allows for rapid socket removal
- Sockets feature off-corner loading technology to virtually eliminate fastener rounding
- Manufactured from chrome alloy steel for better strength and longer tool life
- Meets or exceeds ASME and ANSI specifications



Cat. No.	Included Storage	Product Weight
CSWS1N	None	1.255 lb

Cat. No.	Description	Cat. No.	Description
CRWON	1/4" Drive 60 Tooth Quick Release Teardrop Ratchet 6"	CDS9N	1/4" Drive 6 Point Standard SAE Socket 1/2"
CDTA6N	1/4" Drive Extension 2"	CDS12N	1/4" Drive 6 Point Standard Metric Socket 5mm
CDS1N	1/4" Drive 6 Point Standard SAE Socket 3/16"	CDS13N	1/4" Drive 6 Point Standard Metric Socket 6mm
CDS2N	1/4" Drive 6 Point Standard SAE Socket 7/32"	CDS14N	1/4" Drive 6 Point Standard Metric Socket 7mm
CDS3N	1/4" Drive 6 Point Standard SAE Socket 1/4"	CDS15N	1/4" Drive 6 Point Standard Metric Socket 8mm
CDS4N	1/4" Drive 6 Point Standard SAE Socket 9/32"	CDS16N	1/4" Drive 6 Point Standard Metric Socket 9mm
CDS5N	1/4" Drive 6 Point Standard SAE Socket 5/16"	CDS17N	1/4" Drive 6 Point Standard Metric Socket 10mm
CDS6N	1/4" Drive 6 Point Standard SAE Socket 11/32"	CDS18N	1/4" Drive 6 Point Standard Metric Socket 11mm
CDS7N	1/4" Drive 6 Point Standard SAE Socket 3/8"	CDS19N	1/4" Drive 6 Point Standard Metric Socket 12mm
CDS8N	1/4" Drive 6 Point Standard SAE Socket 7/16"	CDS20N	1/4" Drive 6 Point Standard Metric Socket 13mm



MULTI-DRIVE

1/4" DRIVE

21 Pc. 1/4" Drive 6 Point SAE Mechanics Tool Set

- 60-tooth ratchet requires only a 6-degree swing arc to turn a fastener
- Teardrop ratchet head for improved access
- Quick release design allows for rapid socket removal
- Sockets feature off-corner loading technology to virtually eliminate fastener rounding
- Manufactured from chrome alloy steel for better strength and longer tool life
- Includes blow mold case for storage and organization
- Meets or exceeds ASME and ANSI specifications



Cat. No.	Included Storage	Product Weight
CSWS2N	Blow Mold Case	2.000 lb

Cat. No.	Description	Cat. No.	Description
CRWON	1/4" Drive 60 Tooth Quick Release Teardrop Ratchet 6"	CDS9N	1/4" Drive 6 Point Standard SAE Socket 1/2"
CDTA7N	1/4" Drive Extension 6"	CDDS1N	1/4" Drive 6 Point Deep SAE Socket 3/16"
CDS0N	1/4" Drive 6 Point Standard SAE Socket 5/32"	CDDS2N	1/4" Drive 6 Point Deep SAE Socket 7/32"
CDS1N	1/4" Drive 6 Point Standard SAE Socket 3/16"	CDDS3N	1/4" Drive 6 Point Deep SAE Socket 1/4"
CDS2N	1/4" Drive 6 Point Standard SAE Socket 7/32"	CDDS4N	1/4" Drive 6 Point Deep SAE Socket 9/32"
CDS3N	1/4" Drive 6 Point Standard SAE Socket 1/4"	CDDS5N	1/4" Drive 6 Point Deep SAE Socket 5/16"
CDS4N	1/4" Drive 6 Point Standard SAE Socket 9/32"	CDDS6N	1/4" Drive 6 Point Deep SAE Socket 11/32"
CDS5N	1/4" Drive 6 Point Standard SAE Socket 5/16"	CDDS7N	1/4" Drive 6 Point Deep SAE Socket 3/8"
CDS6N	1/4" Drive 6 Point Standard SAE Socket 11/32"	CDDS8N	1/4" Drive 6 Point Deep SAE Socket 7/16"
CDS7N	1/4" Drive 6 Point Standard SAE Socket 3/8"	CDDS9N	1/4" Drive 6 Point Deep SAE Socket 1/2"
CDS8N	1/4" Drive 6 Point Standard SAE Socket 7/16"		

22 Pc. 1/4" Drive 6 Point Metric Mechanics Tool Set

- 60-tooth ratchet requires only a 6-degree swing arc to turn a fastener
- Teardrop ratchet head for improved access
- Quick release design allows for rapid socket removal
- Sockets feature off-corner loading technology to virtually eliminate fastener rounding
- Manufactured from chrome alloy steel for better strength and longer tool life
- Includes blow mold case for storage and organization
- Meets or exceeds ASME and ANSI specifications



Cat. No.	Included Storage	Product Weight
CSWS3N	Blow Mold Case	2.140 lb

Cat. No.	Description	Cat. No.	Description
CRWON	1/4" Drive 60 Tooth Quick Release Teardrop Ratchet 6"	CDS20N	1/4" Drive 6 Point Standard Metric Socket 13mm
CDTA7N	1/4" Drive Extension 6"	CDDS11N	1/4" Drive 6 Point Deep Metric Socket 4mm
CDS11N	1/4" Drive 6 Point Standard Metric Socket 4mm	CDDS12N	1/4" Drive 6 Point Deep Metric Socket 5mm

Cat. No.	Description	Cat. No.	Description
CDS12N	1/4" Drive 6 Point Standard Metric Socket 5mm	CDDS13N	1/4" Drive 6 Point Deep Metric Socket 6mm
CDS13N	1/4" Drive 6 Point Standard Metric Socket 6mm	CDDS14N	1/4" Drive 6 Point Deep Metric Socket 7mm
CDS14N	1/4" Drive 6 Point Standard Metric Socket 7mm	CDDS15N	1/4" Drive 6 Point Deep Metric Socket 8mm
CDS15N	1/4" Drive 6 Point Standard Metric Socket 8mm	CDDS16N	1/4" Drive 6 Point Deep Metric Socket 9mm
CDS16N	1/4" Drive 6 Point Standard Metric Socket 9mm	CDDS17N	1/4" Drive 6 Point Deep Metric Socket 10mm
CDS17N	1/4" Drive 6 Point Standard Metric Socket 10mm	CDDS18N	1/4" Drive 6 Point Deep Metric Socket 11mm
CDS18N	1/4" Drive 6 Point Standard Metric Socket 11mm	CDDS19N	1/4" Drive 6 Point Deep Metric Socket 12mm
CDS19N	1/4" Drive 6 Point Standard Metric Socket 12mm	CDDS20N	1/4" Drive 6 Point Deep Metric Socket 13mm

12 Pc. 1/4" Drive 6 Point SAE Mechanics Tool Set

- 60-tooth ratchet requires only a 6-degree swing arc to turn a fastener
- Teardrop ratchet head for improved access
- Quick release design allows for rapid socket removal
- Sockets feature off-corner loading technology to virtually eliminate fastener rounding
- Manufactured from chrome alloy steel for better strength and longer tool life
- Includes blow mold case for storage and organization
- Meets or exceeds ASME and ANSI specifications



Cat. No.	Included Storage	Product Weight
CSWS14SAE12	Blow Mold Case	1.555 lb

Cat. No.	Description	Cat. No.	Description
CRWON	1/4" Drive 60 Tooth Quick Release Teardrop Ratchet 6"	CDS4N	1/4" Drive 6 Point Standard SAE Socket 9/32"
-	1/4" Drive Extension 3"	CDS5N	1/4" Drive 6 Point Standard SAE Socket 5/16"
CDS0N	1/4" Drive 6 Point Standard SAE Socket 5/32"	CDS6N	1/4" Drive 6 Point Standard SAE Socket 11/32"
CDS1N	1/4" Drive 6 Point Standard SAE Socket 3/16"	CDS7N	1/4" Drive 6 Point Standard SAE Socket 3/8"
CDS2N	1/4" Drive 6 Point Standard SAE Socket 7/32"	CDS8N	1/4" Drive 6 Point Standard SAE Socket 7/16"
CDS3N	1/4" Drive 6 Point Standard SAE Socket 1/4"	CDS9N	1/4" Drive 6 Point Standard SAE Socket 1/2"

12 Pc. 1/4" Drive 6 Point Metric Mechanics Tool Set

- 60-tooth ratchet requires only a 6-degree swing arc to turn a fastener
- Teardrop ratchet head for improved access
- Quick release design allows for rapid socket removal
- Sockets feature off-corner loading technology to virtually eliminate fastener rounding
- Manufactured from chrome alloy steel for better strength and longer tool life
- Includes blow mold case for storage and organization
- Meets or exceeds ASME and ANSI specifications



Cat. No.	Included Storage	Product Weight
CSWS14MM12	Blow Mold Case	1.575 lb

Cat. No.	Description	Cat. No.	Description
CRWON	1/4" Drive 60 Tooth Quick Release Teardrop Ratchet 6"	CDS16N	1/4" Drive 6 Point Standard Metric Socket 9mm
-	1/4" Drive Extension 3"	CDS17N	1/4" Drive 6 Point Standard Metric Socket 10mm
CDS12N	1/4" Drive 6 Point Standard Metric Socket 5mm	CDS18N	1/4" Drive 6 Point Standard Metric Socket 11mm
CDS13N	1/4" Drive 6 Point Standard Metric Socket 6mm	CDS19N	1/4" Drive 6 Point Standard Metric Socket 12mm
CDS14N	1/4" Drive 6 Point Standard Metric Socket 7mm	CDS20N	1/4" Drive 6 Point Standard Metric Socket 13mm
CDS15N	1/4" Drive 6 Point Standard Metric Socket 8mm	-	1/4" Drive 6 Point Standard Metric Socket 14mm

10 Pc. 1/4" Drive 6 Point Standard SAE Socket Set

- Manufactured from chrome alloy steel for better strength and longer tool life
- Off-corner loading technology to virtually eliminate fastener rounding
- Size markings stamped on socket for quick size identification
- Nickel chrome plated for durability
- Meets or exceeds ASME specifications



Cat. No.	Included Storage	Product Weight
CSAS8N	Socket Rail	0.450 lb

Cat. No.	Description	Cat. No.	Description
CDS0N	1/4" Drive 6 Point Standard SAE Socket 5/32"	CDS5N	1/4" Drive 6 Point Standard SAE Socket 5/16"
CDS1N	1/4" Drive 6 Point Standard SAE Socket 3/16"	CDS6N	1/4" Drive 6 Point Standard SAE Socket 11/32"
CDS2N	1/4" Drive 6 Point Standard SAE Socket 7/32"	CDS7N	1/4" Drive 6 Point Standard SAE Socket 3/8"
CDS3N	1/4" Drive 6 Point Standard SAE Socket 1/4"	CDS8N	1/4" Drive 6 Point Standard SAE Socket 7/16"
CDS4N	1/4" Drive 6 Point Standard SAE Socket 9/32"	CDS9N	1/4" Drive 6 Point Standard SAE Socket 1/2"

10 Pc. 1/4" Drive 6 Point Standard Metric Socket Set

- Manufactured from chrome alloy steel for better strength and longer tool life
- Off-corner loading technology to virtually eliminate fastener rounding
- Size markings stamped on socket for quick size identification
- Nickel chrome plated for durability
- Meets or exceeds ASME specifications



Cat. No.	Included Storage	Product Weight
CSAS9N	Socket Rail	0.490 lb

Cat. No.	Description	Cat. No.	Description
CDS11N	1/4" Drive 6 Point Standard Metric Socket 4mm	CDS16N	1/4" Drive 6 Point Standard Metric Socket 9mm
CDS12N	1/4" Drive 6 Point Standard Metric Socket 5mm	CDS17N	1/4" Drive 6 Point Standard Metric Socket 10mm
CDS13N	1/4" Drive 6 Point Standard Metric Socket 6mm	CDS18N	1/4" Drive 6 Point Standard Metric Socket 11mm
CDS14N	1/4" Drive 6 Point Standard Metric Socket 7mm	CDS19N	1/4" Drive 6 Point Standard Metric Socket 12mm
CDS15N	1/4" Drive 6 Point Standard Metric Socket 8mm	CDS20N	1/4" Drive 6 Point Standard Metric Socket 13mm

10 Pc. 1/4" Drive 6 Point Deep SAE Socket Set

- Manufactured from chrome alloy steel for better strength and longer tool life
- Off-corner loading technology to virtually eliminate fastener rounding
- Size markings stamped on socket for quick size identification
- Nickel chrome plated for durability
- Meets or exceeds ASME specifications



Cat. No.	Included Storage	Product Weight
CSAS10N	Socket Rail	0.785 lb

Cat. No.	Description	Cat. No.	Description
CDDS0N	1/4" Drive 6 Point Deep SAE Socket 5/32"	CDDS5N	1/4" Drive 6 Point Deep SAE Socket 5/16"
CDDS1N	1/4" Drive 6 Point Deep SAE Socket 3/16"	CDDS6N	1/4" Drive 6 Point Deep SAE Socket 11/32"
CDDS2N	1/4" Drive 6 Point Deep SAE Socket 7/32"	CDDS7N	1/4" Drive 6 Point Deep SAE Socket 3/8"
CDDS3N	1/4" Drive 6 Point Deep SAE Socket 1/4"	CDDS8N	1/4" Drive 6 Point Deep SAE Socket 7/16"
CDDS4N	1/4" Drive 6 Point Deep SAE Socket 9/32"	CDDS9N	1/4" Drive 6 Point Deep SAE Socket 1/2"

10 Pc. 1/4" Drive 6 Point Deep Metric Socket Set

- Manufactured from chrome alloy steel for better strength and longer tool life
- Off-corner loading technology to virtually eliminate fastener rounding
- Size markings stamped on socket for quick size identification
- Nickel chrome plated for durability
- Meets or exceeds ASME specifications



Cat. No.	Included Storage	Product Weight
CSAS11N	Socket Rail	0.810 lb

Cat. No.	Description	Cat. No.	Description
CDDS11N	1/4" Drive 6 Point Deep Metric Socket 4mm	CDDS16N	1/4" Drive 6 Point Deep Metric Socket 9mm
CDDS12N	1/4" Drive 6 Point Deep Metric Socket 5mm	CDDS17N	1/4" Drive 6 Point Deep Metric Socket 10mm
CDDS13N	1/4" Drive 6 Point Deep Metric Socket 6mm	CDDS18N	1/4" Drive 6 Point Deep Metric Socket 11mm
CDDS14N	1/4" Drive 6 Point Deep Metric Socket 7mm	CDDS19N	1/4" Drive 6 Point Deep Metric Socket 12mm
CDDS15N	1/4" Drive 6 Point Deep Metric Socket 8mm	CDDS20N	1/4" Drive 6 Point Deep Metric Socket 13mm

1/4" Drive Quick Release 60 Tooth Teardrop Ratchet

- 60-tooth ratchet turns fasteners with a 6° swing arc
- Extra-long handle for improved access
- Quick-release design allows for rapid socket removal
- Teardrop head for improved access
- Manufactured from chrome alloy steel for better strength and longer tool life
- Bright, full polish chrome finish easily wipes clean and resists corrosion
- Meets or exceeds ASME specifications



Cat. No.	Overall Length	Head Width	Head Thickness	Tooth Count	Product Weight
CRW0N	6 in	.98 in	.48 in	60	0.370 lb

1/4" Drive Flex Handle/Breaker Bar 6"

- Flexible head for better access
- Long handle for greater torque
- Manufactured from chrome alloy steel for better strength and longer tool life
- Bright, full polish chrome finish easily wipes clean and resists corrosion
- Meets or exceeds ASME specifications



Cat. No.	Overall Length	Product Weight
CRW5N	6 in	0.290 lb

1/4" Drive Quick Release 72 Tooth Dual Material Ratchet

- 72-tooth ratchet turns fasteners with a 5° swing arc
- Quick-release design allows for rapid socket removal
- Teardrop head for improved access
- Manufactured from chrome vanadium alloy steel for better strength and longer tool life
- Dual material comfort grip handle
- Nickel chrome plated for long-lasting protection
- Meets or exceeds ASME specifications



Cat. No.	Overall Length	Head Width	Tooth Count	Product Weight
CRW1	6.69 in	1.1 in	72	0.44 lb

1/4" Drive Spinner Handle

- Spinner handle for turning 1/4" Drive sockets is 7" long for access
- Ball detent for secure socket retention
- Acetate handle for improved impact, UV, and solvent resistance
- Manufactured from chrome alloy steel for better strength and longer tool life
- Meets or exceeds ASME specifications



Cat. No.	Overall Length	Head Width	Product Weight
CRW4N	7 in	1.05 in	0.230 lb

1/4" Drive Extensions

- Manufactured from chrome alloy steel for better strength and longer tool life
- Bright, full polish chrome finish easily wipes clean and resists corrosion
- Ball detent for secure socket retention
- Meets or exceeds ASME specifications



Cat. No.	Overall Length	Wobble	Product Weight
CDTA6N	2 in	No	0.070 lb
CDTA7N	6 in	No	0.160 lb

1/4" Drive Adapters

- Manufactured from chrome alloy steel for better strength and longer tool life
- Bright, full polish chrome finish easily wipes clean and resists corrosion
- Ball detent for secure socket retention
- Meets or exceeds ASME specifications



Cat. No.	Overall Length	Female Drive Size	Male Drive Size	Product Weight
CDTA0N	1 in	1/4"	3/8"	0.060 lb

1/4" Drive Universal Joint

- Universal joint gives improved access to hard to reach fasteners
- Manufactured from chrome alloy steel for better strength and longer tool life
- Bright, full polish chrome finish easily wipes clean and resists corrosion
- Ball detent for secure socket retention
- Meets or exceeds ASME specifications



Cat. No.	Overall Length	Product Weight
CDTA16N	1.45 in	0.070 lb

1/4" Drive 6 Point Standard Sockets

- Manufactured from chrome alloy steel for better strength and longer tool life
- Off-corner loading technology to virtually eliminate fastener rounding
- Size markings stamped on socket for quick size identification
- Nickel chrome plated for durability
- Meets or exceeds ASME specifications

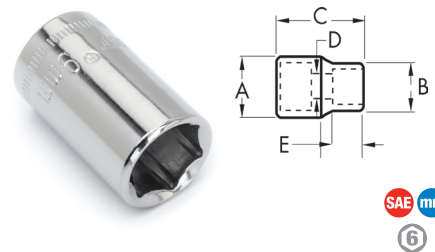

Cat. No.	SAE/Metric	Fastener Size	Dim. A: Drive End	Dim. B: Wrench End	Dim. C: Overall Length	Dim. D: Bolt Clearance	Dim. E: Wrench Depth	Product Weight
CDS0N	SAE	5/32 in	0.45 in	0.28 in	0.88 in	0.09 in	0.22 in	0.040 lb
CDS1N	SAE	3/16 in	0.45 in	0.31 in	0.88 in	0.12 in	0.22 in	0.040 lb
CDS2N	SAE	7/32 in	0.45 in	0.35 in	0.88 in	0.12 in	0.22 in	0.040 lb
CDS3N	SAE	1/4 in	0.45 in	0.39 in	0.88 in	0.16 in	0.22 in	0.040 lb
CDS4N	SAE	9/32 in	0.45 in	0.42 in	0.88 in	0.16 in	0.35 in	0.040 lb
CDS5N	SAE	5/16 in	0.46 in	0.46 in	0.88 in	0.21 in	0.35 in	0.040 lb
CDS6N	SAE	11/32 in	0.51 in	0.51 in	0.88 in	0.21 in	0.35 in	0.050 lb
CDS7N	SAE	3/8 in	0.55 in	0.55 in	0.88 in	0.291 in	0.50 in	0.050 lb
CDS8N	SAE	7/16 in	0.62 in	0.62 in	0.88 in	0.496 in	0.50 in	0.070 lb

Cat. No.	SAE/Metric	Fastener Size	Dim. A: Drive End	Dim. B: Wrench End	Dim. C: Overall Length	Dim. D: Bolt Clearance	Dim. E: Wrench Depth	Product Weight
CDS9N	SAE	1/2 in	0.69 in	0.69 in	0.88 in	0.496 in	0.50 in	0.080 lb
CDS11N	Metric	4 mm	0.45 in	0.28 in	0.88 in	0.09 in	0.18 in	0.040 lb
CDS12N	Metric	5 mm	0.45 in	0.31 in	0.88 in	0.12 in	0.18 in	0.040 lb
CDS13N	Metric	6 mm	0.45 in	0.37 in	0.88 in	0.15 in	0.22 in	0.040 lb
CDS14N	Metric	7 mm	0.45 in	0.42 in	0.88 in	0.15 in	0.22 in	0.040 lb
CDS15N	Metric	8 mm	0.47 in	0.47 in	0.88 in	0.20 in	0.28 in	0.050 lb
CDS16N	Metric	9 mm	0.51 in	0.51 in	0.88 in	0.20 in	0.28 in	0.050 lb
CDS17N	Metric	10 mm	0.55 in	0.55 in	0.88 in	0.291 in	0.50 in	0.050 lb
CDS18N	Metric	11 mm	0.62 in	0.62 in	0.88 in	0.496 in	0.50 in	0.070 lb
CDS19N	Metric	12 mm	0.66 in	0.66 in	0.88 in	0.496 in	0.50 in	0.080 lb
CDS20N	Metric	13 mm	0.70 in	0.70 in	0.88 in	0.496 in	0.50 in	0.080 lb

1/4" Drive 6 Point Deep Sockets

- Manufactured from chrome alloy steel for better strength and longer tool life
- Off-corner loading technology to virtually eliminate fastener rounding
- Size markings stamped on socket for quick size identification
- Nickel chrome plated for durability
- Meets or exceeds ASME specifications

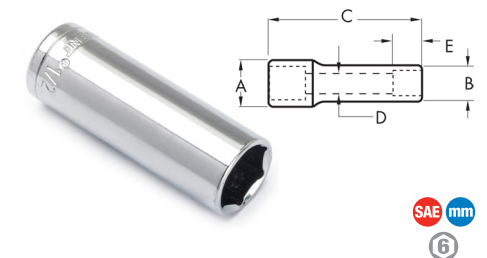

Cat. No.	SAE/Metric	Fastener Size	Dim. A: Drive End	Dim. B: Wrench End	Dim. C: Overall Length	Dim. D: Bolt Clearance	Dim. E: Wrench Depth	Product Weight
CDDS0N	SAE	5/32 in	0.45 in	0.28 in	2 in	0.09 in	0.22 in	0.060 lb
CDDS1N	SAE	3/16 in	0.45 in	0.30 in	2 in	0.12 in	0.22 in	0.060 lb
CDDS2N	SAE	7/32 in	0.45 in	0.35 in	2 in	0.12 in	0.22 in	0.060 lb
CDDS3N	SAE	1/4 in	0.45 in	0.39 in	2 in	0.16 in	0.22 in	0.070 lb
CDDS4N	SAE	9/32 in	0.45 in	0.42 in	2 in	0.16 in	0.22 in	0.070 lb
CDDS5N	SAE	5/16 in	0.45 in	0.45 in	2 in	0.21 in	0.80 in	0.070 lb
CDDS6N	SAE	11/32 in	0.51 in	0.51 in	2 in	0.21 in	0.80 in	0.080 lb
CDDS7N	SAE	3/8 in	0.57 in	0.57 in	2 in	0.826 in	0.80 in	0.100 lb
CDDS8N	SAE	7/16 in	0.62 in	0.62 in	2 in	0.826 in	0.80 in	0.110 lb
CDDS9N	SAE	1/2 in	0.68 in	0.68 in	2 in	0.826 in	0.80 in	0.130 lb
CDDS11N	Metric	4 mm	0.45 in	0.28 in	2 in	0.09 in	0.20 in	0.060 lb
CDDS12N	Metric	5 mm	0.45 in	0.32 in	2 in	0.12 in	0.20 in	0.060 lb
CDDS13N	Metric	6 mm	0.45 in	0.36 in	2 in	0.15 in	0.20 in	0.070 lb
CDDS14N	Metric	7 mm	0.45 in	0.42 in	2 in	0.15 in	0.20 in	0.070 lb
CDDS15N	Metric	8 mm	0.45 in	0.45 in	2 in	0.20 in	0.70 in	0.070 lb
CDDS16N	Metric	9 mm	0.51 in	0.51 in	2 in	0.20 in	0.70 in	0.080 lb
CDDS17N	Metric	10 mm	0.58 in	0.58 in	2 in	0.20 in	0.70 in	0.100 lb
CDDS18N	Metric	11 mm	0.62 in	0.62 in	2 in	0.20 in	0.70 in	0.110 lb

Continued on next page

1/4" DRIVE

1/4" DRIVE

1/4" Drive 6 Point Deep Sockets ■ Continued from previous page

Cat. No.	SAE/Metric	Fastener Size	Dim. A: Drive End	Dim. B: Wrench End	Dim. C: Overall Length	Dim. D: Bolt Clearance	Dim. E: Wrench Depth	Product Weight
CDDS19N	Metric	12 mm	0.66 in	0.66 in	2 in	0.20 in	0.70 in	0.120 lb
CDDS20N	Metric	13 mm	0.70 in	0.70 in	2 in	0.20 in	0.70 in	0.130 lb

1/4" Drive Torx® Bit Sockets

- Manufactured from chrome alloy steel for better strength and longer tool life
- Size markings stamped on base for quick size identification
- Insert bits made of S2 steel for strength and durability
- Nickel chrome plated base for durability
- Meets or exceeds ASME specifications

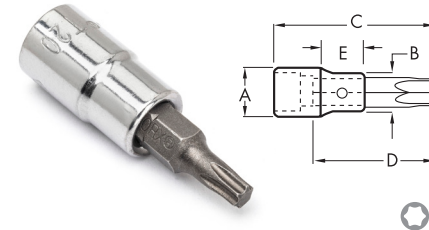

Cat. No.	Fastener Size	Dim. A: Drive End	Dim. B: Nose Diameter	Dim. C: Overall Length	Dim. D: Bit Length	Dim. E: Wrench Depth	Product Weight
CDTS0N	T10	.46 in	.25 in	1.58 in	1.1 in	.36 in	0.050 lb
CDTS1N	T15	.46 in	.25 in	1.58 in	1.1 in	.36 in	0.050 lb
CDTS2N	T20	.46 in	.25 in	1.58 in	1.1 in	.36 in	0.050 lb
CDTS3N	T25	.46 in	.25 in	1.58 in	1.1 in	.36 in	0.050 lb
CDTS4N	T27	.46 in	.25 in	1.58 in	1.1 in	.36 in	0.050 lb
CDTS5N	T30	.46 in	.25 in	1.58 in	1.1 in	.36 in	0.050 lb

1/4" Drive Socket Rail

- Perfect to store, organize, and easily find all your sockets
- Drilled at end for easy attachment to wall, workbench, or drawer
- Blue color for easy identification
- Includes 14 socket clips



Cat. No.	Drive Size	Color	Overall Length	Number of Clips	Product Weight
CSRO	1/4 in	Blue	17.5 in	14	0.40 lb

20 Pc. X10 3/8" Drive 6 Point SAE/Metric Mechanics Tool Set



- 84-tooth gear offers a 4.3° swing arc for easy access
- Teardrop ratchet head for improved access
- Enclosed ratchet head design for improved reliability in the harshest environments
- Sockets feature off-corner loading technology to virtually eliminate fastener rounding
- High contrast colored rings on sockets allow you to quickly differentiate and identify sizes
- Knurled surfaces on the ratchet and sockets give you better grip and control in slippery circumstances
- Manufactured from alloy steel for better strength and longer tool life
- Black manganese phosphate finish for extreme corrosion resistance and smooth-ground surfaces to reduce friction
- Meets or exceeds ASME and ANSI specifications

Cat. No.	Included Storage	Product Weight
CSWS38B	None	2.595 lb



Cat. No.	Description	Cat. No.	Description
-	3/8" Drive 84 Tooth Ratchet	-	3/8" Drive 6 Point Standard SAE Socket 13/16"
-	3/8" Drive Extension 3"	-	3/8" Drive 6 Point Standard Metric Socket 9mm
-	3/8" Drive 6 Point Standard SAE Socket 5/16"	-	3/8" Drive 6 Point Standard Metric Socket 10mm
-	3/8" Drive 6 Point Standard SAE Socket 3/8"	-	3/8" Drive 6 Point Standard Metric Socket 11mm
-	3/8" Drive 6 Point Standard SAE Socket 7/16"	-	3/8" Drive 6 Point Standard Metric Socket 12mm
-	3/8" Drive 6 Point Standard SAE Socket 1/2"	-	3/8" Drive 6 Point Standard Metric Socket 13mm
-	3/8" Drive 6 Point Standard SAE Socket 9/16"	-	3/8" Drive 6 Point Standard Metric Socket 14mm
-	3/8" Drive 6 Point Standard SAE Socket 5/8"	-	3/8" Drive 6 Point Standard Metric Socket 15mm
-	3/8" Drive 6 Point Standard SAE Socket 11/16"	-	3/8" Drive 6 Point Standard Metric Socket 17mm
-	3/8" Drive 6 Point Standard SAE Socket 3/4"	-	3/8" Drive 6 Point Standard Metric Socket 19mm

20 Pc. 3/8" Drive X6™ SAE/Metric Pass-Thru™ Mechanics Tool Set

- Pass-Thru™ system works over any length threaded rod, where normal ratchets and sockets won't fit
- Pass-Thru™ socket and ratchet system eliminates the need for deep sockets
- Fits six fastener types: Hex, Square, 12 pt., E-Torx®, Rounded Hex, and Spline
- Up to 50% thinner than standard ratchets to give you greater access
- Ratchet has just a 5° swing arc, so it can turn fasteners in very tight spaces
- Up to 40% stronger than standard ratchets
- Included adapter allows X6 box end to work with standard square 3/8-drive sockets
- Includes tray for storage and organization
- Meets or exceeds ANSI and ASME specifications
- Some square nuts & bolts may not engage with sockets



Cat. No.	Included Storage	Product Weight
CX6PT20	Tray	2.86 lb



Cat. No.	Description	Cat. No.	Description
-	3/8" Drive X6 Pass-Thru™ Ratchet	-	3/8" Drive Pass-Thru™ Spline SAE Socket 7/8"
-	3/8" Drive Pass-Thru™ Adapter	-	3/8" Drive Pass-Thru™ Spline Metric Socket 10mm
-	3/8" Drive Pass-Thru™ Spline SAE Socket 3/8"	-	3/8" Drive Pass-Thru™ Spline Metric Socket 11mm
-	3/8" Drive Pass-Thru™ Spline SAE Socket 7/16"	-	3/8" Drive Pass-Thru™ Spline Metric Socket 12mm
-	3/8" Drive Pass-Thru™ Spline SAE Socket 1/2"	-	3/8" Drive Pass-Thru™ Spline Metric Socket 13mm
-	3/8" Drive Pass-Thru™ Spline SAE Socket 9/16"	-	3/8" Drive Pass-Thru™ Spline Metric Socket 14mm
-	3/8" Drive Pass-Thru™ Spline SAE Socket 5/8"	-	3/8" Drive Pass-Thru™ Spline Metric Socket 15mm
-	3/8" Drive Pass-Thru™ Spline SAE Socket 11/16"	-	3/8" Drive Pass-Thru™ Spline Metric Socket 17mm
-	3/8" Drive Pass-Thru™ Spline SAE Socket 3/4"	-	3/8" Drive Pass-Thru™ Spline Metric Socket 18mm
-	3/8" Drive Pass-Thru™ Spline SAE Socket 13/16"	-	3/8" Drive Pass-Thru™ Spline Metric Socket 19mm

52 Pc. 3/8" Drive 6 and 12 Point SAE/Metric Mechanics Tool Set

- 60-tooth ratchet requires only a 6-degree swing arc to turn a fastener
- Teardrop ratchet head for improved access
- Quick release design allows for rapid socket removal
- Sockets feature off-corner loading technology to virtually eliminate fastener rounding
- Manufactured from chrome alloy steel for better strength and longer tool life
- Includes blow mold case for storage and organization
- Meets or exceeds ASME and ANSI specifications



Cat. No.	Included Storage	Product Weight
CSWS10N	Blow Mold Case	10.990 lb

Cat. No.	Description	Cat. No.	Description
CRW6N	3/8" Drive 60 Tooth Quick Release Teardrop Ratchet 9"	CDS49N	3/8" Drive 12 Point Standard Metric Socket 19mm
CDTA8N	3/8" Drive Extension 3"	CDDS23N	3/8" Drive 6 Point Deep SAE Socket 1/4"

Cat. No.	Description	Cat. No.	Description
CDTA9N	3/8" Drive Extension 6"	CDDS24N	3/8" Drive 6 Point Deep SAE Socket 5/16"
CDTA17N	3/8" Drive Universal Joint	CDDS25N	3/8" Drive 6 Point Deep SAE Socket 3/8"
CDS23N	3/8" Drive 12 Point Standard SAE Socket 1/4"	CDDS26N	3/8" Drive 6 Point Deep SAE Socket 7/16"
CDS24N	3/8" Drive 12 Point Standard SAE Socket 5/16"	CDDS27N	3/8" Drive 6 Point Deep SAE Socket 1/2"
CDS25N	3/8" Drive 12 Point Standard SAE Socket 3/8"	CDDS28N	3/8" Drive 6 Point Deep SAE Socket 9/16"
CDS26N	3/8" Drive 12 Point Standard SAE Socket 7/16"	CDDS29N	3/8" Drive 6 Point Deep SAE Socket 5/8"
CDS27N	3/8" Drive 12 Point Standard SAE Socket 1/2"	CDDS30N	3/8" Drive 6 Point Deep SAE Socket 11/16"
CDS28N	3/8" Drive 12 Point Standard SAE Socket 9/16"	CDDS31N	3/8" Drive 6 Point Deep SAE Socket 3/4"
CDS29N	3/8" Drive 12 Point Standard SAE Socket 5/8"	CDDS32N	3/8" Drive 6 Point Deep SAE Socket 13/16"
CDS30N	3/8" Drive 12 Point Standard SAE Socket 11/16"	CDDS33N	3/8" Drive 6 Point Deep SAE Socket 7/8"
CDS31N	3/8" Drive 12 Point Standard SAE Socket 3/4"	-	3/8" Drive 6 Point Deep Metric Socket 7mm
CDS32N	3/8" Drive 12 Point Standard SAE Socket 13/16"	CDDS38N	3/8" Drive 6 Point Deep Metric Socket 8mm
CDS33N	3/8" Drive 12 Point Standard SAE Socket 7/8"	CDDS39N	3/8" Drive 6 Point Deep Metric Socket 9mm
CDS38N	3/8" Drive 12 Point Standard Metric Socket 8mm	CDDS40N	3/8" Drive 6 Point Deep Metric Socket 10mm
CDS39N	3/8" Drive 12 Point Standard Metric Socket 9mm	CDDS41N	3/8" Drive 6 Point Deep Metric Socket 11mm
CDS40N	3/8" Drive 12 Point Standard Metric Socket 10mm	CDDS42N	3/8" Drive 6 Point Deep Metric Socket 12mm
CDS41N	3/8" Drive 12 Point Standard Metric Socket 11mm	CDDS43N	3/8" Drive 6 Point Deep Metric Socket 13mm
CDS42N	3/8" Drive 12 Point Standard Metric Socket 12mm	CDDS44N	3/8" Drive 6 Point Deep Metric Socket 14mm
CDS43N	3/8" Drive 12 Point Standard Metric Socket 13mm	CDDS45N	3/8" Drive 6 Point Deep Metric Socket 15mm
CDS44N	3/8" Drive 12 Point Standard Metric Socket 14mm	CDDS46N	3/8" Drive 6 Point Deep Metric Socket 16mm
CDS45N	3/8" Drive 12 Point Standard Metric Socket 15mm	CDDS47N	3/8" Drive 6 Point Deep Metric Socket 17mm
CDS46N	3/8" Drive 12 Point Standard Metric Socket 16mm	CDDS48N	3/8" Drive 6 Point Deep Metric Socket 18mm
CDS47N	3/8" Drive 12 Point Standard Metric Socket 17mm	CDDS49N	3/8" Drive 6 Point Deep Metric Socket 19mm
CDS48N	3/8" Drive 12 Point Standard Metric Socket 18mm	CSP50N	3/8" Drive 6 Point 2-1/2" Spark Plug Socket 5/8"

25 Pc. 3/8" Drive 6 and 12 Point SAE Mechanics Tool Set

- 60-tooth ratchet requires only a 6-degree swing arc to turn a fastener
- Teardrop ratchet head for improved access
- Quick release design allows for rapid socket removal
- Sockets feature off-corner loading technology to virtually eliminate fastener rounding
- Manufactured from chrome alloy steel for better strength and longer tool life
- Includes blow mold case for storage and organization
- Meets or exceeds ASME and ANSI specifications



Cat. No.	Included Storage	Product Weight
CSWS8N	Blow Mold Case	6.310 lb

Cat. No.	Description	Cat. No.	Description
CRW6N	3/8" Drive 60 Tooth Quick Release Teardrop Ratchet 9"	CDS33N	3/8" Drive 12 Point Standard SAE Socket 7/8"
CDTA8N	3/8" Drive Extension 3"	CDDS23N	3/8" Drive 6 Point Deep SAE Socket 1/4"

Continued on next page

25 Pc. 3/8" Drive 6 and 12 Point SAE Mechanics Tool Set

Continued from previous page

Cat. No.	Description	Cat. No.	Description
CDA9N	3/8" Drive Extension 6"	CDD24N	3/8" Drive 6 Point Deep SAE Socket 5/16"
CDS23N	3/8" Drive 12 Point Standard SAE Socket 1/4"	CDD25N	3/8" Drive 6 Point Deep SAE Socket 3/8"
CDS24N	3/8" Drive 12 Point Standard SAE Socket 5/16"	CDD26N	3/8" Drive 6 Point Deep SAE Socket 7/16"
CDS25N	3/8" Drive 12 Point Standard SAE Socket 3/8"	CDD27N	3/8" Drive 6 Point Deep SAE Socket 1/2"
CDS26N	3/8" Drive 12 Point Standard SAE Socket 7/16"	CDD28N	3/8" Drive 6 Point Deep SAE Socket 9/16"
CDS27N	3/8" Drive 12 Point Standard SAE Socket 1/2"	CDD29N	3/8" Drive 6 Point Deep SAE Socket 5/8"
CDS28N	3/8" Drive 12 Point Standard SAE Socket 9/16"	CDD30N	3/8" Drive 6 Point Deep SAE Socket 11/16"
CDS29N	3/8" Drive 12 Point Standard SAE Socket 5/8"	CDD31N	3/8" Drive 6 Point Deep SAE Socket 3/4"
CDS30N	3/8" Drive 12 Point Standard SAE Socket 11/16"	CDD32N	3/8" Drive 6 Point Deep SAE Socket 13/16"
CDS31N	3/8" Drive 12 Point Standard SAE Socket 3/4"	CDD33N	3/8" Drive 6 Point Deep SAE Socket 7/8"
CDS32N	3/8" Drive 12 Point Standard SAE Socket 13/16"		

27 Pc. 3/8" Drive 6 and 12 Point Metric Mechanics Tool Set

- 60-tooth ratchet requires only a 6-degree swing arc to turn a fastener
- Teardrop ratchet head for improved access
- Quick release design allows for rapid socket removal
- Sockets feature off-corner loading technology to virtually eliminate fastener rounding
- Manufactured from chrome alloy steel for better strength and longer tool life
- Includes blow mold case for storage and organization
- Meets or exceeds ASME and ANSI specifications



Cat. No.	Included Storage	Product Weight
CSWS9N	Blow Mold Case	6.030 lb

Cat. No.	Description	Cat. No.	Description
CRW6N	3/8" Drive 60 Tooth Quick Release Teardrop Ratchet 9"	CDS49N	3/8" Drive 12 Point Standard Metric Socket 19mm
CDTA8N	3/8" Drive Extension 3"	CDD38N	3/8" Drive 6 Point Deep Metric Socket 8mm
CDTA9N	3/8" Drive Extension 6"	CDD39N	3/8" Drive 6 Point Deep Metric Socket 9mm
CDS38N	3/8" Drive 12 Point Standard Metric Socket 8mm	CDD40N	3/8" Drive 6 Point Deep Metric Socket 10mm
CDS39N	3/8" Drive 12 Point Standard Metric Socket 9mm	CDD41N	3/8" Drive 6 Point Deep Metric Socket 11mm
CDS40N	3/8" Drive 12 Point Standard Metric Socket 10mm	CDD42N	3/8" Drive 6 Point Deep Metric Socket 12mm
CDS41N	3/8" Drive 12 Point Standard Metric Socket 11mm	CDD43N	3/8" Drive 6 Point Deep Metric Socket 13mm
CDS42N	3/8" Drive 12 Point Standard Metric Socket 12mm	CDD44N	3/8" Drive 6 Point Deep Metric Socket 14mm
CDS43N	3/8" Drive 12 Point Standard Metric Socket 13mm	CDD45N	3/8" Drive 6 Point Deep Metric Socket 15mm
CDS44N	3/8" Drive 12 Point Standard Metric Socket 14mm	CDD46N	3/8" Drive 6 Point Deep Metric Socket 16mm
CDS45N	3/8" Drive 12 Point Standard Metric Socket 15mm	CDD47N	3/8" Drive 6 Point Deep Metric Socket 17mm
CDS46N	3/8" Drive 12 Point Standard Metric Socket 16mm	CDD48N	3/8" Drive 6 Point Deep Metric Socket 18mm
CDS47N	3/8" Drive 12 Point Standard Metric Socket 17mm	CDD49N	3/8" Drive 6 Point Deep Metric Socket 19mm
CDS48N	3/8" Drive 12 Point Standard Metric Socket 18mm		

128 Pc. 3/8" Drive 12 Point SAE/Metric Standard Mechanics Tool Set

- Contains a carefully selected assortment of hand tools needed for most industrial, mechanical and consumer applications
- Incredible access from long wrenches with narrow heads, adjustable wrenches and pliers, and a long-beam ratchets with small teardrop heads
- Upgraded set includes Torx® bit sockets and Tamper-Proof Torx® driver bits
- Innovative new hex key caddy makes accessing the size you need quick and easy
- Acetate screwdrivers and magnetic bit driver for improved impact, UV, and solvent resistance
- Manufactured from chrome alloy steel for better strength and longer tool life
- Includes blow mold case for storage and organization
- Meets or exceeds ANSI and ASME specifications



Cat. No.	Included Storage	Product Weight
CTK128MP2N	Blow Mold Case	13.500 lb

Cat. No.	Description	Cat. No.	Description
CRW6N	3/8" Drive 60 Tooth Quick Release Teardrop Ratchet 9"	CDS47N	3/8" Drive 12 Point Standard Metric Socket 17mm
CDTA8N	3/8" Drive Extension 3"	CDS48N	3/8" Drive 12 Point Standard Metric Socket 18mm
CDTA9N	3/8" Drive Extension 6"	CDS49N	3/8" Drive 12 Point Standard Metric Socket 19mm
-	1/4" Hex to 1/4" Square Drive Adapter	CSP50N	3/8" Drive 6 Point 2-1/2" Spark Plug Socket 5/8"
-	3/8" Drive 12 Point Standard SAE Socket 3/16"	CSP2N	3/8" Drive 6 Point 2-1/2" Spark Plug Socket 13/16"
CDS23N	3/8" Drive 12 Point Standard SAE Socket 1/4"	CCW0	1/4" 12 Point Combination Wrench
CDS24N	3/8" Drive 12 Point Standard SAE Socket 5/16"	CCW1	5/16" 12 Point Combination Wrench
CDS25N	3/8" Drive 12 Point Standard SAE Socket 3/8"	CCW3	3/8" 12 Point Combination Wrench
CDS26N	3/8" Drive 12 Point Standard SAE Socket 7/16"	CCW4	7/16" 12 Point Combination Wrench
CDS27N	3/8" Drive 12 Point Standard SAE Socket 1/2"	CCW5	1/2" 12 Point Combination Wrench
CDS28N	3/8" Drive 12 Point Standard SAE Socket 9/16"	CCW6	9/16" 12 Point Combination Wrench
CDS29N	3/8" Drive 12 Point Standard SAE Socket 5/8"	CCW7	5/8" 12 Point Combination Wrench
CDS30N	3/8" Drive 12 Point Standard SAE Socket 11/16"	-	6mm 12 Point Combination Wrench
CDS31N	3/8" Drive 12 Point Standard SAE Socket 3/4"	CCW19	8mm 12 Point Combination Wrench
CDS32N	3/8" Drive 12 Point Standard SAE Socket 13/16"	CCW21	10mm 12 Point Combination Wrench
-	3/8" Drive 12 Point Standard Metric Socket 6mm	CCW23	12mm 12 Point Combination Wrench
CDS37N	3/8" Drive 12 Point Standard Metric Socket 7mm	CCW24	13mm 12 Point Combination Wrench
CDS38N	3/8" Drive 12 Point Standard Metric Socket 8mm	CCW25	14mm 12 Point Combination Wrench
CDS39N	3/8" Drive 12 Point Standard Metric Socket 9mm	CCW26	15mm 12 Point Combination Wrench
CDS40N	3/8" Drive 12 Point Standard Metric Socket 10mm	CRW25N	1/4" Drive Magnetic Bit Holding Screwdriver Handle
CDS41N	3/8" Drive 12 Point Standard Metric Socket 11mm	-	43 Assorted Insert Bits in Holder
CDS42N	3/8" Drive 12 Point Standard Metric Socket 12mm	-	8 SAE Nut Setter Bits
CDS43N	3/8" Drive 12 Point Standard Metric Socket 13mm	-	8 Metric Nut Setter Bits
CDS44N	3/8" Drive 12 Point Standard Metric Socket 14mm	-	12 Pc Short Arm SAE Hex Key Set with Caddy
CDS45N	3/8" Drive 12 Point Standard Metric Socket 15mm	-	12 Pc Short Arm Metric Hex Key Set with Caddy

30 Pc. 3/8" Drive 12 Point SAE/Metric Standard and Deep Mechanics Tool Set

- Contains a carefully selected assortment of hand tools needed for most industrial, mechanical and consumer applications
- 60-tooth ratchet requires only a 6-degree swing arc to turn a fastener
- Ratchets have a large, quick-release button for easy operation
- Sockets feature off-corner loading technology to virtually eliminate fastener rounding
- Manufactured from chrome alloy steel for better strength and longer tool life
- Includes blow mold case for storage and organization
- Meets or exceeds ANSI and ASME specifications



Cat. No.	Included Storage	Product Weight
CTK30SETN	Blow Mold Case	6.470 lb

Cat. No.	Description	Cat. No.	Description
CRW6N	3/8" Drive 60 Tooth Quick Release Teardrop Ratchet 9"	CDS44N	3/8" Drive 12 Point Standard Metric Socket 14mm
CDTA8N	3/8" Drive Extension 3"	CDS45N	3/8" Drive 12 Point Standard Metric Socket 15mm
CDTA9N	3/8" Drive Extension 6"	CDS47N	3/8" Drive 12 Point Standard Metric Socket 17mm
CDS24N	3/8" Drive 12 Point Standard SAE Socket 5/16"	CDS49N	3/8" Drive 12 Point Standard Metric Socket 19mm
CDS25N	3/8" Drive 12 Point Standard SAE Socket 3/8"	CDDS26N	3/8" Drive 6 Point Deep SAE Socket 7/16"
CDS26N	3/8" Drive 12 Point Standard SAE Socket 7/16"	CDDS27N	3/8" Drive 6 Point Deep SAE Socket 1/2"
CDS27N	3/8" Drive 12 Point Standard SAE Socket 1/2"	CDDS28N	3/8" Drive 6 Point Deep SAE Socket 9/16"
CDS28N	3/8" Drive 12 Point Standard SAE Socket 9/16"	CDDS29N	3/8" Drive 6 Point Deep SAE Socket 5/8"
CDS29N	3/8" Drive 12 Point Standard SAE Socket 5/8"	CDDS30N	3/8" Drive 6 Point Deep SAE Socket 11/16"
CDS30N	3/8" Drive 12 Point Standard SAE Socket 11/16"	CDDS42N	3/8" Drive 6 Point Deep Metric Socket 12mm
CDS31N	3/8" Drive 12 Point Standard SAE Socket 3/4"	CDDS43N	3/8" Drive 6 Point Deep Metric Socket 13mm
CDS39N	3/8" Drive 12 Point Standard Metric Socket 9mm	CDDS44N	3/8" Drive 6 Point Deep Metric Socket 14mm
CDS40N	3/8" Drive 12 Point Standard Metric Socket 10mm	CDDS46N	3/8" Drive 6 Point Deep Metric Socket 16mm
CDS42N	3/8" Drive 12 Point Standard Metric Socket 12mm	CDDS47N	3/8" Drive 6 Point Deep Metric Socket 17mm
CDS43N	3/8" Drive 12 Point Standard Metric Socket 13mm	CSPS2N	3/8" Drive 6 Point 2-1/2" Spark Plug Socket 13/16"

20 Pc. 3/8" Drive 12 Point SAE/Metric Mechanics Tool Set

- 60-tooth ratchet requires only a 6-degree swing arc to turn a fastener
- Teardrop ratchet head for improved access
- Quick release design allows for rapid socket removal
- Sockets feature off-corner loading technology to virtually eliminate fastener rounding
- Manufactured from chrome alloy steel for better strength and longer tool life
- Meets or exceeds ASME and ANSI specifications



Cat. No.	Included Storage	Product Weight
CSWS7N	None	2.730 lb

Cat. No.	Description	Cat. No.	Description
CRW6N	3/8" Drive 60 Tooth Quick Release Teardrop Ratchet 9"	CDS32N	3/8" Drive 12 Point Standard SAE Socket 13/16"

Cat. No.	Description	Cat. No.	Description
CDTA8N	3/8" Drive Extension 3"	CDS39N	3/8" Drive 12 Point Standard Metric Socket 9mm
CDS24N	3/8" Drive 12 Point Standard SAE Socket 5/16"	CDS40N	3/8" Drive 12 Point Standard Metric Socket 10mm
CDS25N	3/8" Drive 12 Point Standard SAE Socket 3/8"	CDS41N	3/8" Drive 12 Point Standard Metric Socket 11mm
CDS26N	3/8" Drive 12 Point Standard SAE Socket 7/16"	CDS42N	3/8" Drive 12 Point Standard Metric Socket 12mm
CDS27N	3/8" Drive 12 Point Standard SAE Socket 1/2"	CDS43N	3/8" Drive 12 Point Standard Metric Socket 13mm
CDS28N	3/8" Drive 12 Point Standard SAE Socket 9/16"	CDS44N	3/8" Drive 12 Point Standard Metric Socket 14mm
CDS29N	3/8" Drive 12 Point Standard SAE Socket 5/8"	CDS45N	3/8" Drive 12 Point Standard Metric Socket 15mm
CDS30N	3/8" Drive 12 Point Standard SAE Socket 11/16"	CDS47N	3/8" Drive 12 Point Standard Metric Socket 17mm
CDS31N	3/8" Drive 12 Point Standard SAE Socket 3/4"	CDS49N	3/8" Drive 12 Point Standard Metric Socket 19mm

10 Pc. 3/8" Drive 6 Point SAE Mechanics Tool Set

- 60-tooth ratchet requires only a 6-degree swing arc to turn a fastener
- Teardrop ratchet head for improved access
- Quick release design allows for rapid socket removal
- Sockets feature off-corner loading technology to virtually eliminate fastener rounding
- Manufactured from chrome alloy steel for better strength and longer tool life
- Includes blow mold case for storage and organization
- Meets or exceeds ASME and ANSI specifications



Cat. No.	Included Storage	Product Weight
CSWS38SAE10	Blow Mold Case	3.085 lb

Cat. No.	Description	Cat. No.	Description
CRW6N	3/8" Drive 60 Tooth Quick Release Teardrop Ratchet 9"	-	3/8" Drive 6 Point Standard SAE Socket 5/8"
-	3/8" Drive 6 Point Standard SAE Socket 3/8"	-	3/8" Drive 6 Point Standard SAE Socket 11/16"
-	3/8" Drive 6 Point Standard SAE Socket 7/16"	-	3/8" Drive 6 Point Standard SAE Socket 3/4"
-	3/8" Drive 6 Point Standard SAE Socket 1/2"	-	3/8" Drive 6 Point Standard SAE Socket 13/16"
-	3/8" Drive 6 Point Standard SAE Socket 9/16"	-	3/8" Drive 6 Point Standard SAE Socket 7/8"

10 Pc. 3/8" Drive 6 Point Metric Mechanics Tool Set

- 60-tooth ratchet requires only a 6-degree swing arc to turn a fastener
- Teardrop ratchet head for improved access
- Quick release design allows for rapid socket removal
- Sockets feature off-corner loading technology to virtually eliminate fastener rounding
- Manufactured from chrome alloy steel for better strength and longer tool life
- Includes blow mold case for storage and organization
- Meets or exceeds ASME and ANSI specifications



Cat. No.	Included Storage	Product Weight
CSWS38MM10	Blow Mold Case	0.820 lb

Cat. No.	Description	Cat. No.	Description
CRW6N	3/8" Drive 60 Tooth Quick Release Teardrop Ratchet 9"	CDS44N	3/8" Drive 12 Point Standard Metric Socket 14mm
CDS40N	3/8" Drive 12 Point Standard Metric Socket 10mm	CDS45N	3/8" Drive 12 Point Standard Metric Socket 15mm
CDS41N	3/8" Drive 12 Point Standard Metric Socket 11mm	CDS46N	3/8" Drive 12 Point Standard Metric Socket 16mm
CDS42N	3/8" Drive 12 Point Standard Metric Socket 12mm	CDS47N	3/8" Drive 12 Point Standard Metric Socket 17mm
CDS43N	3/8" Drive 12 Point Standard Metric Socket 13mm	CDS48N	3/8" Drive 12 Point Standard Metric Socket 18mm

3/8" DRIVE

9 Pc. 3/8" Drive 12 Point Standard SAE Socket Set

- Manufactured from chrome alloy steel for better strength and longer tool life
- Off-corner loading technology to virtually eliminate fastener rounding
- Size markings stamped on socket for quick size identification
- Nickel chrome plated for durability
- Meets or exceeds ASME specifications



Cat. No.	Included Storage	Product Weight
CSAS4N	Socket Rail	0.830 lb

Cat. No.	Description	Cat. No.	Description
CDS23N	3/8" Drive 12 Point Standard SAE Socket 1/4"	CDS28N	3/8" Drive 12 Point Standard SAE Socket 9/16"
CDS24N	3/8" Drive 12 Point Standard SAE Socket 5/16"	CDS29N	3/8" Drive 12 Point Standard SAE Socket 5/8"
CDS25N	3/8" Drive 12 Point Standard SAE Socket 3/8"	CDS30N	3/8" Drive 12 Point Standard SAE Socket 11/16"
CDS26N	3/8" Drive 12 Point Standard SAE Socket 7/16"	CDS31N	3/8" Drive 12 Point Standard SAE Socket 3/4"
CDS27N	3/8" Drive 12 Point Standard SAE Socket 1/2"		

3/8" DRIVE

11 Pc. 3/8" Drive 12 Point SAE Mechanics Tool Set

- 60-tooth ratchet requires only a 6-degree swing arc to turn a fastener
- Teardrop ratchet head for improved access
- Quick release design allows for rapid socket removal
- Sockets feature off-corner loading technology to virtually eliminate fastener rounding
- Manufactured from chrome alloy steel for better strength and longer tool life
- Includes blow mold case for storage and organization
- Meets or exceeds ASME and ANSI specifications



Cat. No.	Included Storage	Product Weight
CSWS6N	Blow Mold Case	2.650 lb

Cat. No.	Description	Cat. No.	Description
CRW6N	3/8" Drive 60 Tooth Quick Release Teardrop Ratchet 9"	CDS29N	3/8" Drive 12 Point Standard SAE Socket 5/8"
CDTA9N	3/8" Drive Extension 6"	CDS30N	3/8" Drive 12 Point Standard SAE Socket 11/16"
CDS25N	3/8" Drive 12 Point Standard SAE Socket 3/8"	CDS31N	3/8" Drive 12 Point Standard SAE Socket 3/4"
CDS26N	3/8" Drive 12 Point Standard SAE Socket 7/16"	CDS32N	3/8" Drive 12 Point Standard SAE Socket 13/16"
CDS27N	3/8" Drive 12 Point Standard SAE Socket 1/2"	CDS33N	3/8" Drive 12 Point Standard SAE Socket 7/8"
CDS28N	3/8" Drive 12 Point Standard SAE Socket 9/16"		

9 Pc. 3/8" Drive 12 Point Standard Metric Socket Set

- Manufactured from chrome alloy steel for better strength and longer tool life
- Off-corner loading technology to virtually eliminate fastener rounding
- Size markings stamped on socket for quick size identification
- Nickel chrome plated for durability
- Meets or exceeds ASME specifications



Cat. No.	Included Storage	Product Weight
CSAS5N	Socket Rail	0.840 lb

Cat. No.	Description	Cat. No.	Description
CDS39N	3/8" Drive 12 Point Standard Metric Socket 9mm	CDS44N	3/8" Drive 12 Point Standard Metric Socket 14mm
CDS40N	3/8" Drive 12 Point Standard Metric Socket 10mm	CDS45N	3/8" Drive 12 Point Standard Metric Socket 15mm
CDS41N	3/8" Drive 12 Point Standard Metric Socket 11mm	CDS47N	3/8" Drive 12 Point Standard Metric Socket 17mm
CDS42N	3/8" Drive 12 Point Standard Metric Socket 12mm	CDS49N	3/8" Drive 12 Point Standard Metric Socket 19mm
CDS43N	3/8" Drive 12 Point Standard Metric Socket 13mm		

9 Pc. 3/8" Drive 6 Point Deep SAE Socket Set

- Manufactured from chrome alloy steel for better strength and longer tool life
- Off-corner loading technology to virtually eliminate fastener rounding
- Size markings stamped on socket for quick size identification
- Nickel chrome plated for durability
- Meets or exceeds ASME specifications



Cat. No.	Included Storage	Product Weight
CSAS6N	Socket Rail	1.730 lb

Cat. No.	Description	Cat. No.	Description
CDDS23N	3/8" Drive 6 Point Deep SAE Socket 1/4"	CDDS28N	3/8" Drive 6 Point Deep SAE Socket 9/16"
CDDS24N	3/8" Drive 6 Point Deep SAE Socket 5/16"	CDDS29N	3/8" Drive 6 Point Deep SAE Socket 5/8"
CDDS25N	3/8" Drive 6 Point Deep SAE Socket 3/8"	CDDS30N	3/8" Drive 6 Point Deep SAE Socket 11/16"
CDDS26N	3/8" Drive 6 Point Deep SAE Socket 7/16"	CDDS31N	3/8" Drive 6 Point Deep SAE Socket 3/4"
CDDS27N	3/8" Drive 6 Point Deep SAE Socket 1/2"		

3/8" DRIVE

7 Pc. 3/8" Drive SAE Hex Bit Socket Set

- Manufactured from chrome alloy steel for better strength and longer tool life
- Size markings stamped on base for quick size identification
- Insert bits made of S2 steel for strength and durability
- Nickel chrome plated base for durability
- Meets or exceeds ASME specifications



Cat. No.	Included Storage	Product Weight
CBSS0N	None	.73 lb

Cat. No.	Description	Cat. No.	Description
-	3/8" Drive Hex Bit SAE Socket 1/8"	-	3/8" Drive Hex Bit SAE Socket 1/4"
-	3/8" Drive Hex Bit SAE Socket 5/32"	-	3/8" Drive Hex Bit SAE Socket 5/16"
-	3/8" Drive Hex Bit SAE Socket 3/16"	-	3/8" Drive Hex Bit SAE Socket 3/8"
-	3/8" Drive Hex Bit SAE Socket 7/32"		

3/8" DRIVE

9 Pc. 3/8" Drive 6 Point Deep Metric Socket Set

- Manufactured from chrome alloy steel for better strength and longer tool life
- Off-corner loading technology to virtually eliminate fastener rounding
- Size markings stamped on socket for quick size identification
- Nickel chrome plated for durability
- Meets or exceeds ASME specifications



Cat. No.	Included Storage	Product Weight
CSAS7N	Socket Rail	1.720 lb

Cat. No.	Description	Cat. No.	Description
CDDS39N	3/8" Drive 6 Point Deep Metric Socket 9mm	CDDS44N	3/8" Drive 6 Point Deep Metric Socket 14mm
CDDS40N	3/8" Drive 6 Point Deep Metric Socket 10mm	CDDS45N	3/8" Drive 6 Point Deep Metric Socket 15mm
CDDS41N	3/8" Drive 6 Point Deep Metric Socket 11mm	CDDS47N	3/8" Drive 6 Point Deep Metric Socket 17mm
CDDS42N	3/8" Drive 6 Point Deep Metric Socket 12mm	CDDS49N	3/8" Drive 6 Point Deep Metric Socket 19mm
CDDS43N	3/8" Drive 6 Point Deep Metric Socket 13mm		

7 Pc. 3/8" Drive Metric Hex Bit Socket Set

- Manufactured from chrome alloy steel for better strength and longer tool life
- Size markings stamped on base for quick size identification
- Insert bits made of S2 steel for strength and durability
- Nickel chrome plated base for durability
- Meets or exceeds ASME specifications



Cat. No.	Included Storage	Product Weight
CBSS1N	None	0.700 lb

Cat. No.	Description	Cat. No.	Description
-	3/8" Drive Hex Bit Metric Socket 3mm	CHBS10N	3/8" Drive Hex Bit Metric Socket 7mm
CHBS7N	3/8" Drive Hex Bit Metric Socket 4mm	CHBS11N	3/8" Drive Hex Bit Metric Socket 8mm
CHBS8N	3/8" Drive Hex Bit Metric Socket 5mm	CHBS12N	3/8" Drive Hex Bit Metric Socket 10mm
CHBS9N	3/8" Drive Hex Bit Metric Socket 6mm		

3/8" Drive Quick Release 60 Tooth Teardrop Ratchet

- 60-tooth ratchet turns fasteners with a 6° swing arc
- Quick-release design allows for rapid socket removal
- Teardrop head for improved access
- Manufactured from chrome alloy steel for better strength and longer tool life
- Bright, full polish chrome finish easily wipes clean and resists corrosion
- Meets or exceeds ASME specifications



Cat. No.	Overall Length	Head Width	Head Thickness	Tooth Count	Product Weight
CRW6N	9 in	1.281 in	.625 in	60	1.010 lb

3/8" Drive Quick Release 72 Tooth Teardrop Ratchet

- 72-tooth ratchet turns fasteners with a 5° swing arc
- Quick-release design allows for rapid socket removal
- Teardrop head for improved access
- Manufactured from chrome vanadium alloy steel for increased strength and longer tool life
- Bright, full polish chrome finish easily wipes clean and resists corrosion
- Meets or exceeds ASME specifications



Cat. No.	Overall Length	Head Width	Tooth Count	Product Weight
CRW6	7.95 in	1.42 in	72	0.81 lb

3/8" Drive Quick Release 72 Tooth Stubby Teardrop Ratchet

- 72-tooth ratchet turns fasteners with a 5° swing arc
- Stubby handle length for when clearance is limited
- Quick-release design allows for rapid socket removal
- Teardrop head for improved access
- Manufactured from chrome alloy steel for better strength and longer tool life
- Bright, full polish chrome finish easily wipes clean and resists corrosion
- Meets or exceeds ASME specifications



Cat. No.	Overall Length	Head Width	Tooth Count	Product Weight
CRW11	4.57 in	1.42 in	72	0.59 lb

3/8" Drive Quick Release 72 Tooth Dual Material Ratchet

- 72-tooth ratchet turns fasteners with a 5° swing arc
- Quick-release design allows for rapid socket removal
- Teardrop head for improved access
- Manufactured from chrome vanadium alloy steel for better strength and longer tool life
- Dual material comfort grip handle
- Nickel chrome plated for long-lasting protection
- Meets or exceeds ASME specifications



Cat. No.	Overall Length	Head Width	Tooth Count	Product Weight
CRW7	8.46 in	1.42 in	72	0.88 lb

3/8" Drive Quick Release 72 Tooth Flex Head Teardrop Ratchet

- 72-tooth ratchet turns fasteners with a 5° swing arc
- Flexible head provides access for hard to reach fasteners
- Quick-release design allows for rapid socket removal
- Teardrop head for improved access
- Manufactured from chrome vanadium alloy steel for better strength and longer tool life
- Bright, full polish chrome finish easily wipes clean and resists corrosion
- Meets or exceeds ASME specifications



Cat. No.	Overall Length	Head Width	Tooth Count	Product Weight
CRW10	11.34 in	1.38 in	72	1.09 lb

3/8" Drive Flex Handle / Breaker Bar

- Flexible head for better access
- Long handle for greater torque
- Manufactured from chrome alloy steel for better strength and longer tool life
- Bright, full polish chrome finish easily wipes clean and resists corrosion
- Meets or exceeds ASME specifications



Cat. No.	Overall Length	Product Weight
CRW15N	10 in	0.770 lb

3 Pc. 3/8" Drive Extension Set

- Manufactured from chrome alloy steel for better strength and longer tool life
- Bright, full polish chrome finish easily wipes clean and resists corrosion
- Ball detent for secure socket retention
- Meets or exceeds ASME specifications



Cat. No.	Included Storage	Product Weight
CDTA15N	None	1.040 lb

Cat. No.	Description
CDTA8N	3/8" Drive Extension 3"
CDTA9N	3/8" Drive Extension 6"
CDTA10N	3/8" Drive Extension 10"

3/8" DRIVE

3/8" Drive Extensions

- Manufactured from chrome alloy steel for better strength and longer tool life
- Bright, full polish chrome finish easily wipes clean and resists corrosion
- Ball detent for secure socket retention
- Meets or exceeds ASME specifications



Cat. No.	Overall Length	Wobble	Product Weight
CDTA8N	3 in	No	0.180 lb
CDTA9N	6 in	No	0.340 lb
CDTA10N	10 in	No	0.540 lb

3/8" Drive Adapters

- Manufactured from chrome alloy steel for better strength and longer tool life
- Bright, full polish chrome finish easily wipes clean and resists corrosion
- Ball detent for secure socket retention
- Meets or exceeds ASME specifications



Cat. No.	Overall Length	Female Drive Size	Male Drive Size	Product Weight
CDTA1N	1 in	3/8"	1/4"	0.060 lb
CDTA2N	1.4 in	3/8"	1/2"	0.110 lb

3/8" Drive Universal Joint

- Universal joint gives improved access to hard to reach fasteners
- Manufactured from chrome alloy steel for better strength and longer tool life
- Bright, full polish chrome finish easily wipes clean and resists corrosion
- Ball detent for secure socket retention
- Meets or exceeds ASME specifications



Cat. No.	Overall Length	Product Weight
CDTA17N	2 in	0.150 lb

3/8" Drive 12 Point Standard Sockets

- Manufactured from chrome alloy steel for better strength and longer tool life
- Off-corner loading technology to virtually eliminate fastener rounding
- Size markings stamped on socket for quick size identification
- Nickel chrome plated for durability
- Meets or exceeds ASME specifications

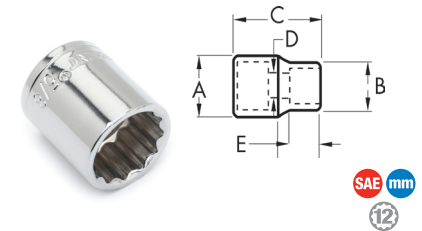

Cat. No.	SAE/Metric	Fastener Size	Dim. A: Drive End	Dim. B: Wrench End	Dim. C: Overall Length	Dim. D: Bolt Clearance	Dim. E: Wrench Depth	Product Weight
CDS23N	SAE	1/4 in	0.65 in	0.35 in	0.95 in	0.15 in	0.30 in	0.070 lb
CDS24N	SAE	5/16 in	0.65 in	0.43 in	0.95 in	0.22 in	0.30 in	0.070 lb
CDS25N	SAE	3/8 in	0.65 in	0.48 in	0.95 in	0.28 in	0.30 in	0.070 lb
CDS26N	SAE	7/16 in	0.65 in	0.58 in	0.95 in	0.35 in	0.30 in	0.070 lb
CDS27N	SAE	1/2 in	0.65 in	0.65 in	0.95 in	0.36 in	0.30 in	0.080 lb
CDS28N	SAE	9/16 in	0.74 in	0.74 in	0.98 in	0.496 in	0.53 in	0.100 lb
CDS29N	SAE	5/8 in	0.78 in	0.78 in	0.98 in	0.562 in	0.53 in	0.110 lb
CDS30N	SAE	11/16 in	0.88 in	0.88 in	1.02 in	0.562 in	0.53 in	0.130 lb
CDS31N	SAE	3/4 in	1 in	1 in	1.13 in	0.657 in	0.65 in	0.150 lb
CDS32N	SAE	13/16 in	1.2 in	1.2 in	1.2 in	0.681 in	0.65 in	0.190 lb
CDS33N	SAE	7/8 in	1.3 in	1.3 in	1.2 in	0.751 in	0.65 in	0.210 lb
CDS37N	Metric	7 mm	0.65 in	0.43 in	0.94 in	0.20 in	0.28 in	0.070 lb
CDS38N	Metric	8 mm	0.65 in	0.49 in	0.94 in	0.27 in	0.28 in	0.070 lb
CDS39N	Metric	9 mm	0.65 in	0.53 in	0.94 in	0.30 in	0.28 in	0.070 lb
CDS40N	Metric	10 mm	0.65 in	0.58 in	0.94 in	0.34 in	0.28 in	0.070 lb
CDS41N	Metric	11 mm	0.65 in	0.65 in	0.94 in	0.34 in	0.28 in	0.070 lb
CDS42N	Metric	12 mm	0.68 in	0.68 in	1 in	0.283 in	0.53 in	0.070 lb
CDS43N	Metric	13 mm	0.74 in	0.74 in	1 in	0.275 in	0.53 in	0.080 lb
CDS44N	Metric	14 mm	0.78 in	0.78 in	1 in	0.496 in	0.53 in	0.100 lb
CDS45N	Metric	15 mm	0.82 in	0.82 in	1 in	0.496 in	0.63 in	0.120 lb
CDS46N	Metric	16 mm	0.87 in	0.87 in	1 in	0.566 in	0.63 in	0.110 lb
CDS47N	Metric	17 mm	0.93 in	0.93 in	1 in	0.566 in	0.63 in	0.140 lb
CDS48N	Metric	18 mm	0.95 in	0.95 in	1 in	0.606 in	0.63 in	0.140 lb
CDS49N	Metric	19 mm	1 in	1 in	1.11 in	0.657 in	0.70 in	0.150 lb
CDS51N	Metric	21 mm	1.2 in	1.2 in	1.2 in	0.688 in	0.70 in	0.190 lb
CDS52N	Metric	22 mm	1.3 in	1.3 in	1.2 in	0.732 in	0.70 in	0.210 lb

3/8" DRIVE

3/8" Drive 6 Point Deep Sockets

- Manufactured from chrome alloy steel for better strength and longer tool life
- Off-corner loading technology to virtually eliminate fastener rounding
- Size markings stamped on socket for quick size identification
- Nickel chrome plated for durability
- Meets or exceeds ASME specifications

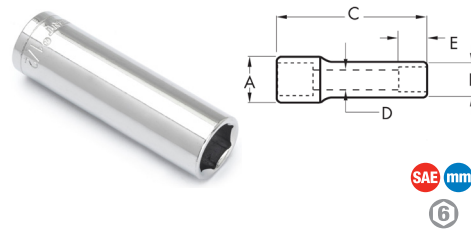

Cat. No.	SAE/Metric	Fastener Size	Dim. A: Drive End	Dim. B: Wrench End	Dim. C: Overall Length	Dim. D: Bolt Clearance	Dim. E: Wrench Depth	Product Weight
CDDS23N	SAE	1/4 in	0.67 in	0.45 in	2.5 in	0.15 in	0.35 in	0.140 lb
CDDS24N	SAE	5/16 in	0.67 in	0.48 in	2.5 in	0.22 in	0.68 in	0.130 lb
CDDS25N	SAE	3/8 in	0.67 in	0.58 in	2.5 in	0.28 in	0.68 in	0.150 lb
CDDS26N	SAE	7/16 in	0.66 in	0.66 in	2.5 in	0.30 in	0.68 in	0.140 lb
CDDS27N	SAE	1/2 in	0.73 in	0.73 in	2.5 in	0.30 in	1.13 in	0.190 lb
CDDS28N	SAE	9/16 in	0.77 in	0.77 in	2.5 in	0.30 in	1.13 in	0.200 lb
CDDS29N	SAE	5/8 in	0.86 in	0.86 in	2.5 in	0.30 in	1.13 in	0.240 lb
CDDS30N	SAE	11/16 in	0.92 in	0.92 in	2.5 in	0.30 in	1.13 in	0.280 lb
CDDS31N	SAE	3/4 in	1 in	1 in	2.5 in	0.30 in	1.13 in	0.320 lb
CDDS32N	SAE	13/16 in	1.1 in	1.1 in	2.5 in	0.30 in	1.13 in	0.360 lb
CDDS33N	SAE	7/8 in	1.2 in	1.2 in	2.5 in	0.30 in	1.13 in	0.090 lb
CDDS38N	Metric	8 mm	0.65 in	0.65 in	2.5 in	0.15 in	0.43 in	0.130 lb
CDDS39N	Metric	9 mm	0.65 in	0.65 in	2.5 in	0.22 in	0.43 in	0.140 lb
CDDS40N	Metric	10 mm	0.65 in	0.65 in	2.5 in	0.30 in	0.43 in	0.140 lb
CDDS41N	Metric	11 mm	0.66 in	0.66 in	2.5 in	0.30 in	0.71 in	0.140 lb
CDDS42N	Metric	12 mm	0.73 in	0.73 in	2.5 in	0.30 in	0.71 in	0.170 lb
CDDS43N	Metric	13 mm	0.73 in	0.73 in	2.5 in	0.30 in	1.12 in	0.180 lb
CDDS44N	Metric	14 mm	0.79 in	0.79 in	2.5 in	0.30 in	1.12 in	0.190 lb
CDDS45N	Metric	15 mm	0.81 in	0.81 in	2.5 in	0.30 in	1.12 in	0.210 lb
CDDS46N	Metric	16 mm	0.93 in	0.93 in	2.5 in	0.30 in	1.25 in	0.230 lb
CDDS47N	Metric	17 mm	0.94 in	0.94 in	2.5 in	0.30 in	1.25 in	0.280 lb
CDDS48N	Metric	18 mm	1 in	1 in	2.5 in	0.30 in	1.25 in	0.290 lb
CDDS49N	Metric	19 mm	1 in	1 in	2.5 in	0.30 in	1.25 in	0.310 lb

Cat. No.	SAE/Metric	Fastener Size	Dim. A: Drive End	Dim. B: Nose Diameter	Dim. C: Overall Length	Dim. D: Bit Length	Dim. E: Wrench Depth	Product Weight
CHBS1N	SAE	5/32 in	0.70 in	0.25 in	1.9 in	1.35 in	.52 in	0.090 lb
CHBS2N	SAE	3/16 in	0.70 in	0.25 in	1.9 in	1.35 in	.52 in	0.090 lb
CHBS3N	SAE	7/32 in	0.70 in	0.25 in	1.9 in	1.35 in	.52 in	0.090 lb
CHBS4N	SAE	1/4 in	0.70 in	0.31 in	1.9 in	1.35 in	.52 in	0.100 lb
CHBS5N	SAE	5/16 in	0.70 in	0.31 in	1.9 in	1.35 in	.52 in	0.110 lb
CHBS6N	SAE	3/8 in	0.70 in	0.31 in	1.9 in	1.35 in	.52 in	0.130 lb
CHBS7N	Metric	4 mm	0.70 in	0.25 in	1.9 in	1.35 in	.52 in	0.090 lb
CHBS8N	Metric	5 mm	0.70 in	0.25 in	1.9 in	1.35 in	.52 in	0.090 lb
CHBS9N	Metric	6 mm	0.70 in	0.25 in	1.9 in	1.35 in	.52 in	0.100 lb
CHBS10N	Metric	7 mm	0.70 in	0.25 in	1.9 in	1.35 in	.52 in	0.110 lb
CHBS11N	Metric	8 mm	0.70 in	0.31 in	1.9 in	1.35 in	.52 in	0.110 lb
CHBS12N	Metric	10 mm	0.70 in	0.31 in	1.9 in	1.35 in	.52 in	0.130 lb

3/8" Drive Torx® Bit Sockets

- Manufactured from chrome alloy steel for better strength and longer tool life
- Size markings stamped on base for quick size identification
- Insert bits made of S2 steel for strength and durability
- Nickel chrome plated base for durability
- Meets or exceeds ASME specifications

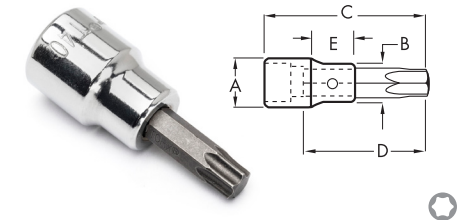

Cat. No.	Fastener Size	Dim. A: Drive End	Dim. B: Nose Diameter	Dim. C: Overall Length	Dim. D: Bit Length	Dim. E: Wrench Depth	Product Weight
CDTS6N	T40	0.70 in	0.25 in	1.9 in	1.35 in	0.52 in	0.090 lb
CDTS7N	T45	0.70 in	0.31 in	1.9 in	1.35 in	0.52 in	0.110 lb
CDTS8N	T47	0.70 in	0.31 in	1.9 in	1.35 in	0.52 in	0.120 lb
CDTS9N	T50	0.70 in	0.31 in	1.9 in	1.35 in	0.52 in	0.110 lb
CDTS10N	T55	0.70 in	0.31 in	1.9 in	1.35 in	0.52 in	0.120 lb
CDTS11N	T60	0.70 in	0.31 in	1.9 in	1.35 in	0.52 in	0.130 lb

3/8" Drive Hex Bit Sockets

- Manufactured from chrome alloy steel for better strength and longer tool life
- Size markings stamped on base for quick size identification
- Insert bits made of S2 steel for strength and durability
- Nickel chrome plated base for durability
- Meets or exceeds ASME specifications

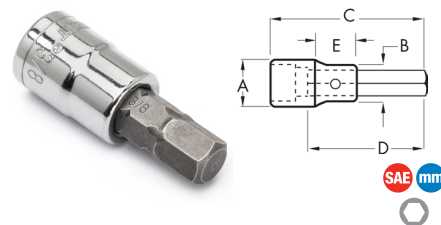

Cat. No.	SAE/Metric	Fastener Size	Dim. A: Drive End	Dim. B: Nose Diameter	Dim. C: Overall Length	Dim. D: Bit Length	Dim. E: Wrench Depth	Product Weight
CHBS0N	SAE	1/8 in	0.70 in	0.25 in	1.9 in	1.35 in	.52 in	0.090 lb

3/8" DRIVE

3/8" DRIVE

3/8" Drive 6 Point Spark Plug Sockets

- Use with 3/8" square drive hand tool
- Manufactured from chrome alloy steel for better strength and longer tool life
- Off-corner loading technology to virtually eliminate fastener rounding
- Nickel chrome plated for durability
- Meets or exceeds ASME specifications



Cat. No.	SAE/Metric	Fastener Size	Dim. A: Drive End	Dim. B: Wrench End	Dim. C: Overall Length	Dim. D: Bolt Clearance	Dim. E: Wrench Depth	Product Weight
CSPSON	SAE	5/8 in	.87 in	0.87 in	2.5 in	0.18 in	0.75 in	0.230 lb
CSPS1N	SAE	3/4 in	1.01 in	1.01 in	2.63 in	0.10 in	0.75 in	0.280 lb
CSPS2N	SAE	13/16 in	1.07 in	1.07 in	2.73 in	0.10 in	0.75 in	0.310 lb

3/8" DRIVE

3/8" Drive Socket Rail

- Perfect to store, organize, and easily find all your sockets
- Drilled at end for easy attachment to wall, workbench, or drawer
- Red color for easy identification
- Includes 14 socket clips



Cat. No.	Drive Size	Color	Overall Length	Number of Clips	Product Weight
CSR1	3/8 in	Red	17.5 in	14	0.44 lb

12 Pc. 1/2" Drive 12 Point SAE Mechanics Tool Set with Blow Mold Case

- 60-tooth ratchet requires only a 6-degree swing arc to turn a fastener
- Teardrop ratchet head for improved access
- Quick release design allows for rapid socket removal
- Manufactured from chrome alloy steel for better strength and longer tool life
- Sockets feature off-corner loading technology to virtually eliminate fastener rounding
- Includes blow mold case for storage and organization
- Meets or exceeds ASME and ANSI specifications



Cat. No.	Included Storage	Product Weight
CSWS11N	Blow Mold Case	4.580 lb

Cat. No.	Description	Cat. No.	Description
CRW12N	1/2" Drive 60 Tooth Quick Release Teardrop Ratchet 10-1/2"	CDS57N	1/2" Drive 12 Point Standard SAE Socket 11/16"
CDTA11N	1/2" Drive Extension 3"	CDS58N	1/2" Drive 12 Point Standard SAE Socket 3/4"
CDS53N	1/2" Drive 12 Point Standard SAE Socket 7/16"	CDS59N	1/2" Drive 12 Point Standard SAE Socket 13/16"
CDS54N	1/2" Drive 12 Point Standard SAE Socket 1/2"	CDS60N	1/2" Drive 12 Point Standard SAE Socket 7/8"

Cat. No.	Description	Cat. No.	Description
CDS55N	1/2" Drive 12 Point Standard SAE Socket 9/16"	CDS61N	1/2" Drive 12 Point Standard SAE Socket 15/16"
CDS56N	1/2" Drive 12 Point Standard SAE Socket 5/8"	CDS62N	1/2" Drive 12 Point Standard SAE Socket 1"

12 Pc. 1/2" Drive 12 Point SAE Mechanics Tool Set

- 60-tooth ratchet requires only a 6-degree swing arc to turn a fastener
- Teardrop ratchet head for improved access
- Quick release design allows for rapid socket removal
- Manufactured from chrome alloy steel for better strength and longer tool life
- Sockets feature off-corner loading technology to virtually eliminate fastener rounding
- Meets or exceeds ASME and ANSI specifications



1/2" DRIVE

Cat. No.	Included Storage	Product Weight
CSWS12N	Socket Rail	3.695 lb



Cat. No.	Description	Cat. No.	Description
CRW12N	1/2" Drive 60 Tooth Quick Release Teardrop Ratchet 10-1/2"	CDS57N	1/2" Drive 12 Point Standard SAE Socket 11/16"
CDTA11N	1/2" Drive Extension 3"	CDS58N	1/2" Drive 12 Point Standard SAE Socket 3/4"
CDS53N	1/2" Drive 12 Point Standard SAE Socket 7/16"	CDS59N	1/2" Drive 12 Point Standard SAE Socket 13/16"
CDS54N	1/2" Drive 12 Point Standard SAE Socket 1/2"	CDS60N	1/2" Drive 12 Point Standard SAE Socket 7/8"
CDS55N	1/2" Drive 12 Point Standard SAE Socket 9/16"	CDS61N	1/2" Drive 12 Point Standard SAE Socket 15/16"
CDS56N	1/2" Drive 12 Point Standard SAE Socket 5/8"	CDS62N	1/2" Drive 12 Point Standard SAE Socket 1"

8 Pc. 1/2" Drive 12 Point Standard SAE Socket Set

- Manufactured from chrome alloy steel for better strength and longer tool life
- Off-corner loading technology to virtually eliminate fastener rounding
- Size markings stamped on socket for quick size identification
- Nickel chrome plated for durability
- Meets or exceeds ASME specifications



Cat. No.	Included Storage	Product Weight
CSAS0N	Socket Rail	1.530 lb



Cat. No.	Description	Cat. No.	Description
CDS54N	1/2" Drive 12 Point Standard SAE Socket 1/2"	CDS58N	1/2" Drive 12 Point Standard SAE Socket 3/4"
CDS55N	1/2" Drive 12 Point Standard SAE Socket 9/16"	CDS59N	1/2" Drive 12 Point Standard SAE Socket 13/16"
CDS56N	1/2" Drive 12 Point Standard SAE Socket 5/8"	CDS60N	1/2" Drive 12 Point Standard SAE Socket 7/8"
CDS57N	1/2" Drive 12 Point Standard SAE Socket 11/16"	CDS61N	1/2" Drive 12 Point Standard SAE Socket 15/16"

8 Pc. 1/2" Drive 12 Point Standard Metric Socket Set

- Manufactured from chrome alloy steel for better strength and longer tool life
- Off-corner loading technology to virtually eliminate fastener rounding
- Size markings stamped on socket for quick size identification
- Nickel chrome plated for durability
- Meets or exceeds ASME specifications



Cat. No.	Included Storage	Product Weight
CSAS1N	Socket Rail	1.320 lb



Cat. No.	Description	Cat. No.	Description
CDS72N	1/2" Drive 12 Point Standard Metric Socket 12mm	CDS77N	1/2" Drive 12 Point Standard Metric Socket 17mm
CDS73N	1/2" Drive 12 Point Standard Metric Socket 13mm	CDS78N	1/2" Drive 12 Point Standard Metric Socket 18mm
CDS74N	1/2" Drive 12 Point Standard Metric Socket 14mm	CDS79N	1/2" Drive 12 Point Standard Metric Socket 19mm
CDS75N	1/2" Drive 12 Point Standard Metric Socket 15mm	CDS81N	1/2" Drive 12 Point Standard Metric Socket 21mm

1/2" DRIVE

8 Pc. 1/2" Drive 6 Point Deep Metric Socket Set

- Manufactured from chrome alloy steel for better strength and longer tool life
- Off-corner loading technology to virtually eliminate fastener rounding
- Size markings stamped on socket for quick size identification
- Nickel chrome plated for durability
- Meets or exceeds ASME specifications



Cat. No.	Included Storage	Product Weight
CSAS3N	Socket Rail	2.620 lb



Cat. No.	Description	Cat. No.	Description
CDDS71N	1/2" Drive 6 Point Deep Metric Socket 12mm	CDDS76N	1/2" Drive 6 Point Deep Metric Socket 17mm
CDDS72N	1/2" Drive 6 Point Deep Metric Socket 13mm	CDDS77N	1/2" Drive 6 Point Deep Metric Socket 18mm
CDDS73N	1/2" Drive 6 Point Deep Metric Socket 14mm	CDDS78N	1/2" Drive 6 Point Deep Metric Socket 19mm
CDDS74N	1/2" Drive 6 Point Deep Metric Socket 15mm	CDDS80N	1/2" Drive 6 Point Deep Metric Socket 21mm

1/2" DRIVE

8 Pc. 1/2" Drive 6 Point Deep SAE Socket Set

- Manufactured from chrome alloy steel for better strength and longer tool life
- Off-corner loading technology to virtually eliminate fastener rounding
- Size markings stamped on socket for quick size identification
- Nickel chrome plated for durability
- Meets or exceeds ASME specifications



Cat. No.	Included Storage	Product Weight
CSAS2N	Socket Rail	3.020 lb



Cat. No.	Description	Cat. No.	Description
CDDS56N	1/2" Drive 6 Point Deep SAE Socket 1/2"	CDDS60N	1/2" Drive 6 Point Deep SAE Socket 3/4"
CDDS57N	1/2" Drive 6 Point Deep SAE Socket 9/16"	CDDS61N	1/2" Drive 6 Point Deep SAE Socket 13/16"
CDDS58N	1/2" Drive 6 Point Deep SAE Socket 5/8"	CDDS62N	1/2" Drive 6 Point Deep SAE Socket 7/8"
CDDS59N	1/2" Drive 6 Point Deep SAE Socket 11/16"	CDDS63N	1/2" Drive 6 Point Deep SAE Socket 15/16"

1/2" Drive Quick Release 60 Tooth Teardrop Ratchet

- 60-tooth ratchet turns fasteners with a 6° swing arc
- Quick-release design allows for rapid socket removal
- Teardrop head for improved access
- Manufactured from chrome alloy steel for better strength and longer tool life
- Bright, full polish chrome finish easily wipes clean and resists corrosion
- Meets or exceeds ASME specifications



Cat. No.	Overall Length	Head Width	Head Thickness	Tooth Count	Product Weight
CRW12N	10.5 in	1.67 in	.77 in	60	1.690 lb

1/2" Drive Quick Release 72 Tooth Teardrop Ratchets

- Teardrop head for improved access
- 72 tooth ratchet turns fasteners with a 5° swing arc
- Reversible
- Manufactured from chrome vanadium alloy steel for better strength and longer tool life
- Meets or exceeds ANSI specifications
- Quick release design allows for rapid socket removal



Cat. No.	Overall Length	Head Width	Tooth Count	Product Weight
CRW12	12.28 in	2.4 in	72	1.50 lb

1/2" Drive Quick Release 72 Tooth Dual Material Ratchet

- 72-tooth ratchet turns fasteners with a 5° swing arc
- Quick-release design allows for rapid socket removal
- Teardrop head for improved access
- Manufactured from chrome vanadium alloy steel for better strength and longer tool life
- Dual material comfort grip handle
- Nickel chrome plated for long-lasting protection
- Meets or exceeds ASME specifications



Cat. No.	Overall Length	Head Width	Tooth Count	Product Weight
CRW13	10.83 in	1.61 in	72	1.54 lb

1/2" Drive Quick Release 72 Tooth Flex Head Teardrop Ratchet

- 72-tooth ratchet turns fasteners with a 5° swing arc
- Flexible head provides access for hard to reach fasteners
- Quick-release design allows for rapid socket removal
- Teardrop head for improved access
- Manufactured from chrome vanadium alloy steel for better strength and longer tool life
- Bright, full polish chrome finish easily wipes clean and resists corrosion
- Meets or exceeds ASME specifications



Cat. No.	Overall Length	Head Width	Tooth Count	Product Weight
CRW14	12.25 in	1.65 in	72	1.77 lb

1/2" Drive Quick Release 72 Tooth Extendable Teardrop Ratchet

- 72-tooth ratchet turns fasteners with a 5° swing arc
- Extends from 12" to 17.5"
- Quick-release design allows for rapid socket removal
- Teardrop head for improved access
- Manufactured from chrome alloy steel for better strength and longer tool life
- Bright, full polish chrome finish easily wipes clean and resists corrosion
- Meets or exceeds ASME specifications



Cat. No.	Cont. Length	Ext. Length	Head Width	Head Thickness	Tooth Count	Product Weight
CRW12EXT	12 in	17.5 in	1.875 in	.812 in	72	1.890 lb

1/2" Drive Flex Handle/Breaker Bar

- Flexible head for better access
- Long handle for greater torque
- Manufactured from chrome alloy steel for better strength and longer tool life
- Bright, full polish chrome finish easily wipes clean and resists corrosion
- Meets or exceeds ASME specifications



Cat. No.	Overall Length	Product Weight
CRW16N	18 in	1.810 lb

1/2" Drive Extensions

- Manufactured from chrome alloy steel for better strength and longer tool life
- Bright, full polish chrome finish easily wipes clean and resists corrosion
- Ball detent for secure socket retention
- Meets or exceeds ASME specifications



Cat. No.	Overall Length	Wobble	Product Weight
CDTA11N	3 in	No	0.290 lb
CDTA12N	5 in	No	0.460 lb
CDTA13N	10 in	No	0.870 lb

1/2" Drive Universal Joint

- Universal joint gives improved access to hard to reach fasteners
- Manufactured from chrome alloy steel for better strength and longer tool life
- Bright, full polish chrome finish easily wipes clean and resists corrosion
- Ball detent for secure socket retention
- Meets or exceeds ASME specifications



Cat. No.	Overall Length	Product Weight
CDTA18N	2.83 in	0.340 lb

1/2" Drive Adapters

- Manufactured from chrome alloy steel for better strength and longer tool life
- Bright, full polish chrome finish easily wipes clean and resists corrosion
- Ball detent for secure socket retention
- Meets or exceeds ASME specifications



Cat. No.	Overall Length	Female Drive Size	Male Drive Size	Product Weight
CDTA3N	1.47 in	1/2"	3/8"	0.120 lb
CDTA4N	1.9 in	1/2"	3/4"	0.030 lb

1/2" DRIVE

1/2" Drive 12 Point Standard Sockets

- Manufactured from chrome alloy steel for better strength and longer tool life
- Off-corner loading technology to virtually eliminate fastener rounding
- Size markings stamped on socket for quick size identification
- Nickel chrome plated for durability
- Meets or exceeds ASME specifications

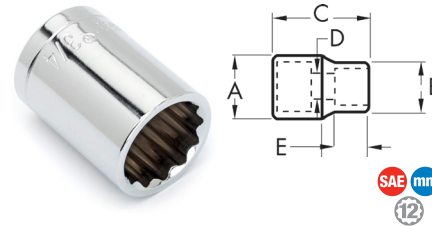

Cat. No.	SAE/Metric	Fastener Size	Dim. A: Drive End	Dim. B: Wrench End	Dim. C: Overall Length	Dim. D: Bolt Clearance	Dim. E: Wrench Depth	Product Weight
CDS53N	SAE	7/16 in	0.85 in	0.76 in	1.5 in	0.38 in	0.36 in	0.130 lb
CDS54N	SAE	1/2 in	0.85 in	0.76 in	1.5 in	0.38 in	0.36 in	0.140 lb
CDS55N	SAE	9/16 in	0.85 in	0.84 in	1.5 in	0.38 in	0.36 in	0.130 lb
CDS56N	SAE	5/8 in	0.91 in	0.91 in	1.5 in	0.48 in	0.54 in	0.140 lb
CDS57N	SAE	11/16 in	0.99 in	0.99 in	1.5 in	0.48 in	0.54 in	0.170 lb
CDS58N	SAE	3/4 in	1.06 in	1.06 in	1.5 in	0.661 in	0.80 in	0.190 lb
CDS59N	SAE	13/16 in	1.09 in	1.09 in	1.5 in	0.685 in	0.80 in	0.220 lb
CDS60N	SAE	7/8 in	1.17 in	1.17 in	1.5 in	0.75 in	0.80 in	0.260 lb
CDS61N	SAE	15/16 in	1.27 in	1.27 in	1.5 in	0.755 in	0.80 in	0.290 lb
CDS62N	SAE	1 in	1.30 in	1.3 in	1.5 in	0.826 in	0.80 in	0.360 lb
CDS63N	SAE	1-1/16 in	1.43 in	1.43 in	1.5 in	0.944 in	0.80 in	0.420 lb
CDS64N	SAE	1-1/8 in	1.49 in	1.49 in	1.5 in	0.988 in	0.80 in	0.460 lb
CDS66N	SAE	1-1/4 in	1.65 in	1.65 in	1.5 in	1.129 in	0.80 in	0.580 lb
CDS72N	Metric	12 mm	0.85 in	0.73 in	1.5 in	0.30 in	0.38 in	0.120 lb
CDS73N	Metric	13 mm	0.85 in	0.76 in	1.5 in	0.30 in	0.38 in	0.130 lb
CDS74N	Metric	14 mm	0.85 in	0.83 in	1.5 in	0.37 in	0.38 in	0.130 lb
CDS75N	Metric	15 mm	0.87 in	0.87 in	1.5 in	0.41 in	0.53 in	0.140 lb
CDS76N	Metric	16 mm	0.94 in	0.94 in	1.5 in	0.41 in	0.53 in	0.140 lb
CDS77N	Metric	17 mm	0.94 in	0.94 in	1.5 in	0.43 in	0.53 in	0.170 lb
CDS78N	Metric	18 mm	1.02 in	1.02 in	1.5 in	0.43 in	0.55 in	0.210 lb
CDS79N	Metric	19 mm	1.06 in	1.06 in	1.5 in	0.661 in	0.80 in	0.180 lb
CDS80N	Metric	20 mm	1.1 in	1.10 in	1.5 in	0.685 in	0.80 in	0.230 lb
CDS81N	Metric	21 mm	1.17 in	1.17 in	1.5 in	0.696 in	0.80 in	0.220 lb

Cat. No.	SAE/Metric	Fastener Size	Dim. A: Drive End	Dim. B: Wrench End	Dim. C: Overall Length	Dim. D: Bolt Clearance	Dim. E: Wrench Depth	Product Weight
CDS82N	Metric	22 mm	1.17 in	1.17 in	1.5 in	0.740 in	0.80 in	0.250 lb
CDS84N	Metric	24 mm	1.25 in	1.25 in	1.5 in	0.822 in	0.80 in	0.290 lb
CDS87N	Metric	27 mm	1.41 in	1.41 in	1.5 in	0.937 in	0.80 in	0.400 lb

1/2" Drive 6 Point Deep Sockets

- Manufactured from chrome alloy steel for better strength and longer tool life
- Off-corner loading technology to virtually eliminate fastener rounding
- Size markings stamped on socket for quick size identification
- Nickel chrome plated for durability
- Meets or exceeds ASME specifications

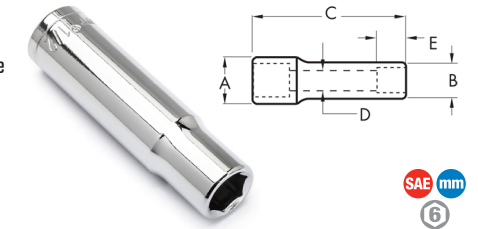

Cat. No.	SAE/Metric	Fastener Size	Dim. A: Drive End	Dim. B: Wrench End	Dim. C: Overall Length	Dim. D: Bolt Clearance	Dim. E: Wrench Depth	Product Weight
CDDS55N	SAE	7/16 in	0.85 in	0.75 in	3.27 in	0.38 in	0.48 in	0.270 lb
CDDS56N	SAE	1/2 in	0.89 in	0.77 in	3.27 in	0.38 in	0.48 in	0.290 lb
CDDS57N	SAE	9/16 in	0.89 in	0.85 in	3.27 in	0.38 in	0.48 in	0.260 lb
CDDS58N	SAE	5/8 in	0.90 in	0.9 in	3.27 in	0.48 in	1.4 in	0.260 lb
CDDS59N	SAE	11/16 in	0.98 in	0.98 in	3.27 in	0.48 in	1.4 in	0.310 lb
CDDS60N	SAE	3/4 in	1.07 in	1.07 in	3.27 in	1.338 in	1.4 in	0.370 lb
CDDS61N	SAE	13/16 in	1.09 in	1.09 in	3.27 in	1.338 in	1.4 in	0.430 lb
CDDS62N	SAE	7/8 in	1.17 in	1.17 in	3.27 in	1.338 in	1.4 in	0.510 lb
CDDS63N	SAE	15/16 in	1.25 in	1.25 in	3.27 in	1.338 in	1.4 in	0.580 lb
CDDS64N	SAE	1 in	1.30 in	1.3 in	3.27 in	1.338 in	1.4 in	0.660 lb
CDDS65N	SAE	1-1/16 in	1.40 in	1.4 in	3.27 in	1.338 in	1.4 in	0.750 lb
CDDS66N	SAE	1-1/8 in	1.48 in	1.48 in	3.27 in	1.338 in	1.4 in	0.860 lb
CDDS67N	SAE	1-1/4 in	1.65 in	1.65 in	3.27 in	1.338 in	1.4 in	1.050 lb
CDDS71N	Metric	12 mm	0.88 in	0.73 in	3.27 in	0.30 in	0.50 in	0.260 lb
CDDS72N	Metric	13 mm	0.88 in	0.77 in	3.27 in	0.30 in	0.50 in	0.280 lb
CDDS73N	Metric	14 mm	0.88 in	0.84 in	3.27 in	0.37 in	0.50 in	0.250 lb
CDDS74N	Metric	15 mm	0.86 in	0.86 in	3.27 in	0.41 in	1.4 in	0.280 lb
CDDS75N	Metric	16 mm	0.93 in	0.93 in	3.27 in	0.41 in	1.4 in	0.260 lb
CDDS76N	Metric	17 mm	0.95 in	0.95 in	3.27 in	0.43 in	1.4 in	0.320 lb
CDDS77N	Metric	18 mm	1.02 in	1.02 in	3.27 in	0.43 in	1.4 in	0.400 lb
CDDS78N	Metric	19 mm	1.06 in	1.06 in	3.27 in	1.338 in	1.4 in	0.370 lb
CDDS80N	Metric	21 mm	1.09 in	1.09 in	3.27 in	1.338 in	1.4 in	0.430 lb

1/2" Drive 6 Point Magnetic Spark Plug Sockets

- Use with 1/2" square drive hand tool
- Manufactured from chrome alloy steel for better strength and longer tool life
- Off-corner loading technology to virtually eliminate fastener rounding
- Magnetic insert holds plug for removal and installation
- Nickel chrome plated for durability
- Meets or exceeds ASME specifications



Cat. No.	SAE/Metric	Fastener Size	Dim. A: Drive End	Dim. B: Wrench End	Dim. C: Overall Length	Dim. D: Bolt Clearance	Dim. E: Wrench Depth	Product Weight
CSPS3N	SAE	5/8 in	.87 in	0.87 in	2.5 in	0.18 in	0.75 in	0.220 lb
CSPS4N	SAE	13/16 in	1.07 in	1.07 in	2.73 in	0.10 in	0.75 in	0.340 lb

1/2" DRIVE

1/2" Drive Socket Rail

- Perfect to store, organize, and easily find all your sockets
- Drilled at end for easy attachment to wall, workbench, or drawer
- Yellow color for easy identification
- Includes 14 socket clips



Cat. No.	Drive Size	Color	Overall Length	Number of Clips	Product Weight
CSR2	1/2 in	Yellow	17.5 in	14	0.46 lb

21 Pc. 3/4" Drive 12 Point SAE Standard Mechanics Tool Set

- Contains a carefully selected assortment of tools to handle most large mechanical applications
- Heavy-duty, 45-tooth ratchet with quick release socket retention button to hold sockets securely
- Sockets feature off-corner loading technology to reduce fastener rounding
- Manufactured from chrome alloy steel for better strength and longer tool life
- Includes blow mold case for storage and organization
- Meets or exceeds ANSI and ASME specifications



Cat. No.	Included Storage	Product Weight
CTK21SAEN	Blow Mold Case	26.500 lb

Cat. No.	Description	Cat. No.	Description
CRW19N	3/4" Drive 45 Tooth Quick Release Round Head Ratchet 20"	CDS97N	3/4" Drive 12 Point Standard SAE Socket 1-1/4"
CRW23N	3/4" Drive Full Polish Flex Handle 19"	CDS98N	3/4" Drive 12 Point Standard SAE Socket 1-5/16"
CRW20N	3/4" Drive Extension 4"	CDS99N	3/4" Drive 12 Point Standard SAE Socket 1-3/8"

Cat. No.	Description	Cat. No.	Description
CRW21N	3/4" Drive Extension 8"	CDS100N	3/4" Drive 12 Point Standard SAE Socket 1-7/16"
CRW22N	3/4" Drive Extension 16"	CDS101N	3/4" Drive 12 Point Standard SAE Socket 1-1/2"
CDS91N	3/4" Drive 12 Point Standard SAE Socket 7/8"	CDS102N	3/4" Drive 12 Point Standard SAE Socket 1-5/8"
CDS92N	3/4" Drive 12 Point Standard SAE Socket 15/16"	CDS104N	3/4" Drive 12 Point Standard SAE Socket 1-3/4"
CDS93N	3/4" Drive 12 Point Standard SAE Socket 1"	CDS105N	3/4" Drive 12 Point Standard SAE Socket 1-13/16"
CDS94N	3/4" Drive 12 Point Standard SAE Socket 1-1/16"	CDS106N	3/4" Drive 12 Point Standard SAE Socket 1-7/8"
CDS95N	3/4" Drive 12 Point Standard SAE Socket 1-1/8"	CDS107N	3/4" Drive 12 Point Standard SAE Socket 2"
-	3/4" Drive 12 Point Standard SAE Socket 1-3/16"		

3/4" DRIVE

14 Pc. 3/4" Drive 12 Point SAE Standard Mechanics Tool Set

- Contains a carefully selected assortment of hand tools needed for most industrial, mechanical and consumer applications
- Heavy-duty, 45-tooth ratchet with quick release socket retention button to hold sockets securely
- Sockets feature off-corner loading technology to reduce fastener rounding
- Manufactured from chrome alloy steel for better strength and longer tool life
- Includes blow mold case for storage and organization
- Meets or exceeds ANSI and ASME specifications



Cat. No.	Included Storage	Product Weight
CTK14SAEN	Blow Mold Case	35.500 lb



Cat. No.	Description	Cat. No.	Description
CRW19N	3/4" Drive 45 Tooth Quick Release Round Head Ratchet 20"	CDS95N	3/4" Drive 12 Point Standard SAE Socket 1-1/8"
CRW23N	3/4" Drive Full Polish Flex Handle 19"	CDS97N	3/4" Drive 12 Point Standard SAE Socket 1-1/4"
CRW20N	3/4" Drive Extension 4"	CDS100N	3/4" Drive 12 Point Standard SAE Socket 1-7/16"
CRW21N	3/4" Drive Extension 8"	CDS101N	3/4" Drive 12 Point Standard SAE Socket 1-1/2"
CDS91N	3/4" Drive 12 Point Standard SAE Socket 7/8"	CDS102N	3/4" Drive 12 Point Standard SAE Socket 1-5/8"
CDS92N	3/4" Drive 12 Point Standard SAE Socket 15/16"	CDS104N	3/4" Drive 12 Point Standard SAE Socket 1-3/4"
CDS93N	3/4" Drive 12 Point Standard SAE Socket 1"	CDS107N	3/4" Drive 12 Point Standard SAE Socket 2"

3/4" Drive Quick Release 45 Tooth Round

- 45-tooth ratchet turns fasteners with a 8° swing arc
- 20" long handle for improved reach, leverage and torque
- Quick-release design allows for rapid socket removal
- Round-shaped head
- Features a knurled grip, providing a non-slip surface
- Manufactured from chrome alloy steel for better strength and longer tool life
- Bright, full polish chrome finish easily wipes clean and resists corrosion
- Meets or exceeds ASME specifications



Cat. No.	Overall Length	Head Width	Head Thickness	Tooth Count	Product Weight
CRW19N	20 in	2.7 in	1.7 in	45	5.290 lb

3/4" Drive Flex Handle / Breaker Bar

- Flexible head for better access
- Long handle for greater torque
- Manufactured from chrome alloy steel for better strength and longer tool life
- Bright, full polish chrome finish easily wipes clean and resists corrosion
- Meets or exceeds ASME specifications



Cat. No.	Overall Length	Product Weight
CRW23N	19 in	4.230 lb

3/4" Drive Sliding T-Handle

- Sliding tang for variable torque
- Long handle for greater torque
- Manufactured from chrome alloy steel for better strength and longer tool life
- Bright, full polish chrome finish easily wipes clean and resists corrosion
- Meets or exceeds ASME specifications



Cat. No.	Overall Length	Product Weight
CRW24N	18 in	3.110 lb

3/4" Drive Extensions

- Manufactured from chrome alloy steel for better strength and longer tool life
- Bright, full polish chrome finish easily wipes clean and resists corrosion
- Ball detent for secure socket retention
- Meets or exceeds ASME specifications



Cat. No.	Overall Length	Wobble	Product Weight
CRW20N	4 in	No	1.050 lb
CRW21N	8 in	No	1.620 lb
CRW22N	16 in	No	2.990 lb

3/4" Drive Adapters

- Manufactured from chrome alloy steel for better strength and longer tool life
- Bright, full polish chrome finish easily wipes clean and resists corrosion
- Ball detent for secure socket retention
- Meets or exceeds ASME specifications



Cat. No.	Overall Length	Female Drive Size	Male Drive Size	Product Weight
CDTA5N	1.9 in	3/4"	1/2"	0.450 lb

3/4" Drive 12 Point Standard Sockets

- Manufactured from chrome alloy steel for better strength and longer tool life
- Off-corner loading technology to virtually eliminate fastener rounding
- Size markings stamped on socket for quick size identification
- Nickel chrome plated for durability
- Meets or exceeds ASME specifications

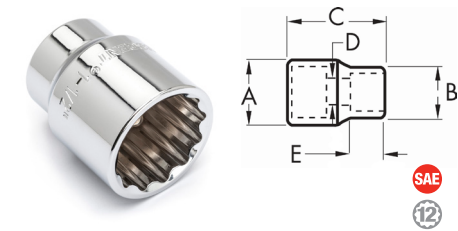

Cat. No.	SAE/Metric	Fastener Size	Dim. A: Drive End	Dim. B: Wrench End	Dim. C: Overall Length	Dim. D: Bolt Clearance	Dim. E: Wrench Depth	Product Weight
CDS91N	SAE	7/8 in	1.41 in	1.29 in	1.97 in	0.62 in	0.70 in	0.490 lb
CDS92N	SAE	15/16 in	1.41 in	1.39 in	1.97 in	0.66 in	0.70 in	0.500 lb
CDS93N	SAE	1 in	1.41 in	1.41 in	1.97 in	0.590 in	1 in	0.440 lb
CDS94N	SAE	1-1/16 in	1.50 in	1.50 in	2 in	0.944 in	1 in	0.490 lb
CDS95N	SAE	1-1/8 in	1.56 in	1.56 in	2.06 in	0.988 in	1 in	0.530 lb
CDS97N	SAE	1-1/4 in	1.73 in	1.73 in	2.18 in	0.751 in	1 in	0.710 lb
CDS98N	SAE	1-5/16 in	1.80 in	1.80 in	2.18 in	0.767 in	1 in	0.500 lb
CDS99N	SAE	1-3/8 in	1.86 in	1.86 in	2.18 in	0.783 in	1 in	0.830 lb
CDS100N	SAE	1-7/16 in	1.96 in	1.96 in	2.3 in	0.854 in	1.14 in	1.000 lb

Continued on next page

3/4" Drive 12 Point Standard Sockets Continued from previous page

Cat. No.	SAE/Metric	Fastener Size	Dim. A: Drive End	Dim. B: Wrench End	Dim. C: Overall Length	Dim. D: Bolt Clearance	Dim. E: Wrench Depth	Product Weight
CDS101N	SAE	1-1/2 in	2.04 in	2.04 in	2.45 in	0.854 in	1.22 in	1.070 lb
CDS102N	SAE	1-5/8 in	2.20 in	2.2 in	2.6 in	1.003 in	1.36 in	1.410 lb
CDS103N	SAE	1-11/16 in	2.30 in	2.3 in	2.67 in	1.003 in	1.45 in	1.320 lb
CDS104N	SAE	1-3/4 in	2.36 in	2.36 in	2.73 in	1.094 in	1.58 in	1.500 lb
CDS105N	SAE	1-13/16 in	2.45 in	2.45 in	2.84 in	1.129 in	1.60 in	1.520 lb
CDS106N	SAE	1-7/8 in	2.55 in	2.55 in	2.93 in	1.129 in	1.60 in	1.790 lb
CDS107N	SAE	2 in	2.68 in	2.68 in	3 in	1.220 in	1.70 in	1.870 lb

8 Pc. 1/2" Drive 6 Point Standard Impact Metric Socket Set

- Manufactured from chrome molybdenum alloy steel [CR-MO] for better strength and longer tool life
- Off-corner loading technology to virtually eliminate fastener rounding
- Size markings stamped for quick size identification
- Black phosphate finish for corrosion resistance
- Meets or exceeds ASME specifications



Cat. No.	Included Storage	Product Weight
CIMS1N	Socket Rail	1.830 lb

Cat. No.	Description	Cat. No.	Description
CIMS12N	1/2" Drive 6 Point Standard Impact Metric Socket 12mm	CIMS16N	1/2" Drive 6 Point Standard Impact Metric Socket 17mm
CIMS13N	1/2" Drive 6 Point Standard Impact Metric Socket 13mm	CIMS17N	1/2" Drive 6 Point Standard Impact Metric Socket 18mm
CIMS14N	1/2" Drive 6 Point Standard Impact Metric Socket 14mm	CIMS18N	1/2" Drive 6 Point Standard Impact Metric Socket 19mm
CIMS15N	1/2" Drive 6 Point Standard Impact Metric Socket 15mm	CIMS19N	1/2" Drive 6 Point Standard Impact Metric Socket 21mm

8 Pc. 1/2" Drive 6 Point Standard Impact SAE Socket Set

- Manufactured from chrome molybdenum alloy steel [CR-MO] for better strength and longer tool life
- Off-corner loading technology to virtually eliminate fastener rounding
- Size markings stamped for quick size identification
- Black phosphate finish for corrosion resistance
- Meets or exceeds ASME specifications



Cat. No.	Included Storage	Product Weight
CIMSON	Socket Rail	1.850 lb

Cat. No.	Description	Cat. No.	Description
CIMS4N	1/2" Drive 6 Point Standard Impact SAE Socket 7/16"	CIMS8N	1/2" Drive 6 Point Standard Impact SAE Socket 11/16"
CIMS5N	1/2" Drive 6 Point Standard Impact SAE Socket 1/2"	CIMS9N	1/2" Drive 6 Point Standard Impact SAE Socket 3/4"
CIMS6N	1/2" Drive 6 Point Standard Impact SAE Socket 9/16"	CIMS10N	1/2" Drive 6 Point Standard Impact SAE Socket 13/16"
CIMS7N	1/2" Drive 6 Point Standard Impact SAE Socket 5/8"	CIMS11N	1/2" Drive 6 Point Standard Impact SAE Socket 7/8"

8 Pc. 1/2" Drive 6 Point Deep Impact SAE Socket Set

- Manufactured from chrome molybdenum alloy steel [CR-MO] for better strength and longer tool life
- Off-corner loading technology to virtually eliminate fastener rounding
- Size markings stamped for quick size identification
- Black oxide finish for corrosion resistance
- Meets or exceeds ASME specifications



Cat. No.	Included Storage	Product Weight
CIMS2N	Socket Rail	3.780 lb

Cat. No.	Description	Cat. No.	Description
CIMS20N	1/2" Drive 6 Point Deep Impact SAE Socket 7/16"	CIMS24N	1/2" Drive 6 Point Deep Impact SAE Socket 11/16"
CIMS21N	1/2" Drive 6 Point Deep Impact SAE Socket 1/2"	CIMS25N	1/2" Drive 6 Point Deep Impact SAE Socket 3/4"
CIMS22N	1/2" Drive 6 Point Deep Impact SAE Socket 9/16"	CIMS26N	1/2" Drive 6 Point Deep Impact SAE Socket 13/16"
CIMS23N	1/2" Drive 6 Point Deep Impact SAE Socket 5/8"	CIMS27N	1/2" Drive 6 Point Deep Impact SAE Socket 7/8"

IMPACT

IMPACT

8 Pc. 1/2" Drive 6 Point Deep Impact Metric Socket Set

- Manufactured from chrome molybdenum alloy steel [CR-MO] for better strength and longer tool life
- Off-corner loading technology to virtually eliminate fastener rounding
- Size markings stamped for quick size identification
- Black phosphate finish for corrosion resistance
- Meets or exceeds ASME specifications



mm

6

Cat. No.	Included Storage	Product Weight
CIMS3N	Socket Rail	3.650 lb

Cat. No.	Description	Cat. No.	Description
CIMS28N	1/2" Drive 6 Point Deep Impact Metric Socket 12mm	CIMS32N	1/2" Drive 6 Point Deep Impact Metric Socket 17mm
CIMS29N	1/2" Drive 6 Point Deep Impact Metric Socket 13mm	CIMS33N	1/2" Drive 6 Point Deep Impact Metric Socket 18mm
CIMS30N	1/2" Drive 6 Point Deep Impact Metric Socket 14mm	CIMS34N	1/2" Drive 6 Point Deep Impact Metric Socket 19mm
CIMS31N	1/2" Drive 6 Point Deep Impact Metric Socket 15mm	CIMS35N	1/2" Drive 6 Point Deep Impact Metric Socket 21mm

7 Pc. 1/2" Drive Hex Bit Impact SAE Socket Set

- Manufactured from chrome molybdenum alloy steel [CR-MO] for better strength and longer tool life
- Insert bits made of S2 steel for strength and durability
- Black oxide finish for corrosion resistance
- Meets or exceeds ASME specifications



SAE

6

Cat. No.	Included Storage	Product Weight
CIMBS11N	None	2.305 lb

Cat. No.	Description	Cat. No.	Description
-	1/2" Drive Impact Hex Bit SAE Socket 3/8"	-	1/2" Drive Impact Hex Bit SAE Socket 5/8"
-	1/2" Drive Impact Hex Bit SAE Socket 7/16"	-	1/2" Drive Impact Hex Bit SAE Socket 11/16"
-	1/2" Drive Impact Hex Bit SAE Socket 1/2"	-	1/2" Drive Impact Hex Bit SAE Socket 3/4"
-	1/2" Drive Impact Hex Bit SAE Socket 9/16"		

1/2" Drive Impact Extension

- Manufactured from chrome molybdenum alloy steel [CR-MO] for better strength and longer tool life
- Black oxide finish for corrosion resistance
- Ball detent for secure socket retention
- Meets or exceeds ASME specifications



Cat. No.	Overall Length	Wobble	Product Weight
CIMSA3N	5 in	No	0.530 lb

1/2" Drive Impact Adapters

- Manufactured from chrome molybdenum alloy steel [CR-MO] for better strength and longer tool life
- Black oxide finish for corrosion resistance
- Ball detent for secure socket retention
- Meets or exceeds ASME specifications



Cat. No.	Female Drive Size	Male Drive Size	Product Weight
CIMSA2N	1/2"	3/8"	0.170 lb
CIMSA1N	1/2"	3/4"	0.290 lb

1/2" Drive Impact Universal Joint

- Universal joint gives improved access to hard to reach fasteners
- Manufactured from chrome molybdenum alloy steel [CR-MO] for better strength and longer tool life
- Black oxide finish for corrosion resistance
- Ball detent for secure socket retention
- Meets or exceeds ASME specifications



Cat. No.	Product Weight
CIMSA4N	0.310 lb

1/2" Drive 6 Point Standard Impact Sockets

- Manufactured from chrome molybdenum alloy steel [CR-MO] for better strength and longer tool life
- Off-corner loading technology to virtually eliminate fastener rounding
- Size markings stamped for quick size identification
- Black phosphate finish for corrosion resistance
- Meets or exceeds ASME specifications

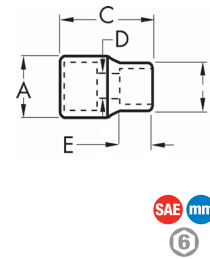

Cat. No.	SAE/Metric	Fastener Size	Dim. A: Drive End	Dim. B: Wrench End	Dim. C: Overall Length	Dim. D: Bolt Clearance	Dim. E: Wrench Depth	Product Weight
CIMS4N	SAE	7/16 in	0.98 in	0.66 in	1.62 in	0.33 in	0.5 in	0.200 lb
CIMS5N	SAE	1/2 in	0.98 in	0.72 in	1.62 in	0.33 in	0.5 in	0.200 lb
CIMS6N	SAE	9/16 in	0.98 in	0.98 in	1.62 in	0.43 in	0.5 in	0.200 lb
CIMS7N	SAE	5/8 in	0.98 in	0.98 in	1.62 in	0.43 in	0.5 in	0.190 lb
CIMS8N	SAE	11/16 in	1 in	1 in	1.62 in	0.5 in	0.5 in	0.230 lb
CIMS9N	SAE	3/4 in	1.17 in	1.17 in	1.62 in	0.49 in	0.75 in	0.250 lb
CIMS10N	SAE	13/16 in	1.25 in	1.25 in	1.62 in	0.49 in	0.75 in	0.290 lb
CIMS11N	SAE	7/8 in	1.25 in	1.25 in	1.62 in	0.49 in	0.75 in	0.330 lb
CIMS12N	Metric	12 mm	0.98 in	0.70 in	1.5 in	0.35 in	0.5 in	0.200 lb
CIMS13N	Metric	13 mm	0.98 in	0.70 in	1.5 in	0.35 in	0.54 in	0.190 lb
CIMS14N	Metric	14 mm	0.98 in	0.77 in	1.5 in	0.45 in	0.54 in	0.200 lb
CIMS15N	Metric	15 mm	0.98 in	0.98 in	1.5 in	0.45 in	0.54 in	0.200 lb
CIMS16N	Metric	17 mm	1 in	1 in	1.5 in	0.45 in	0.54 in	0.220 lb
CIMS17N	Metric	18 mm	1.1 in	1.1 in	1.5 in	0.49 in	0.54 in	0.280 lb
CIMS18N	Metric	19 mm	1.17 in	1.17 in	1.5 in	0.49 in	0.75 in	0.250 lb
CIMS19N	Metric	21 mm	1.25 in	1.25 in	1.5 in	0.49 in	0.75 in	0.280 lb

IMPACT

1/2" Drive 6 Point Deep Impact Sockets

- Manufactured from chrome molybdenum alloy steel [CR-MO] for better strength and longer tool life
- Off-corner loading technology to virtually eliminate fastener rounding
- Size markings stamped for quick size identification
- Black phosphate finish for corrosion resistance
- Meets or exceeds ASME specifications

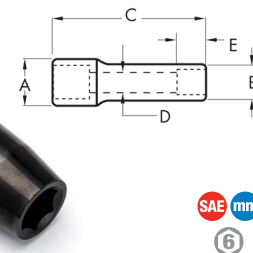

Cat. No.	SAE/Metric	Fastener Size	Dim. A: Drive End	Dim. B: Wrench End	Dim. C: Overall Length	Dim. D: Bolt Clearance	Dim. E: Wrench Depth	Product Weight
CIMS20N	SAE	7/16 in	0.95 in	0.73 in	3.17 in	0.36 in	0.50 in	0.420 lb
CIMS21N	SAE	1/2 in	0.95 in	0.73 in	3.17 in	0.36 in	0.50 in	0.410 lb
CIMS22N	SAE	9/16 in	0.95 in	0.73 in	3.17 in	0.36 in	1.15 in	0.410 lb
CIMS23N	SAE	5/8 in	0.95 in	0.95 in	3.17 in	0.36 in	1.15 in	0.370 lb
CIMS24N	SAE	11/16 in	0.95 in	0.95 in	3.17 in	0.45 in	1.15 in	0.440 lb
CIMS25N	SAE	3/4 in	1.1 in	1.1 in	3.17 in	0.45 in	1.15 in	0.490 lb
CIMS26N	SAE	13/16 in	1.18 in	1.18 in	3.17 in	0.45 in	1.15 in	0.570 lb

Cat. No.	SAE/Metric	Fastener Size	Dim. A: Drive End	Dim. B: Wrench End	Dim. C: Overall Length	Dim. D: Bolt Clearance	Dim. E: Wrench Depth	Product Weight
CIMS27N	SAE	7/8 in	1.26 in	1.26 in	3.17 in	0.45 in	1.15 in	0.660 lb
CIMS28N	Metric	12 mm	0.95 in	0.73 in	3.21 in	0.36 in	0.50 in	0.410 lb
CIMS29N	Metric	13 mm	0.95 in	0.73 in	3.21 in	0.36 in	0.50 in	0.410 lb
CIMS30N	Metric	14 mm	0.95 in	0.73 in	3.21 in	0.36 in	1.15 in	0.410 lb
CIMS31N	Metric	15 mm	0.95 in	0.95 in	3.21 in	0.36 in	1.15 in	0.370 lb
CIMS32N	Metric	17 mm	0.95 in	0.95 in	3.21 in	0.45 in	1.15 in	0.450 lb
CIMS33N	Metric	18 mm	1.1 in	1.1 in	3.21 in	0.45 in	1.15 in	0.530 lb
CIMS34N	Metric	19 mm	1.18 in	1.18 in	3.21 in	0.45 in	1.15 in	0.500 lb
CIMS35N	Metric	21 mm	1.26 in	1.26 in	3.21 in	0.45 in	1.15 in	0.560 lb

9 Pc. X10 12 Point SAE Long Pattern Combination Wrench Set

- Incredible strength and corrosion resistance from specially formulated and heat-treated chrome alloy steel
- Off-corner loading technology on the box-end reduces fastener rounding
- 15 degree box end offset for additional knuckle clearance
- Open end has anti-slip feature for better gripping power on fasteners
- Long pattern design increases both reach and leverage
- Large markings for quick size identification
- Black manganese phosphate finish for extreme corrosion resistance and smooth-ground surfaces to reduce friction
- Includes rack for storage and organization
- Meets or exceeds ASME and ANSI specifications



Cat. No.	Included Storage	Product Weight
CCWS9BS	Wrench Rack	2.380 lb

Cat. No.	Description	Cat. No.	Description
-	1/4" 12 Point Long Pattern Combination Wrench	-	9/16" 12 Point Long Pattern Combination Wrench
-	5/16" 12 Point Long Pattern Combination Wrench	-	5/8" 12 Point Long Pattern Combination Wrench
-	3/8" 12 Point Long Pattern Combination Wrench	-	11/16" 12 Point Long Pattern Combination Wrench
-	7/16" 12 Point Long Pattern Combination Wrench	-	3/4" 12 Point Long Pattern Combination Wrench
-	1/2" 12 Point Long Pattern Combination Wrench		

COMBINATION
WRENCHES

9 Pc. X10 12 Point Metric Long Pattern Combination Wrench Set

- Incredible strength and corrosion resistance from specially formulated and heat-treated chrome alloy steel
- Off-corner loading technology on the box-end reduces fastener rounding
- 15 degree box end offset for additional knuckle clearance
- Open end has anti-slip feature for better gripping power on fasteners
- Long pattern design increases both reach and leverage
- Large markings for quick size identification
- Black manganese phosphate finish for extreme corrosion resistance and smooth-ground surfaces to reduce friction
- Includes rack for storage and organization
- Meets or exceeds ASME and ANSI specifications



Cat. No.	Included Storage	Product Weight
CCWS9BM	Wrench Rack	2.475 lb

Cat. No.	Description	Cat. No.	Description
-	8mm 12 Point Long Pattern Combination Wrench	-	14mm 12 Point Long Pattern Combination Wrench
-	10mm 12 Point Long Pattern Combination Wrench	-	15mm 12 Point Long Pattern Combination Wrench
-	11mm 12 Point Long Pattern Combination Wrench	-	17mm 12 Point Long Pattern Combination Wrench
-	12mm 12 Point Long Pattern Combination Wrench	-	19mm 12 Point Long Pattern Combination Wrench
-	13mm 12 Point Long Pattern Combination Wrench		

15 Pc. 12 Point Metric Combination Wrench Set

- Incredible strength and corrosion resistance from specially formulated and heat-treated chrome alloy steel
- Off-corner loading design on box end provides better grip and reduces fastener rounding
- Sizes stamped on both sides of each wrench for easy identification
- Bright, full polish chrome finish easily wipes clean and resists corrosion
- Includes tool roll for storage and organization
- Meets or exceeds ASME and ANSI specifications



Cat. No.	Included Storage	Product Weight
CCWS5	Tool Roll	5.69 lb

Cat. No.	Description	Cat. No.	Description
CCW18	7mm 12 Point Combination Wrench	CCW26	15mm 12 Point Combination Wrench
CCW19	8mm 12 Point Combination Wrench	CCW27	16mm 12 Point Combination Wrench
CCW20	9mm 12 Point Combination Wrench	CCW28	17mm 12 Point Combination Wrench
CCW21	10mm 12 Point Combination Wrench	CCW29	18mm 12 Point Combination Wrench
CCW22	11mm 12 Point Combination Wrench	CCW30	19mm 12 Point Combination Wrench
CCW23	12mm 12 Point Combination Wrench	CCW31	20mm 12 Point Combination Wrench
CCW24	13mm 12 Point Combination Wrench	CCW32	21mm 12 Point Combination Wrench
CCW25	14mm 12 Point Combination Wrench		

14 Pc. 12 Point SAE Combination Wrench Set

- Incredible strength and corrosion resistance from specially formulated and heat-treated chrome alloy steel
- Off-corner loading design on box end provides better grip and reduces fastener rounding
- Sizes stamped on both sides of each wrench for easy identification
- Bright, full polish chrome finish easily wipes clean and resists corrosion
- Includes tool roll for storage and organization
- Meets or exceeds ASME and ANSI specifications



Cat. No.	Included Storage	Product Weight
CCWS4	Tool Roll	12.68 lb

Cat. No.	Description	Cat. No.	Description
CCW3	3/8" 12 Point Combination Wrench	CCW10	13/16" 12 Point Combination Wrench
CCW4	7/16" 12 Point Combination Wrench	CCW11	7/8" 12 Point Combination Wrench
CCW5	1/2" 12 Point Combination Wrench	CCW12	15/16" 12 Point Combination Wrench
CCW6	9/16" 12 Point Combination Wrench	CCW13	1" 12 Point Combination Wrench
CCW7	5/8" 12 Point Combination Wrench	CCW14	1-1/16" 12 Point Combination Wrench
CCW8	11/16" 12 Point Combination Wrench	CCW15	1-1/8" 12 Point Combination Wrench
CCW9	3/4" 12 Point Combination Wrench	CCW16	1-1/4" 12 Point Combination Wrench

10 Pc. 12 Point SAE Combination Wrench Set

- Incredible strength and corrosion resistance from specially formulated and heat-treated chrome alloy steel
- Off-corner loading design on box end provides better grip and reduces fastener rounding
- Sizes stamped on both sides of each wrench for easy identification
- Bright, full polish chrome finish easily wipes clean and resists corrosion
- Includes rack for storage and organization
- Meets or exceeds ASME and ANSI specifications



Cat. No.	Included Storage	Product Weight
CCWS2	Wrench Rack	2.34 lb

Cat. No.	Description	Cat. No.	Description
CCW0	1/4" 12 Point Combination Wrench	CCW5	1/2" 12 Point Combination Wrench
CCW1	5/16" 12 Point Combination Wrench	CCW6	9/16" 12 Point Combination Wrench
-	11/32" 12 Point Combination Wrench	CCW7	5/8" 12 Point Combination Wrench
CCW3	3/8" 12 Point Combination Wrench	CCW8	11/16" 12 Point Combination Wrench
CCW4	7/16" 12 Point Combination Wrench	CCW9	3/4" 12 Point Combination Wrench

10 Pc. 12 Point Metric Combination Wrench Set

- Incredible strength and corrosion resistance from specially formulated and heat-treated chrome alloy steel
- Off-corner loading design on box end provides better grip and reduces fastener rounding
- Sizes stamped on both sides of each wrench for easy identification
- Bright, full polish chrome finish easily wipes clean and resists corrosion
- Includes rack for storage and organization
- Meets or exceeds ASME and ANSI specifications



Cat. No.	Included Storage	Product Weight
CCWS3	Wrench Rack	2.43 lb

Cat. No.	Description	Cat. No.	Description
CCW19	8mm 12 Point Combination Wrench	CCW24	13mm 12 Point Combination Wrench
CCW20	9mm 12 Point Combination Wrench	CCW25	14mm 12 Point Combination Wrench
CCW21	10mm 12 Point Combination Wrench	CCW26	15mm 12 Point Combination Wrench
CCW22	11mm 12 Point Combination Wrench	CCW28	17mm 12 Point Combination Wrench
CCW23	12mm 12 Point Combination Wrench	CCW30	19mm 12 Point Combination Wrench

COMBINATION
WRENCHES

7 Pc. 12 Point Metric Combination Wrench Set

- Incredible strength and corrosion resistance from specially formulated and heat-treated chrome alloy steel
- Off-corner loading design on box end provides better grip and reduces fastener rounding
- Sizes stamped on both sides of each wrench for easy identification
- Bright, full polish chrome finish easily wipes clean and resists corrosion
- Includes tool roll for storage and organization
- Meets or exceeds ASME and ANSI specifications



Cat. No.	Included Storage	Product Weight
CCWSRMM7	Tool Roll	0.970 lb

Cat. No.	Description	Cat. No.	Description
-	6mm 12 Point Combination Wrench	CCW22	11mm 12 Point Combination Wrench
CCW19	8mm 12 Point Combination Wrench	CCW23	12mm 12 Point Combination Wrench
CCW20	9mm 12 Point Combination Wrench	CCW24	13mm 12 Point Combination Wrench
CCW21	10mm 12 Point Combination Wrench		

COMBINATION
WRENCHES

7 Pc. 12 Point SAE Combination Wrench Set

- Incredible strength and corrosion resistance from specially formulated and heat-treated chrome alloy steel
- Off-corner loading design on box end provides better grip and reduces fastener rounding
- Sizes stamped on both sides of each wrench for easy identification
- Bright, full polish chrome finish easily wipes clean and resists corrosion
- Includes tool roll for storage and organization
- Meets or exceeds ASME and ANSI specifications



Cat. No.	Included Storage	Product Weight
CCWSRSAE7	Tool Roll	1.000 lb

Cat. No.	Description	Cat. No.	Description
CCW0	1/4" 12 Point Combination Wrench	CCW4	7/16" 12 Point Combination Wrench
CCW1	5/16" 12 Point Combination Wrench	CCW5	1/2" 12 Point Combination Wrench
-	11/32" 12 Point Combination Wrench	CCW6	9/16" 12 Point Combination Wrench
CCW3	3/8" 12 Point Combination Wrench		

6 Pc. 12 Point SAE Combination Wrench Set

- Incredible strength and corrosion resistance from specially formulated and heat-treated chrome alloy steel
- Off-corner loading design on box end provides better grip and reduces fastener rounding
- Sizes stamped on both sides of each wrench for easy identification
- Bright, full polish chrome finish easily wipes clean and resists corrosion
- Includes rack for storage and organization
- Meets or exceeds ASME and ANSI specifications



Cat. No.	Included Storage	Product Weight
CCWS0	Wrench Rack	1.54 lb

Cat. No.	Description	Cat. No.	Description
CCW3	3/8" 12 Point Combination Wrench	CCW6	9/16" 12 Point Combination Wrench
CCW4	7/16" 12 Point Combination Wrench	CCW7	5/8" 12 Point Combination Wrench
CCW5	1/2" 12 Point Combination Wrench	CCW8	11/16" 12 Point Combination Wrench

6 Pc. 12 Point Metric Combination Wrench Set

- Incredible strength and corrosion resistance from specially formulated and heat-treated chrome alloy steel
- Off-corner loading design on box end provides better grip and reduces fastener rounding
- Sizes stamped on both sides of each wrench for easy identification
- Bright, full polish chrome finish easily wipes clean and resists corrosion
- Includes rack for storage and organization
- Meets or exceeds ASME and ANSI specifications



Cat. No.	Included Storage	Product Weight
CCWS1	Wrench Rack	1.54 lb

Cat. No.	Description	Cat. No.	Description
CCW19	8mm 12 Point Combination Wrench	CCW23	12mm 12 Point Combination Wrench
CCW20	9mm 12 Point Combination Wrench	CCW24	13mm 12 Point Combination Wrench
CCW21	10mm 12 Point Combination Wrench	CCW25	14mm 12 Point Combination Wrench

12 Point Jumbo Combination Wrenches

- Incredible strength and corrosion resistance from specially formulated and heat-treated chrome alloy steel
- Off-corner loading design on box end provides better grip and reduces fastener rounding
- Sizes stamped on both sides of each wrench for easy identification
- Bright, full polish chrome finish easily wipes clean and resists corrosion
- Meets or exceeds ASME and ANSI specifications



Cat. No.	SAE/Metric	Fastener Size	End A Width	End A Thickness	End B Width	End B Thickness	Overall Length	Product Weight
CJCW0	SAE	1-5/16 in	71 in	14.5 in	49.6 in	21.4 in	18.70 in	2.23 lb
CJCW1	SAE	1-3/8 in	71 in	14.5 in	49.6 in	21.4 in	18.70 in	2.40 lb
CJCW2	SAE	1-7/16 in	78.8 in	15.5 in	55.5 in	23.5 in	19.69 in	3.18 lb
CJCW3	SAE	1-1/2 in	78.8 in	15.5 in	55.5 in	23.5 in	19.69 in	3.34 lb
CJCW4	SAE	1-5/8 in	86.8 in	16.5 in	61 in	24.6 in	22.83 in	4.21 lb
CJCW5	SAE	1-11/16 in	88.6 in	20.1 in	65 in	25.4 in	22.83 in	4.45 lb
CJCW6	SAE	1-3/4 in	88.6 in	20.1 in	65 in	25.4 in	24.02 in	5.27 lb
CJCW7	SAE	1-13/16 in	94 in	21.2 in	69 in	25.4 in	24.02 in	5.51 lb
CJCW8	SAE	1-7/8 in	94 in	21.2 in	69 in	25.4 in	25.59 in	6.68 lb
CJCW9	SAE	2 in	3.94 in	0.85 in	2.93 in	1.04 in	25.59 in	6.61 lb

12 Point Combination Wrenches

- Incredible strength and corrosion resistance from specially formulated and heat-treated chrome alloy steel
- Off-corner loading design on box end provides better grip and reduces fastener rounding
- Sizes stamped on both sides of each wrench for easy identification
- Bright, full polish chrome finish easily wipes clean and resists corrosion
- Meets or exceeds ASME and ANSI specifications



Cat. No.	SAE/Metric	Fastener Size	End A Width	End A Thickness	End B Width	End B Thickness	Overall Length	Product Weight
CCW0	SAE	1/4 in	0.51 in	0.13 in	0.44 in	0.17 in	5.00 in	0.06 lb
CCW1	SAE	5/16 in	0.64 in	0.15 in	.053 in	0.19 in	5.51 in	0.07 lb
CCW3	SAE	3/8 in	0.80 in	0.17 in	0.62 in	0.23 in	6.22 in	0.12 lb
CCW4	SAE	7/16 in	22.41 in	4.8 in	17.19 in	6.5 in	6.50 in	0.15 lb
CCW5	SAE	1/2 in	26.45 in	5.4 in	19.55 in	7.7 in	6.97 in	0.17 lb
CCW6	SAE	9/16 in	1.13 in	0.23 in	0.84 in	0.33 in	7.52 in	0.20 lb
CCW7	SAE	5/8 in	1.28 in	0.25 in	0.93 in	0.37 in	8.19 in	0.29 lb
CCW8	SAE	11/16 in	34.77 in	6.8 in	25.51 in	9.9 in	8.90 in	0.31 lb
CCW9	SAE	3/4 in	1.54 in	0.31 in	1.09 in	0.43 in	9.76 in	0.44 lb
CCW10	SAE	13/16 in	42.75 in	8.3 in	30.11 in	11.8 in	10.67 in	0.62 lb
CCW11	SAE	7/8 in	1.77 in	0.34 in	1.25 in	0.48 in	11.54 in	0.64 lb
CCW12	SAE	15/16 in	48.96 in	9.3 in	33.29 in	13.3 in	12.40 in	0.86 lb
CCW13	SAE	1 in	2.01 in	0.38 in	1.46 in	0.54 in	13.15 in	0.88 lb
CCW14	SAE	1-1/16 in	2.21 in	0.40 in	1.52 in	0.59 in	14.13 in	1.21 lb
CCW15	SAE	1-1/8 in	61.1 in	11.1 in	42.41 in	16.3 in	15.87 in	1.43 lb
CCW16	SAE	1-1/4 in	66.45 in	11.5 in	45.56 in	16.8 in	16.95 in	1.94 lb
CCW18	Metric	7 mm	0.56 in	0.13 in	0.47 in	0.17 in	5.28 in	0.06 lb
CCW19	Metric	8 mm	0.64 in	0.15 in	0.53 in	0.19 in	5.51 in	0.07 lb
CCW20	Metric	9 mm	0.72 in	0.16 in	0.57 in	0.21 in	5.91 in	0.09 lb
CCW21	Metric	10 mm	0.80 in	0.17 in	0.62 in	0.23 in	6.22 in	0.12 lb
CCW22	Metric	11 mm	0.88 in	0.19 in	0.68 in	0.26 in	6.50 in	0.15 lb
CCW23	Metric	12 mm	0.96 in	0.20 in	0.72 in	0.28 in	6.77 in	0.16 lb
CCW24	Metric	13 mm	1.04 in	0.21 in	0.77 in	0.30 in	6.97 in	0.17 lb
CCW25	Metric	14 mm	1.13 in	0.23 in	0.84 in	0.33 in	7.52 in	0.20 lb
CCW26	Metric	15 mm	1.20 in	0.24 in	0.88 in	0.35 in	7.87 in	0.28 lb
CCW27	Metric	16 mm	1.28 in	0.25 in	0.93 in	0.37 in	8.19 in	0.29 lb
CCW28	Metric	17 mm	1.37 in	0.27 in	1 in	0.39 in	8.90 in	0.31 lb
CCW29	Metric	18 mm	1.45 in	0.29 in	1.04 in	0.41 in	9.33 in	0.42 lb
CCW30	Metric	19 mm	1.54 in	0.31 in	1.09 in	0.43 in	9.76 in	0.44 lb
CCW31	Metric	20 mm	1.68 in	0.33 in	1.19 in	0.46 in	10.43 in	0.61 lb
CCW32	Metric	21 mm	1.68 in	0.33 in	1.19 in	0.46 in	10.67 in	0.62 lb
CCW33	Metric	22 mm	1.77 in	0.34 in	1.25 in	0.48 in	11.54 in	0.64 lb
CCW35	Metric	24 mm	48.96 in	9.3 in	33.29 in	13.3 in	12.40 in	0.86 lb

7 Pc. X6™ SAE Ratcheting Open End Wrench Set

- Ratcheting open end turn nuts and bolts without removing the wrench from the fastener
- Universal spline box end fits six common styles of fasteners hex, square, 12 pt., E-Torx®, rounded hex, and spline
- Rapid ratcheting action turns fasteners in tight spaces
- Ergonomic beams let you apply more torque to fasteners
- Laser-etched size markings make identifying the correct tool quick and easy
- Specially formulated and heat-treated chrome alloy steel construction for superior strength and resistance to corrosion
- Meets or exceeds ASME and ANSI specifications
- For fasteners that do not engage the box end of the wrench, the open end may be used



Cat. No.	Included Storage	Product Weight
CX6RWS7	Tray	2.64 lb



Cat. No.	Description	Cat. No.	Description
-	5/16" X6™ Spline Open End Ratcheting Combination Wrench	-	9/16" X6™ Spline Open End Ratcheting Combination Wrench
-	3/8" X6™ Spline Open End Ratcheting Combination Wrench	-	5/8" X6™ Spline Open End Ratcheting Combination Wrench
-	7/16" X6™ Spline Open End Ratcheting Combination Wrench	-	11/16" X6™ Spline Open End Ratcheting Combination Wrench
-	1/2" X6™ Spline Open End Ratcheting Combination Wrench		

7 Pc. X6™ Metric Ratcheting Open End Wrench Set

- Ratcheting open end turn nuts and bolts without removing the wrench from the fastener
- Universal spline box end fits six common styles of fasteners hex, square, 12 pt., E-Torx®, rounded hex, and spline
- Rapid ratcheting action turns fasteners in tight spaces
- Ergonomic beams let you apply more torque to fasteners
- Laser-etched size markings make identifying the correct tool quick and easy
- Specially formulated and heat-treated chrome alloy steel construction for superior strength and resistance to corrosion
- Meets or exceeds ASME and ANSI specifications
- For fasteners that do not engage the box end of the wrench, the open end may be used



Cat. No.	Included Storage	Product Weight
CX6RWM7	Tray	2.64 lb



Cat. No.	Description	Cat. No.	Description
-	8mm X6™ Spline Open End Ratcheting Combination Wrench	-	14mm X6™ Spline Open End Ratcheting Combination Wrench
-	10mm X6™ Spline Open End Ratcheting Combination Wrench	-	15mm X6™ Spline Open End Ratcheting Combination Wrench
-	12mm X6™ Spline Open End Ratcheting Combination Wrench	-	17mm X6™ Spline Open End Ratcheting Combination Wrench
-	13mm X6™ Spline Open End Ratcheting Combination Wrench		

2 Pc. X6™ 4-in-1 SAE Ratcheting Wrench Set

- 5° ratcheting arc lets you turn fasteners in tight spaces
- Universal spline box end fits six common styles of fasteners hex, square, 12 pt., E-Torx®, rounded hex, and spline
- The most versatile wrenches available each X6 can be used on six different styles of fasteners, in four common sizes
- Ergonomic beams let you apply more torque to fasteners
- Specially formulated and heat-treated chrome alloy steel construction for superior strength and resistance to corrosion
- Includes tray for storage and organization
- Some square nuts and bolts may not engage with ratcheting box ends



Cat. No.	Included Storage	Product Weight
CX6DBS2	None	1.10 lb



Cat. No.	Description
-	X6™ 4-in-1 Spline Reversible Ratcheting Wrench 5/16" x 3/8" & 7/16 x 1/2"
-	X6™ 4-in-1 Spline Reversible Ratcheting Wrench 9/16" x 5/8" & 11/16 x 3/4"

2 Pc. X6™ 4-in-1 Metric Ratcheting Wrench Set

- 5° ratcheting arc lets you turn fasteners in tight spaces
- Universal spline box end fits six common styles of fasteners hex, square, 12 pt., E-Torx®, rounded hex, and spline
- The most versatile wrenches available each X6 can be used on six different styles of fasteners, in four common sizes
- Ergonomic beams let you apply more torque to fasteners
- Specially formulated and heat-treated chrome alloy steel construction for superior strength and resistance to corrosion
- Includes tray for storage and organization
- Some square nuts and bolts may not engage with ratcheting box ends



Cat. No.	Included Storage	Product Weight
CX6DBM2	None	1.10 lb



Cat. No.	Description
-	X6™ 4-in-1 Spline Reversible Ratcheting Wrench 8mm x 10mm & 12mm x 13mm
-	X6™ 4-in-1 Spline Reversible Ratcheting Wrench 14mm x 15mm & 17mm x 19mm

3 Pc. 3/8" Drive SAE Flare Nut Wrench Set

- Hex shaped heads give more points of contact on the fastener to prevent damage
- Ideal for use on hex nuts made of softer materials
- Manufactured from chrome vanadium steel for better strength and longer tool life
- Bright, full polish chrome finish easily wipes clean and resists corrosion
- Sizes stamped on both sides of the wrench beam for quick identification
- Meets or exceeds ASME and ANSI specifications



SAE

Cat. No.	Included Storage	Product Weight
CFNWSO	None	0.72 lb

Cat. No.	Description
-	Flare Nut Wrench 3/8" x 7/16"
-	Flare Nut Wrench 1/2" x 9/16"
-	Flare Nut Wrench 5/8" x 11/16"

3 Pc. 3/8" Drive Metric Flare Nut Wrench Set

- Hex shaped heads give more points of contact on the fastener to prevent damage
- Ideal for use on hex nuts made of softer materials
- Manufactured from chrome vanadium steel for better strength and longer tool life
- Bright, full polish chrome finish easily wipes clean and resists corrosion
- Sizes stamped on both sides of the wrench beam for quick identification
- Meets or exceeds ASME and ANSI specifications



mm

Cat. No.	Included Storage	Product Weight
CFNWS1	None	0.72 lb

Cat. No.	Description
-	Flare Nut Wrench 9mm x 11mm
-	Flare Nut Wrench 10mm x 12mm
-	Flare Nut Wrench 13mm x 14mm

10 Pc. 3/8" Drive SAE Flare Nut Set

- Hex shaped heads give more points of contact on the fastener to prevent damage
- Ideal for use on hex nuts made of softer materials
- Manufactured from chrome alloy steel for better strength and longer tool life
- Bright, full polish chrome finish easily wipes clean and resists corrosion
- Includes socket rail for storage and organization
- Meets or exceeds ASME and ANSI specifications



SAE

Cat. No.	Included Storage	Product Weight
CCFWSO	Socket Rail	1.650 lb

Cat. No.	Description	Cat. No.	Description
-	3/8" Drive Flare Nut Wrench 3/8"	-	3/8" Drive Flare Nut Wrench 11/16"
-	3/8" Drive Flare Nut Wrench 7/16"	-	3/8" Drive Flare Nut Wrench 3/4"
-	3/8" Drive Flare Nut Wrench 1/2"	-	3/8" Drive Flare Nut Wrench 13/16"
-	3/8" Drive Flare Nut Wrench 9/16"	-	3/8" Drive Flare Nut Wrench 7/8"
-	3/8" Drive Flare Nut Wrench 5/8"	-	3/8" Drive Flare Nut Wrench 1"

10 Pc. 3/8" Drive Metric Flare Nut Set

- Hex shaped heads give more points of contact on the fastener to prevent damage
- Ideal for use on hex nuts made of softer materials
- Manufactured from chrome alloy steel for better strength and longer tool life
- Bright, full polish chrome finish easily wipes clean and resists corrosion
- Includes socket rail for storage and organization
- Meets or exceeds ASME and ANSI specifications



mm

Cat. No.	Included Storage	Product Weight
CCFWS1N	Socket Rail	1.340 lb

Cat. No.	Description	Cat. No.	Description
-	3/8" Drive Flare Nut Wrench 9mm	-	3/8" Drive Flare Nut Wrench 14mm
-	3/8" Drive Flare Nut Wrench 10mm	-	3/8" Drive Flare Nut Wrench 15mm
-	3/8" Drive Flare Nut Wrench 11mm	-	3/8" Drive Flare Nut Wrench 17mm
-	3/8" Drive Flare Nut Wrench 12mm	-	3/8" Drive Flare Nut Wrench 18mm
-	3/8" Drive Flare Nut Wrench 13mm	-	3/8" Drive Flare Nut Wrench 19mm

3/8" Micrometer Torque Wrench

- Reversible 45-tooth round ratcheting head
- Accuracy within 4% of specified torque target
- Clockwise direction marking on shaft simplifies calibration
- Slide-back adjustment collar lets you set the target torque quickly and easily
- SAE and metric scales on the hand grip and shaft are large and easy to read
- Audible signal alerts you when you reach the target torque
- Bright, full polish chrome finish easily wipes clean and resists corrosion
- Non-slip hand grip is comfortable and adjusts quickly
- Meets or exceeds ASME specifications
- 1 year limited warranty; calibration accuracy warranted for 90 days



Cat. No.	Drive Tang Size	Primary Scale Range - Max Torque	Primary Scale Increments	Alternate Scale Range - Max Torque	Alt Scale Increments	Head Thickness	Head Width	Overall Length	Product Weight
CRTW38	3/8 in	50 in/lb - 250 in/lb	1 in/lb	6 Nm - 30 Nm	.1 Nm	1.3 in	1.3 in	14.375 in	2.485 lb

1/2" Micrometer Torque Wrench

- Reversible 45-tooth round ratcheting head
- Accuracy within 4% of specified torque target
- Clockwise direction marking on shaft simplifies calibration
- Slide-back adjustment collar lets you set the target torque quickly and easily
- SAE and metric scales on the hand grip and shaft are large and easy to read
- Audible signal alerts you when you reach the target torque
- Bright, full polish chrome finish easily wipes clean and resists corrosion
- Non-slip hand grip is comfortable and adjusts quickly
- Meets or exceeds ASME specifications
- 1 year limited warranty; calibration accuracy warranted for 90 days



Cat. No.	Drive Tang Size	Primary Scale Range - Max Torque	Primary Scale Increments	Alternate Scale Range - Max Torque	Alt Scale Increments	Head Thickness	Head Width	Overall Length	Product Weight
CRTW12	1/2 in	50 ft/lb - 250 ft/lb	1 ft/lb	70 Nm - 340 Nm	1.5 Nm	1.8 in	1.625 in	23.25 in	4.200 lb



Power Tool Accessories

eSHOK-GUARD™ • u-GUARD™ • Screwdriver Bits
Nutsetters • Bit Holders

The Crescent APEX eSHOK-GUARD™ Isolated Power Tool Accessories

85% of professionals experiencing shocks on construction job sites. Protect yourself from electric shock with Crescent APEX's new patented isolated technology, eSHOK-GUARD™, providing insulation of up to 1,000 volts. Combining safety and convenience for a revolutionary experience when working around potential live wire applications, eSHOK-GUARD™ is protecting you – for life.

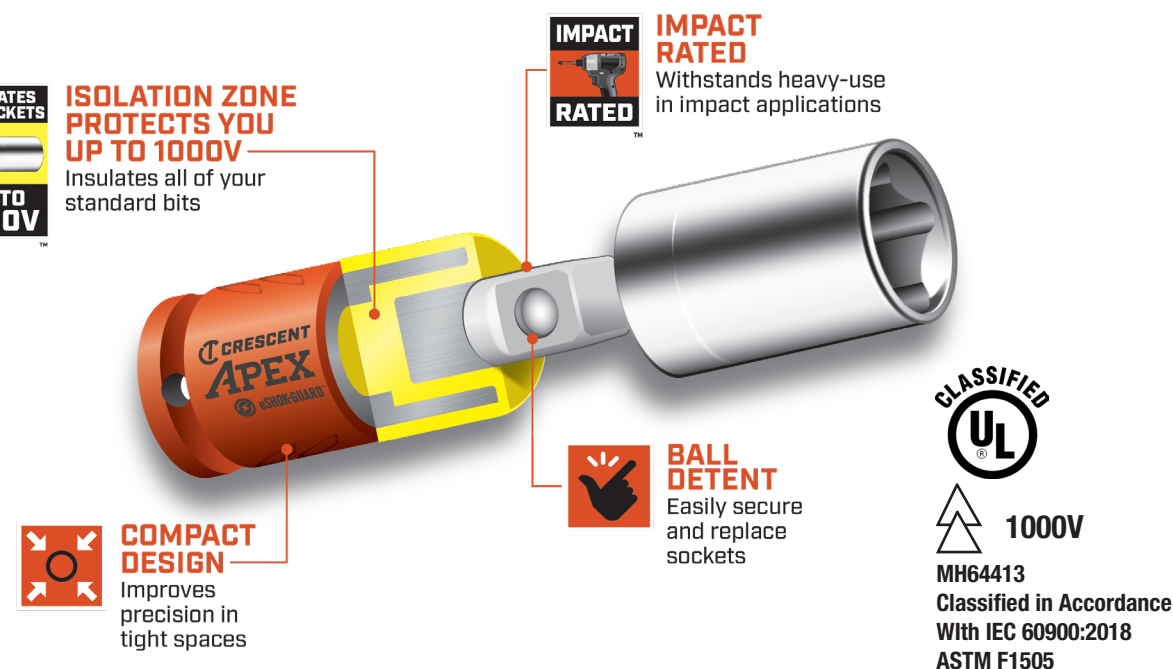
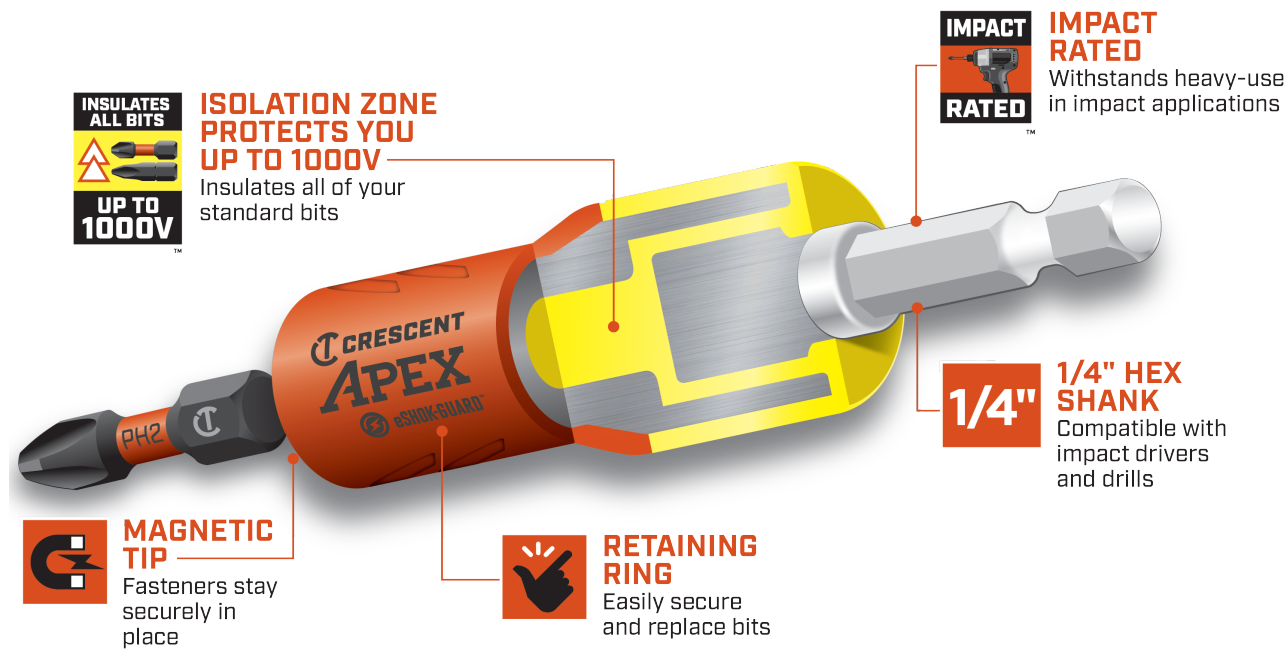

eSHOK-GUARD™ Isolated Bit Holder

- Isolation zone insulates all your standard bits, protecting you up to 1000V
- Withstands heavy-use in impact applications
- Magnetic tip keeps fasteners securely in place
- Easily secure and replace bits with a retaining ring
- 1/4" hex shank is compatible with impact drivers and drills



Cat. No.	Size	Overall Length	Rated Voltage	Product Weight
CAEBH2C	1/4 in	3 in	1000V	0.492 lb

eSHOK-GUARD™ Socket Isolators

- Isolation zone insulates all your standard bits, protecting you up to 1000V
- Withstands heavy-use in impact applications
- Compact design improves precision in tight spaces
- Ball detent for secure fastener retention and easy replacement



Cat. No.	Size	Overall Length	Rated Voltage	Product Weight
CAEAD316	1/4 in	2.125 in	1000V	0.137 lb
CAEAD324	3/8 in	2.25 in	1000V	0.168 lb
CAEAD332	1/2 in	2.625 in	1000V	0.284 lb

u-GUARD™ Covered Bit Holders

- Non-marring cover protects from scratching or damages
- Thin wall maximizes access
- Free spinning sleeve enhances control and safety
- Full body design for greater strength and durability
- Optimized tip geometry for exact fastener fitment
- Helps to eliminate cam-out and promotes fastener retention



Cat. No.	Size	Overall Length	Product Weight
AUGBQ2A-1	1/4 in	2.25 in	0.101 lb
AUGBH3-1	1/4 in	3 in	0.124 lb

The Crescent APEX u-GUARD™ Non-Marring Covered Tools

The Crescent APEX series of u-GUARD™ non-marring covered tools gives you protection and control on the jobsite. These patented tools allow the user to grab directly onto the drive tool while it spins freely inside the cover, increasing fastening control and significantly reducing contact from the rotating tool.



NON-MARRING
Non-Marring Cover protects from scratching or damages; Thin Wall Maximizes access



SAFETY
Free Spinning Sleeve for enhanced control and safety

2X

DURABILITY
Full Body Design for greater strength & durability

Optimized Tip Geometry for best fit



30 Pc. u-GUARD™ alphaCASE™ Set

- Non-marring cover protects from scratching or damages
- Free spinning design enhances control and safety
- Optimized tip geometry for best fit (50% better grip measured on Phillips® bit only)
- Superior durability to withstand the toughest jobs
- Full body design for greater strength and durability
- Proprietary heat treat process maximizes bit life (2x more durable)
- Pivoting insert rails for ease of use
- Stackable for convenient storage



Cat. No.	Included Storage	Product Weight
AUGSET-30	alphaCASE™	1.583 lb

Cat. No.	Description	Qty.	Cat. No.	Description	Qty.
AMB1SL6	6 - 8 x 1" Slotted Insert Bit	1	AMB2TX25	T25 x 2" Torx® Power Insert Bit	2
AMB1TX20	T20 x 1" Torx® Insert Bit	1	AUMB3BPH2	#2 Phillips® u-GUARD™ Covered Impact Power Bit with Ring Magnet	1
AMB1TX25	T25 x 1" Torx® Insert Bit	4	AUGB3BTX25	T25 Torx® u-GUARD™ Covered Impact Power Bit	1
AMB1SQ2	#2 x 1" Square Insert Bit	2	AUGN2B20	5/16" u-GUARD™ Covered Magnetic Nutsetter	1
AMB1PH1	#1 x 1" Phillips® Insert Bit	2	AUGN2B16	1/4" u-GUARD™ Covered Magnetic Nutsetter	1
AMB1PH2	#2 x 1" Phillips® Insert Bit	6	AUGBQ2A	u-GUARD™ Covered Quick Release Bit Holder 1/4" x 2-1/4"	1
AMB2PH2	#2 x 2" Phillips® Power Insert Bit	4	AMBQ2A	2-1/4" Quick Release Bit Holder	1
AMB2SQ2	#2 x 2" Square Power Insert Bit	2			

3 Pc. u-GUARD™ Covered Magnetic Nutsetter Set

- Non-marring cover protects from scratching or damages
- Thin wall maximizes access
- Free spinning sleeve enhances control and safety
- Full body design for greater strength and durability
- Optimized tip geometry for exact fastener fitment
- Helps to eliminate cam-out and promotes fastener retention



Cat. No.	Included Storage	Product Weight
AUGN2BSET-3	None	0.240 lb

Cat. No.	Description
AUGN2B16	1/4" u-GUARD™ Covered Magnetic Nutsetter
AUGN2B20	5/16" u-GUARD™ Covered Magnetic Nutsetter
AUGN2B24	3/8" u-GUARD™ Covered Magnetic Nutsetter

u-GUARD™ Covered Magnetic Nutsetters

- Non-marring cover protects from scratching or damages
- Thin wall maximizes access
- Free spinning sleeve enhances control and safety
- Full body design for greater strength and durability
- Optimized tip geometry for exact fastener fitment
- Helps to eliminate cam-out and promotes fastener retention



Cat. No.	Size	Overall Length	Product Weight
AUGN2B16-1	1/4 in	2.56 in	0.095 lb
AUGN2B20-1	5/16 in	2.56 in	0.100 lb
AUGN2B24-1	3/8 in	2.56 in	0.101 lb
AUGN2B28-1	7/16 in	2.56 in	0.131 lb
AUGN2B32-1	1/2 in	2.56 in	0.155 lb

u-GUARD™ Covered Impact Power Bits

- Non-marring cover protects from scratching or damages
- Thin wall maximizes access
- Free spinning sleeve enhances control and safety
- Full body design for greater strength and durability
- Optimized tip geometry for exact fastener fitment
- Helps to eliminate cam-out and promotes fastener retention



Cat. No.	Tip Style	Tip Size	Overall Length	Product Weight
AUGB3BPH2-1	Phillips®	#2	3.5 in	0.081 lb
AUGB3BSQ2-1	Square	#2	3.5 in	0.080 lb
AUGB3BTX25-1	Torx®	T25	3.5 in	0.067 lb

u-GUARD™ Covered Magnetic Impact Power Bits

- Non-marring cover protects from scratching or damages
- Thin wall maximizes access
- Free spinning sleeve enhances control and safety
- Full body design for greater strength and durability
- Optimized tip geometry for exact fastener fitment
- Helps to eliminate cam-out and promotes fastener retention



Cat. No.	Tip Style	Tip Size	Overall Length	Product Weight
AUMB3BPH2-1	Phillips®	#2	3.5 in	0.080 lb
AUMB3BSQ2-1	Square	#2	3.5 in	0.079 lb
AUMB3BTX25-1	Torx®	T25	3.5 in	0.075 lb

38 Pc. alphaCASE™ Set

- Superior durability to withstand the toughest jobs
- Optimized tip geometry for exact fastener fitment
- Helps to eliminate cam-out and promotes fastener retention
- Modified S2 steel and proprietary heat treat process maximizes bit life
- Attachment points for versatility on the job
- Full length metal hinge for improved case life
- Pivoting insert rails for ease of use
- Stackable for convenient storage
- Exterior labels for visibility and marking



Cat. No.	Included Storage	Product Weight
AMSET-38	alphaCASE™	1.282 lb

Cat. No.	Description	Qty.	Cat. No.	Description	Qty.
AMB2PH2	#2 x 2" Phillips® Power Insert Bit	2	AMB1PH2	#2 x 1" Phillips® Insert Bit	8
AMB2SQ2	#2 x 2" Square Power Insert Bit	1	AMB1PH3	#3 x 1" Phillips® Insert Bit	2
AMB2TX25	T25 x 2" Torx® Power Insert Bit	2	AMB1SL6	6 - 8 x 1" Slotted Insert Bit	2
AMN2B16	1/4" x 2-9/16" Magnetic Nutsetter	1	AMB1TX20	T20 x 1" Torx® Insert Bit	2
AMN2B20	5/16" x 2-9/16" Magnetic Nutsetter	1	AMB1TX25	T25 x 1" Torx® Insert Bit	6
AMBQ2A	2-1/4" Quick Release Bit Holder	1	AMB1SQ1	#1 x 1" Square Insert Bit	2
AMB1PH1	#1 x 1" Phillips® Insert Bit	2	AMB1SQ2	#2 x 1" Square Insert Bit	6

9 Pc. SAE Hex Insert Bit Set

- Full body design for greater strength and durability
- Optimized tip geometry for exact fastener fitment; helps to eliminate cam-out and promotes fastener retention
- Modified S2 steel and proprietary heat treat process maximizes bit life
- Laser markings for long-lasting quick and easy size identification



Cat. No.	Included Storage	Product Weight
AMB1HXSET-9	None	0.090 lb

Cat. No.	Description	Cat. No.	Description
AMB1HX5	5/64" x 1" SAE Hex Insert Bit	AMB1HX10	5/32" x 1" SAE Hex Insert Bit
AMB1HX6	3/32" x 1" SAE Hex Insert Bit	AMB1HX12	3/16" x 1" SAE Hex Insert Bit
AMB1HX7	7/64" x 1" SAE Hex Insert Bit	AMB1HX14	7/32" x 1" SAE Hex Insert Bit
AMB1HX8	1/8" x 1" SAE Hex Insert Bit	AMB1HX16	1/4" x 1" SAE Hex Insert Bit
AMB1HX9	9/64" x 1" SAE Hex Insert Bit		

u-GUARD™

INSERT BITS

6 Pc. Metric Hex Insert Bit Set

- Full body design for greater strength and durability
- Optimized tip geometry for exact fastener fitment; helps to eliminate cam-out and promotes fastener retention
- Modified S2 steel and proprietary heat treat process maximizes bit life
- Laser markings for long-lasting quick and easy size identification



Cat. No.	Included Storage	Product Weight
AMB1HMSET-6	None	0.065 lb

Cat. No.	Description	Cat. No.	Description
AMB1HM2	2mm x 1" Metric Hex Insert Bit	AMB1HM4	4mm x 1" Metric Hex Insert Bit
AMB1HM25	2.5mm x 1" Metric Hex Insert Bit	AMB1HM5	5mm x 1" Metric Hex Insert Bit
AMB1HM3	3mm x 1" Metric Hex Insert Bit	AMB1HM6	6mm x 1" Metric Hex Insert Bit

7 Pc. Security Hex Insert Bit Set

- Full body design for greater strength and durability
- Optimized tip geometry for exact fastener fitment; helps to eliminate cam-out and promotes fastener retention
- Modified S2 steel and proprietary heat treat process maximizes bit life
- Laser markings for long-lasting quick and easy size identification



Cat. No.	Included Storage	Product Weight
AMB1HXRSET-7	None	0.090 lb

Cat. No.	Description	Cat. No.	Description
AMB1HXR10	5/32" x 1" SAE Security Hex Insert Bit	AMB1HXR7	7/64" x 1" SAE Security Hex Insert Bit
AMB1HXR12	3/16" x 1" SAE Security Hex Insert Bit	AMB1HXR8	1/8" x 1" SAE Security Hex Insert Bit
AMB1HXR5	5/64" x 1" SAE Security Hex Insert Bit	AMB1HXR9	9/64" x 1" SAE Security Hex Insert Bit
AMB1HXR6	3/32" x 1" SAE Security Hex Insert Bit		

7 Pc. Tamper Proof Torx® Insert Bit Set

- Full body design for greater strength and durability
- Optimized tip geometry for exact fastener fitment; helps to eliminate cam-out and promotes fastener retention
- Modified S2 steel and proprietary heat treat process maximizes bit life
- Laser markings for long-lasting quick and easy size identification



Cat. No.	Included Storage	Product Weight
AMB1TRSET-7	None	0.095 lb

Cat. No.	Description	Cat. No.	Description
AMB1TR10	T10 x 1" Tamper Proof Torx® Insert Bit	AMB1TR27	T27 x 1" Tamper Proof Torx® Insert Bit
AMB1TR15	T15 x 1" Tamper Proof Torx® Insert Bit	AMB1TR30	T30 x 1" Tamper Proof Torx® Insert Bit
AMB1TR20	T20 x 1" Tamper Proof Torx® Insert Bit	AMB1TR40	T40 x 1" Tamper Proof Torx® Insert Bit
AMB1TR25	T25 x 1" Tamper Proof Torx® Insert Bit		

Insert Bits

- Full body design for greater strength and durability
- Optimized tip geometry for exact fastener fitment
- Helps to eliminate cam-out and promotes fastener retention
- Modified S2 steel and proprietary heat treat process maximizes bit life
- Laser markings for long-lasting quick and easy size identification



Cat. No.	Tip Style	Tip Size	Overall Length	Quantity Per Package	Product Weight
AMB1HX5-25	Hex	5/64 in	1 in	25	0.010 lb
AMB1HX6-25	Hex	3/32 in	1 in	25	0.012 lb
AMB1HX7-25	Hex	7/64 in	1 in	25	0.012 lb
AMB1HX8-25	Hex	1/8 in	1 in	25	0.012 lb
AMB1HX9-25	Hex	9/64 in	1 in	25	0.012 lb
AMB1HX10-25	Hex	5/32 in	1 in	25	0.011 lb
AMB1HX12-25	Hex	3/16 in	1 in	25	0.012 lb
AMB1HX14-25	Hex	7/32 in	1 in	25	0.015 lb
AMB1HX16-25	Hex	1/4 in	1 in	25	0.017 lb
AMB1HM2-25	Hex	2mm	1 in	25	0.012 lb
AMB1HM25-25	Hex	2.5mm	1 in	25	0.011 lb
AMB1HM3-25	Hex	3mm	1 in	25	0.013 lb
AMB1HM4-25	Hex	4mm	1 in	25	0.013 lb
AMB1HM5-25	Hex	5mm	1 in	25	0.013 lb
AMB1HM6-25	Hex	6mm	1 in	25	0.015 lb
AMB1HXR5-25	Security Hex	5/64 in	1 in	25	0.011 lb
AMB1HXR6-25	Security Hex	3/32 in	1 in	25	0.012 lb
AMB1HXR7-25	Security Hex	7/64 in	1 in	25	0.011 lb
AMB1HXR8-25	Security Hex	1/8 in	1 in	25	0.011 lb
AMB1HXR9-25	Security Hex	9/64 in	1 in	25	0.010 lb
AMB1HXR10-25	Security Hex	5/32 in	1 in	25	0.011 lb
AMB1HXR12-25	Security Hex	3/16 in	1 in	25	0.013 lb
AMB1PH1-2	Phillips®	#1	1 in	2	0.030 lb
AMB1PH1-50	Phillips®	#1	1 in	50	0.012 lb
AMB1PH2-2	Phillips®	#2	1 in	2	0.080 lb
AMB1PH2-10	Phillips®	#2	1 in	10	0.105 lb
AMB1PH2-15	Phillips®	#2	1 in	15	0.265 lb

■ Continued on next page

INSERT BITS

INSERT BITS

Insert Bits ■ Continued from previous page

Cat. No.	Tip Style	Tip Size	Overall Length	Quantity Per Package	Product Weight
AMB1PH2-30	Phillips®	#2	1 in	30	0.440 lb
AMB1PH2-50	Phillips®	#2	1 in	50	0.010 lb
AMB1PH3-2	Phillips®	#3	1 in	2	0.080 lb
AMB1PH3-50	Phillips®	#3	1 in	50	0.010 lb
AMB1PH4-25	Phillips®	#4	1 in	25	0.011 lb
AMB1PT1-50	Recessed Phillips®	#1	1 in	50	0.010 lb
AMB1PT2-2	Recessed Phillips®	#2	1 in	2	0.025 lb
AMB1PT2-50	Recessed Phillips®	#2	1 in	50	0.008 lb
AMB1SL1-25	Slotted	1 - 2	1 in	25	0.009 lb
AMB1SL2-25	Slotted	2 - 3	1 in	25	0.009 lb
AMB1SL3-25	Slotted	3 - 4	1 in	25	0.001 lb
AMB1SL4-25	Slotted	4 - 5	1 in	25	0.011 lb
AMB1SL6-25	Slotted	6 - 8	1 in	25	0.011 lb
AMB1SL8-2	Slotted	8 - 10	1 in	2	0.030 lb
AMB1SL8-25	Slotted	8 - 10	1 in	25	0.011 lb
AMB1SQ1-2	Square	#1	1 in	2	0.080 lb
AMB1SQ1-50	Square	#1	1 in	50	0.012 lb
AMB1SQ2-2	Square	#2	1 in	2	0.035 lb
AMB1SQ2-10	Square	#2	1 in	10	0.152 lb
AMB1SQ2-50	Square	#2	1 in	50	0.013 lb
AMB1SQ3-50	Square	#3	1 in	50	0.013 lb
AMB1TX10-25	Torx®	T10	1 in	25	0.012 lb
AMB1TX15-2	Torx®	T15	1 in	2	0.030 lb
AMB1TX15-25	Torx®	T15	1 in	25	0.012 lb
AMB1TX20-2	Torx®	T20	1 in	2	0.025 lb
AMB1TX20-25	Torx®	T20	1 in	25	0.012 lb
AMB1TX25-2	Torx®	T25	1 in	2	0.060 lb
AMB1TX25-10	Torx®	T25	1 in	10	0.155 lb
AMB1TX25-15	Torx®	T25	1 in	15	0.255 lb
AMB1TX25-30	Torx®	T25	1 in	30	0.390 lb
AMB1TX25-50	Torx®	T25	1 in	50	0.012 lb
AMB1TX27-50	Torx®	T27	1 in	50	0.012 lb
AMB1TX30-50	Torx®	T30	1 in	50	0.013 lb
AMB1TX40-25	Torx®	T40	1 in	25	0.015 lb
AMB1TR10-25	Tamper-Proof Torx®	T10	1 in	25	0.012 lb
AMB1TR15-25	Tamper-Proof Torx®	T15	1 in	25	0.001 lb
AMB1TR20-25	Tamper-Proof Torx®	T20	1 in	25	0.012 lb
AMB1TR25-25	Tamper-Proof Torx®	T25	1 in	25	0.013 lb
AMB1TR27-25	Tamper-Proof Torx®	T27	1 in	25	0.013 lb
AMB1TR30-25	Tamper-Proof Torx®	T30	1 in	25	0.014 lb
AMB1TR40-25	Tamper-Proof Torx®	T40	1 in	25	0.015 lb
AMB1PZ1-25	Pozidriv®	#1	1 in	25	0.007 lb
AMB1PZ2-25	Pozidriv®	#2	1 in	25	0.013 lb
AMB1PZ3-25	Pozidriv®	#3	1 in	25	0.008 lb

Power Insert Bits

- Full body design for greater strength and durability
- Optimized tip geometry for exact fastener fitment
- Helps to eliminate cam-out and promotes fastener retention
- Modified S2 steel and proprietary heat treat process maximizes bit life
- Laser markings for long-lasting quick and easy size identification



Cat. No.	Tip Style	Tip Size	Overall Length	Quantity Per Package	Product Weight
AMB2PH1-50	Phillips®	#1	2 in	50	0.023 lb
AMB2CPH1-25	Phillips®	#1	2.75 in	25	0.026 lb
AMB3BPH1-25	Phillips®	#1	3.5 in	25	0.031 lb
AMB6PH1-25	Phillips®	#1	6 in	25	0.052 lb
AMB2PH2-1	Phillips®	#2	2 in	1	0.060 lb
AMB2PH2-5	Phillips®	#2	2 in	5	0.165 lb
AMB2PH2-15	Phillips®	#2	2 in	15	0.410 lb
AMB2PH2-50	Phillips®	#2	2 in	50	0.024 lb
AMB2CPH2-25	Phillips®	#2	2.75 in	25	0.036 lb
AMB3BPH2-1	Phillips®	#2	3.5 in	1	0.060 lb
AMB3BPH2-25	Phillips®	#2	3.5 in	25	0.045 lb
AMB6PH2-1	Phillips®	#2	6 in	1	0.095 lb
AMB6PH2-25	Phillips®	#2	6 in	25	0.080 lb
AMB2PH3-50	Phillips®	#3	2 in	50	0.023 lb
AMB2CPH3-25	Phillips®	#3	2.75 in	25	0.049 lb
AMB3BPH3-25	Phillips®	#3	3.5 in	25	0.065 lb
AMB6PH3-25	Phillips®	#3	6 in	25	0.122 lb
AMB2SL4-25	Slotted	4 - 5	2 in	25	0.021 lb
AMB2SL6-25	Slotted	6 - 8	2 in	25	0.027 lb
AMB2SL8-1	Slotted	8 - 10	2 in	1	0.065 lb
AMB2SL8-25	Slotted	8 - 10	2 in	25	0.028 lb
AMB2SQ1-50	Square	#1	2 in	50	0.020 lb
AMB3BSQ1-25	Square	#1	3.5 in	25	0.046 lb
AMB6SQ1-25	Square	#1	6 in	25	0.052 lb
AMB2SQ2-1	Square	#2	2 in	1	0.055 lb
AMB2SQ2-5	Square	#2	2 in	5	0.160 lb
AMB2SQ2-50	Square	#2	2 in	50	0.025 lb
AMB3BSQ2-1	Square	#2	3.5 in	1	0.060 lb
AMB3BSQ2-25	Square	#2	3.5 in	25	0.046 lb
AMB6SQ2-25	Square	#2	6 in	25	0.082 lb
AMB2SQ3-50	Square	#3	2 in	50	0.026 lb
AMB3BSQ3-25	Square	#3	3.5 in	25	0.046 lb
AMB6SQ3-25	Square	#3	6 in	25	0.082 lb
AMB2TX15-2	Torx®	T15	2 in	2	0.060 lb
AMB2TX15-25	Torx®	T15	2 in	25	0.018 lb
AMB2TX20-2	Torx®	T20	2 in	2	0.045 lb
AMB2TX20-25	Torx®	T20	2 in	25	0.020 lb
AMB2TX25-2	Torx®	T25	2 in	2	0.075 lb

■ Continued on next page

Power Insert Bits ■ *Continued from previous page*

Cat. No.	Tip Style	Tip Size	Overall Length	Quantity Per Package	Product Weight
AMB2TX25-5	Torx®	T25	2 in	5	0.115 lb
AMB2TX25-50	Torx®	T25	2 in	50	0.023 lb
AMB3BTX25-1	Torx®	T25	3.5 in	1	0.055 lb
AMB3BTX25-25	Torx®	T25	3.5 in	25	0.035 lb
AMB6TX25-1	Torx®	T25	6 in	1	0.095 lb
AMB6TX25-25	Torx®	T25	6 in	25	0.056 lb
AMB2TX27-50	Torx®	T27	2 in	50	0.023 lb
AMB2TX30-2	Torx®	T30	2 in	2	0.060 lb
AMB2TX30-50	Torx®	T30	2 in	50	0.023 lb
AMB2TX40-2	Torx®	T40	2 in	2	0.105 lb
AMB2TX40-50	Torx®	T40	2 in	50	0.034 lb

Impact Drive Guides

- Full body design for greater strength and durability
- Optimized tip geometry for exact fastener fitment
- Helps to eliminate cam-out and promotes fastener retention
- Modified S2 steel and proprietary heat treat process maximizes bit life
- Laser markings for long-lasting quick and easy size identification



Cat. No.	Shank Diameter	Overall Length	Quantity Per Package	Product Weight
AMDG3-1	1/4 in	3 in	1	0.250 lb
AMDG3-25	1/4 in	3 in	25	0.081 lb

3 Pc. Magnetic Nutsetter Set

- Full body design for greater strength and durability
- Optimized tip geometry for exact fastener fitment
- Helps to eliminate cam-out and promotes fastener retention
- Modified S2 steel and proprietary heat treat process maximizes bit life
- Laser markings for long-lasting quick and easy size identification



Cat. No.	Included Storage	Product Weight
AMN1CSET-3	None	0.155 lb

Cat. No.	Description
AMN1C16	1/4" x 1-7/8" Magnetic Nutsetter
AMN1C20	5/16" x 1-7/8" Magnetic Nutsetter
AMN1C24	3/8" x 1-7/8" Magnetic Nutsetter

Magnetic Nutsetters

- Full body design for greater strength and durability
- Optimized tip geometry for exact fastener fitment
- Helps to eliminate cam-out and promotes fastener retention
- Modified S2 steel and proprietary heat treat process maximizes bit life
- Laser markings for long-lasting quick and easy size identification



Cat. No.	SAE/Metric	Size	Overall Length	Quantity Per Package	Product Weight
AMN1C16-1	SAE	1/4 in	1.875 in	1	0.050 lb
AMN1C16-25	SAE	1/4 in	1.875 in	25	0.042 lb
AMN2B16-1	SAE	1/4 in	2.56 in	1	0.070 lb
AMN2B16-25	SAE	1/4 in	2.56 in	25	0.063 lb
AMN616-25	SAE	1/4 in	6 in	25	0.153 lb
AMN1C20-1	SAE	5/16 in	1.875 in	1	0.060 lb
AMN1C20-25	SAE	5/16 in	1.875 in	25	0.048 lb
AMN2B20-1	SAE	5/16 in	2.56 in	1	0.085 lb
AMN2B20-25	SAE	5/16 in	2.56 in	25	0.075 lb
AMN620-25	SAE	5/16 in	6 in	25	0.158 lb
AMN1C24-1	SAE	3/8 in	1.875 in	1	0.060 lb
AMN1C24-25	SAE	3/8 in	1.875 in	25	0.056 lb
AMN2B24-1	SAE	3/8 in	2.56 in	1	0.090 lb
AMN2B24-25	SAE	3/8 in	2.56 in	25	0.081 lb
AMN624-25	SAE	3/8 in	6 in	25	0.167 lb
AMN1C28-1	SAE	7/16 in	1.875 in	1	0.065 lb
AMN1C28-25	SAE	7/16 in	1.875 in	25	0.056 lb
AMN2B28-1	SAE	7/16 in	2.56 in	1	0.110 lb
AMN2B28-25	SAE	7/16 in	2.56 in	25	0.102 lb
AMN1C32-1	SAE	1/2 in	1.875 in	1	0.075 lb
AMN1C32-25	SAE	1/2 in	1.875 in	25	0.070 lb
AMN2B32-1	SAE	1/2 in	2.56 in	1	0.140 lb
AMN2B32-25	SAE	1/2 in	2.56 in	25	0.136 lb

Quick Release Bit Holders

- Full body design for greater strength and durability
- Optimized tip geometry for exact fastener fitment
- Helps to eliminate cam-out and promotes fastener retention
- Modified S2 steel and proprietary heat treat process maximizes bit life
- Laser markings for long-lasting quick and easy size identification



Cat. No.	Shank Diameter	Overall Length	Quantity Per Package	Product Weight
AMBQ2A-1	1/4 in	2-1/4 in	1	0.045 lb
AMBQ2A-25	1/4 in	2-1/4 in	25	0.067 lb

INSERT BITS

NUTSETTERS

Magnetic Bit Holders

- Full body design for greater strength and durability
- Optimized tip geometry for exact fastener fitment
- Helps to eliminate cam-out and promotes fastener retention
- Modified S2 steel and proprietary heat treat process maximizes bit life
- Laser markings for long-lasting quick and easy size identification



Cat. No.	Shank Diameter	Overall Length	Quantity Per Package	Product Weight
AMBH2-25	1/4 in	2 in	25	0.039 lb
AMBH3-1	1/4 in	3 in	1	0.070 lb
AMBH3-25	1/4 in	3 in	25	0.081 lb

Extension Bit Holders

- Full body design for greater strength and durability
- Optimized tip geometry for exact fastener fitment
- Helps to eliminate cam-out and promotes fastener retention
- Modified S2 steel and proprietary heat treat process maximizes bit life
- Laser markings for long-lasting quick and easy size identification



Cat. No.	Shank Diameter	Overall Length	Quantity Per Package	Product Weight
AMBH6-1	1/4 in	6 in	1	0.120 lb
AMBH6-25	1/4 in	6 in	25	0.129 lb
AMBH12-1	1/4 in	12 in	1	0.225 lb
AMBH12-25	1/4 in	12 in	25	0.216 lb

Pliers

Z2 • Tongue & Groove • Solid Joint • Slip Joint • Compound Action • Locking • Specialty

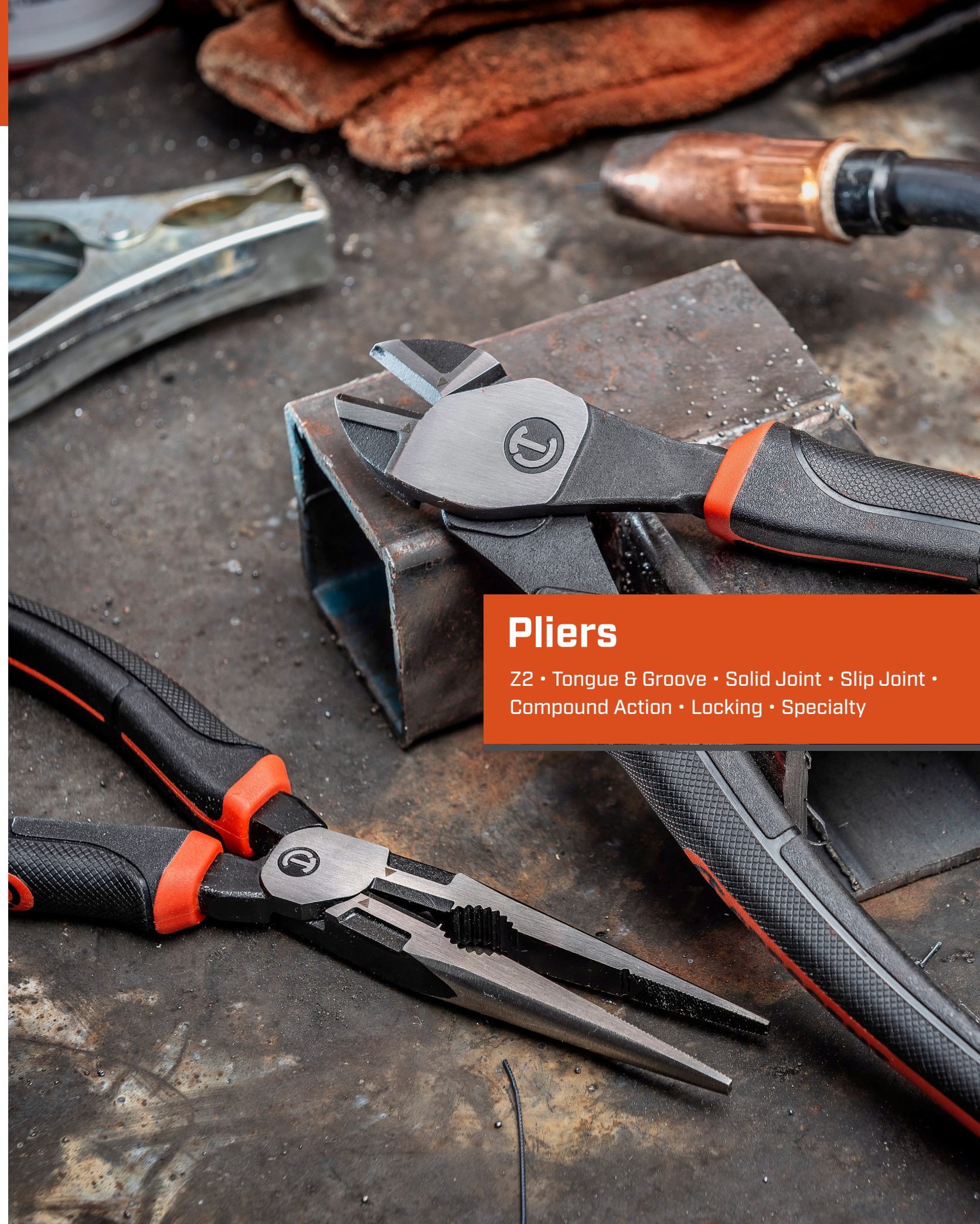

3 Pc. Z2 Auto-Bite™ Tongue & Groove Plier Set

- Patented Auto-Bite™ lever enables one handed jaw adjustment
- Thumb adjust Auto-Bite™ knob to engage or disengage Auto-Bite™ lever
- With the Auto-Bite™ lever engaged, simply squeeze the handles and the jaw automatically adjust to a precise grip
- Slim jaws provide 40% greater access
- Aggressive tooth design increases torque transfer
- 25 & 30 jaw positions for more flexibility, grip comfort and jaw capacity
- Grip Zone™ handles for non-marring grip
- V™ jaws and self-locking adjustment
- Ergonomic handles with tether point increase overall comfort and safety



Cat. No.	Included Storage	Product Weight
RTABCGSET3	None	3.285 lb

Cat. No.	Description
RTAB8CG	8" Z2 Auto-Bite™ Tongue & Groove Dual Material Pliers
RTAB10CG	10" Z2 Auto-Bite™ Tongue & Groove Dual Material Pliers
RTAB12CG	12" Z2 Auto-Bite™ Tongue & Groove Dual Material Pliers

2 Pc. Z2 Auto-Bite™ Tongue & Groove Plier Set

- Patented Auto-Bite™ lever enables one handed jaw adjustment
- Thumb adjust Auto-Bite™ knob to engage or disengage Auto-Bite™ lever
- With the Auto-Bite™ lever engaged, simply squeeze the handles and the jaw automatically adjust to a precise grip
- Slim jaws provide 40% greater access
- Aggressive tooth design increases torque transfer
- 25 & 30 jaw positions for more flexibility, grip comfort and jaw capacity
- Grip Zone™ handles for non-marring grip
- V™ jaws and self-locking adjustment
- Ergonomic handles with tether point increase overall comfort and safety



Cat. No.	Included Storage	Product Weight
RTABCGSET2	None	2.646 lb

Cat. No.	Description
RTAB10CG	10" Z2 Auto-Bite™ Tongue & Groove Dual Material Pliers
RTAB12CG	12" Z2 Auto-Bite™ Tongue & Groove Dual Material Pliers

Z2 Auto-Bite™ Tongue and Groove Pliers

True one handed automatic adjustment and slim design make these pliers perfect for work in cramped, hard to reach spaces. Just flip the patented Auto-Bite™ lever with your thumb and squeeze the handles to fit the jaws securely around any object. The Auto-Bite™ has an aggressive tooth design that grips tight for maximum turning power then releases just as easily.

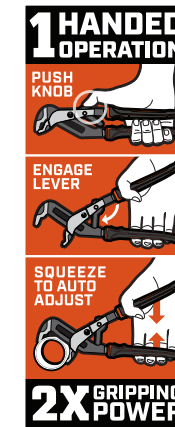

Thumb-Adjust Auto-Bite™ Knob
Engages/disengages Auto-Bite Lever

Ergonomic Dual Material Grips
With tether point increase overall comfort and safety
TETHER READY™

RTAB12CG

30 Jaw Positions
For more flexibility, grip comfort and jaw capacity

Grip Zone Handles
Non-marring grip

Patented Auto-Bite™ Lever
Enables one-handed jaw adjustment

Aggressive Tooth Design
Increases torque transfer

"V" Jaws
Allow for firmer grip on various shapes



Z2 Auto-Bite™ Tongue & Groove Dual Material Pliers

- Patented Auto-Bite™ lever enables one handed jaw adjustment
- Thumb adjust Auto-Bite™ knob to engage or disengage Auto-Bite™ lever
- With the Auto-Bite™ lever engaged, simply squeeze the handles and the jaw automatically adjust to a precise grip
- Slim jaws provide 40% greater access
- Aggressive tooth design increases torque transfer
- Grip Zone™ handles for non-marring grip
- V™ jaws and self-locking adjustment
- Ergonomic handles with tether point increase overall comfort and safety



Cat. No.	Jaw Positions	Overall Length	Jaw Length	Jaw Width	Jaw Thickness	Jaw Capacity	Wire Crimper	Wire Cutter	Product Weight
RTAB6CG	14	6.9 in	1 in	1 in	0.25 in	1.25 in	No	No	0.500 lb
RTAB8CG	20	8.7 in	1 in	1 in	0.28 in	1.85 in	No	No	0.600 lb
RTAB10CG	25	10.9 in	1.25 in	1.3 in	0.3 in	2.2 in	No	No	1.000 lb
RTAB12CG	30	12.8 in	2 in	1.8 in	0.35 in	2.75 in	No	No	1.700 lb

Z2 K9™ Straight Jaw Dipped Handle Tongue and Groove Pliers

- K9™ jaw design provides a strong grip, even when on a 35° angle
- Slim jaws provide 40% greater access
- Aggressive tooth design increases torque transfer
- 8 or 10 jaw positions for more flexibility, grip comfort and jaw capacity
- Ergonomic handles increase overall comfort
- Professional easy clean dipped grips



Cat. No.	Jaw Positions	Overall Length	Jaw Length	Jaw Width	Jaw Thickness	Jaw Capacity	Wire Crimper	Wire Cutter	Product Weight
RTZ28	8	8.1 in	1 in	1.1 in	0.33 in	1.6 in	No	No	0.545 lb
RTZ210	8	10.2 in	1.25 in	1.4 in	0.38 in	2.1 in	No	No	0.875 lb
RTZ212	8	12.1 in	1.8 in	1.85 in	0.42 in	2.6 in	No	No	1.525 lb
RTZ216	10	16.5 in	2.5 in	2.5 in	0.58 in	4.2 in	No	No	3.100 lb

Z2 K9™ V-Jaw Dipped Handle Tongue and Groove Pliers

- K9™ jaw design provides a strong grip, even when on a 35° angle
- Slim jaws provide 40% greater access
- Aggressive tooth design increases torque transfer
- 8 or 10 jaw positions for more flexibility, grip comfort and jaw capacity
- Ergonomic handles increase overall comfort
- Professional easy clean dipped grips
- V-jaws and self-locking adjustment



Cat. No.	Jaw Positions	Overall Length	Jaw Length	Jaw Width	Jaw Thickness	Jaw Capacity	Wire Crimper	Wire Cutter	Product Weight
RTZ28V	8	8.1 in	1 in	1.1 in	0.33 in	1.6 in	No	No	0.545 lb
RTZ210V	8	10.2 in	1.25 in	1.4 in	0.38 in	2.1 in	No	No	0.875 lb
RTZ212V	8	12.1 in	1.8 in	1.85 in	0.42 in	2.6 in	No	No	1.525 lb
RTZ216V	10	16.5 in	2.5 in	2.5 in	0.58 in	4.2 in	No	No	3.100 lb

3 Pc. Z2 K9™ Straight Jaw Dipped Handle Tongue and Groove Plier Set

- K9™ jaw design provides a strong grip, even when on a 35° angle
- Slim jaws provide 40% greater access
- Aggressive tooth design increases torque transfer
- 8 jaw positions for more flexibility, grip comfort and jaw capacity
- Ergonomic handles increase overall comfort
- Professional easy clean dipped grips



Cat. No.	Included Storage	Product Weight
RTZ2SET3	None	3.300 lb

Cat. No.	Description
RTZ28	8" Z2 K9™ Straight Jaw Dipped Handle Tongue and Groove Pliers
RTZ210	10" Z2 K9™ Straight Jaw Dipped Handle Tongue and Groove Pliers
RTZ212	12" Z2 K9™ Straight Jaw Dipped Handle Tongue and Groove Pliers

Z2

Z2

2 Pc. Z2 K9™ Straight Jaw Dual Material Tongue and Groove Plier Set

- K9™ jaw design provides a strong grip, even when on a 35° angle
- Slim jaws provide 40% greater access
- Aggressive tooth design increases torque transfer
- 8 jaw positions for more flexibility, grip comfort and jaw capacity
- Grip Zone™ handles for non-marring grip
- Ergonomic handles with tether point increase overall comfort and safety



Cat. No.	Included Storage	Product Weight
RTZ2CGSET2	None	2.300 lb

Cat. No.	Description
RTZ28CG	8" Z2 K9™ Straight Jaw Dual Material Tongue and Groove Pliers
RTZ212CG	12" Z2 K9™ Straight Jaw Dual Material Tongue and Groove Pliers

2 Pc. Z2 K9™ V-Jaw Dual Material Tongue and Groove Plier Set

- K9™ jaw design provides a strong grip, even when on a 35° angle
- Slim jaws provide 40% greater access
- Aggressive tooth design increases torque transfer
- 8 jaw positions for more flexibility, grip comfort and jaw capacity
- Grip Zone™ handles for non-marring grip
- Ergonomic handles with tether point increase overall comfort and safety
- V-jaws and self-locking adjustment



Cat. No.	Included Storage	Product Weight
RTZ2CGVSET2	None	2.600 lb

Cat. No.	Description
RTZ210CGV	10" Z2 K9™ V-Jaw Dual Material Tongue and Groove Pliers
RTZ212CGV	12" Z2 K9™ V-Jaw Dual Material Tongue and Groove Pliers

Z2 K9™ Straight Jaw Dual Material Tongue and Groove Pliers

- K9™ jaw design provides a strong grip, even when on a 35° angle
- Slim jaws provide 40% greater access
- Aggressive tooth design increases torque transfer
- 8 jaw positions for more flexibility, grip comfort and jaw capacity
- Grip Zone™ handles for non-marring grip
- Ergonomic handles with tether point increase overall comfort and safety



Cat. No.	Jaw Positions	Overall Length	Jaw Length	Jaw Width	Jaw Thickness	Jaw Capacity	Wire Crimper	Wire Cutter	Product Weight
RTZ28CG	8	8.5 in	1 in	1.1 in	0.33 in	1.6 in	No	No	0.545 lb
RTZ210CG	8	10.8 in	1.25 in	1.4 in	0.38 in	2.1 in	No	No	0.875 lb
RTZ212CG	8	12.8 in	1.8 in	1.85 in	0.42 in	2.6 in	No	No	1.525 lb

Z2 K9™ V-Jaw Dual Material Tongue and Groove Pliers

- K9™ jaw design provides a strong grip, even when on a 35° angle
- Slim jaws provide 40% greater access
- Aggressive tooth design increases torque transfer
- 8 jaw positions for more flexibility, grip comfort and jaw capacity
- Grip Zone™ handles for non-marring grip
- Ergonomic handles with tether point increase overall comfort and safety
- V-jaws and self-locking adjustment



Cat. No.	Jaw Positions	Overall Length	Jaw Length	Jaw Width	Jaw Thickness	Jaw Capacity	Wire Crimper	Wire Cutter	Product Weight
RTZ28CGV	8	8.5 in	1 in	1.1 in	0.33 in	1.6 in	No	No	0.545 lb
RTZ210CGV	8	10.8 in	1.25 in	1.4 in	0.38 in	2.1 in	No	No	0.875 lb
RTZ212CGV	8	12.8 in	1.8 in	1.85 in	0.42 in	2.6 in	No	No	1.525 lb

Z2

Z2

5 Pc. Z2 Mixed Dual Material Plier Set

- K9™ jaw design provides a strong grip, even when on a 35° angle
- Slim jaws provide 40% greater access
- Aggressive tooth design increases torque transfer
- 8 jaw positions for more flexibility, grip comfort and jaw capacity
- Ergonomic handles increase overall comfort
- High leverage joint design provides up to 35% greater cutting power
- Laser hardened cutting edges cut clean and remain sharp 50% longer
- Cross hatched jaw for gripping and pulling
- Fastener grip area for turning nuts and bolts
- Ergonomic handles with tether point increase overall comfort and safety



Cat. No.	Included Storage	Product Weight
Z2SET5CG	None	4.000 lb

Cat. No.	Description	Cat. No.	Description
HTZ28CG	8" Z2 Dual Material Slip Joint Pliers	Z20509CG	9-1/2" Z2 Dual Material Lineman's Pliers
Z6548CG	8" Z2 Dual Material Long Nose Pliers	RTZ210CG	10" Z2 K9™ Straight Jaw Dual Material Tongue and Groove Pliers
Z5428CG	8" Z2 Dual Material Diagonal Cutting Pliers		

3 Pc. Z2 Mixed Dual Material Plier Set

- K9™ jaw design provides a strong grip, even when on a 35° angle
- Slim jaws provide 40% greater access
- Aggressive tooth design increases torque transfer
- 8 jaw positions for more flexibility, grip comfort and jaw capacity
- Ergonomic handles increase overall comfort
- High leverage joint design provides up to 35% greater cutting power
- Laser hardened cutting edges cut clean and remain sharp 50% longer
- Cross hatched jaw for gripping and pulling
- Fastener grip area for turning nuts and bolts
- Ergonomic handles with tether point increase overall comfort and safety



Cat. No.	Included Storage	Product Weight
Z2SET3CG	None	2.510 lb

Cat. No.	Description
Z6548CG	8" Z2 Dual Material Long Nose Pliers
Z20508CG	8" Z2 Dual Material Lineman's Pliers
RTZ210CG	10" Z2 K9™ Straight Jaw Dual Material Tongue and Groove Pliers

Z2 Dipped Handle Diagonal Cutting Pliers

- High leverage joint design provides up to 35% greater cutting power
- Laser hardened cutting edges cut clean and remain sharp 50% longer
- 20° head angle for true flush cutting
- Professional easy clean dipped grips



Cat. No.	Overall Length	Jaw Length	Jaw Thickness	Edge Type/ Cut Capacity	Jaw Capacity	Cutting Edge Length	Product Weight
Z5426	6.1 in	0.75 in	0.4 in	KNIFE-KNIFE / AWG 8	0.75 in	0.75 in	0.450 lb
Z5428	8.1 in	0.75 in	0.53 in	KNIFE-KNIFE / AWG 7	0.75 in	0.75 in	0.650 lb

Z2 Dual Material Diagonal Cutting Pliers

- High leverage joint design provides up to 35% greater cutting power
- Laser hardened cutting edges cut clean and remain sharp 50% longer
- 20° head angle for true flush cutting
- Ergonomic handles with tether point increase overall comfort and safety



Cat. No.	Overall Length	Jaw Length	Jaw Thickness	Edge Type/ Cut Capacity	Jaw Capacity	Cutting Edge Length	Product Weight
Z5426CG	6.5 in	0.75 in	0.4 in	KNIFE-KNIFE / AWG 8	0.75 in	0.75 in	0.500 lb
Z5428CG	8.6 in	0.75 in	0.53 in	KNIFE-KNIFE / AWG 7	0.75 in	0.75 in	0.700 lb

Z2 Dipped Handle Long Nose Pliers

- High leverage joint design provides up to 35% greater cutting power
- Laser hardened cutting edges cut clean and remain sharp 50% longer
- Cross hatched jaw for gripping and pulling
- Fastener grip area for turning nuts and bolts
- Professional easy clean dipped grips



Cat. No.	Overall Length	Jaw Length	Jaw Width	Jaw Thickness	Edge Type/ Cut Capacity	Jaw Capacity	Product Weight
Z6546	6.2 in	2 in	0.12 in	0.37 in	KNIFE-KNIFE / AWG 11	1.5 in	0.250 lb
Z6548	8.1 in	3 in	0.16 in	0.38 in	KNIFE-KNIFE / AWG 11	2 in	0.400 lb

Z2 Long Nose Pliers

Like other pliers in the Z2 line, these offer outstanding cutting ability due to their pivot-forward high leverage joint design. With laser-hardened cutting edges, they offer 50% longer life. And they are the only long nose pliers that feature a “Six Zone” head for exceptional gripping, cutting, wire pulling, nail holding, fastener turning, and non-marring capabilities.



Dipped Grip Option:
Ergonomic, easy clean dipped grips

LONGEST CUT LIFE
50%+
GOOD BETTER BEST

EASY CUTTING
35%+
GOOD BETTER BEST

LASER HARDENED
EDGES STAY SHARP

SIX ZONE HEAD
1. Cross Hatch Jaw
2. Wire Puller Notch
3. Non-Marring Grip
4. Torque Zone
5. Fastener Grip Area
6. Cut Zone

Z2 Dual Material Long Nose Pliers

- High leverage joint design provides up to 35% greater cutting power
- Laser hardened cutting edges cut clean and remain sharp 50% longer
- Cross hatched jaw for gripping and pulling
- Fastener grip area for turning nuts and bolts
- Ergonomic handles with tether point increase overall comfort and safety



Cat. No.	Overall Length	Jaw Length	Jaw Width	Jaw Thickness	Edge Type/ Cut Capacity	Jaw Capacity	Product Weight
Z6546CG	6.6 in	2 in	0.12 in	0.37 in	KNIFE-KNIFE / AWG 11	1.5 in	0.300 lb
Z6548CG	8.5 in	3 in	0.16 in	0.38 in	KNIFE-KNIFE / AWG 11	2 in	0.450 lb

Z2 Dipped Handle Lineman's Pliers

- High leverage joint design provides up to 35% greater cutting power
- Laser hardened cutting edges cut clean and remain sharp 50% longer
- Cross hatched jaw for gripping and pulling
- Fish tape channel for use with flat steel tapes
- Professional easy clean dipped grips



Cat. No.	Overall Length	Jaw Length	Jaw Width	Jaw Thickness	Edge Type/ Cut Capacity	Jaw Capacity	Product Weight
Z20508	8.4 in	1.5 in	0.28 in	0.53 in	KNIFE-KNIFE / AWG 6	1.5 in	0.900 lb
Z20509	9.1 in	1.6 in	0.31 in	0.62 in	KNIFE-KNIFE / AWG 5	1.6 in	1.100 lb

Z2 Dual Material Lineman's Pliers

- High leverage joint design provides up to 35% greater cutting power
- Laser hardened cutting edges cut clean and remain sharp 50% longer
- Cross hatched jaw for gripping and pulling
- Fish tape channel for use with flat steel tapes
- Ergonomic handles with tether point increase overall comfort and safety



Cat. No.	Overall Length	Jaw Length	Jaw Width	Jaw Thickness	Edge Type/ Cut Capacity	Jaw Capacity	Product Weight
Z20508CG	8.9 in	1.5 in	0.28 in	0.53 in	KNIFE-KNIFE / AWG 6	1.5 in	0.950 lb
Z20509CG	9.6 in	1.6 in	0.31 in	0.62 in	KNIFE-KNIFE / AWG 5	1.6 in	1.200 lb

Z2 Lineman's Pliers

These are Crescent's best cutting lineman's pliers ever with a pivot-forward high-leverage joint design that lowers force required to cut by 35%, reducing hand fatigue on repetitive cuts. Combine that with laser-hardened cutting edges that provide 50% longer cutting life and you have tools made for the high demands of professional tradespeople.



Dipped Grip Option:
Ergonomic, easy clean dipped grips



Z2 Dipped Handle Slip Joint Pliers

- Curved jaws design for gripping and turning round objects such as pipes, rods and pins
- Fastener grip area for turing nuts and bolts
- Cross hatched jaw for gripping and pulling
- Deep integrated wire cutter reduces cutting effort
- Professional easy clean dipped grips



Cat. No.	Application	Overall Length	Jaw Length	Jaw Thickness	Jaw Capacity	Product Weight
HTZ26	Gripping	6.38 in	1.35 in	0.42 in	1.25 in	0.415 lb
HTZ28	Gripping	8.1 in	1.35 in	0.42 in	1.5 in	0.645 lb

Z2 Dual Material Slip Joint Pliers

- Curved jaws design for gripping and turning round objects such as pipes, rods and pins
- Fastener grip area for turing nuts and bolts
- Integrated non-marring Grip Zone™ pipe grip area in the handle, made of high-impact rubber
- Cross hatched jaw for gripping and pulling
- Deep integrated wire cutter reduces cutting effort



Cat. No.	Application	Overall Length	Jaw Length	Jaw Thickness	Jaw Capacity	Product Weight
HTZ26CG	Gripping	6.75 in	1.35 in	0.42 in	1.25 in	0.415 lb
HTZ28CG	Gripping	8.65 in	1.35 in	0.42 in	1.5 in	0.645 lb

2 Pc. Grip Zone™ V-Jaw Dual Material Tongue & Groove Plier Set

- V-shaped jaws allow for a firmer grip on various shapes
- Rivet construction with precision machined joint interlock assures smooth, positive joint action, no chance of slipping position or coming apart under load
- Unique tooth design grips tighter, giving you increased torque using less effort
- Angled teeth for increased grip on pipes and fasteners
- Integrated non-marring Grip Zone™ pipe grip area in the handle, made of high-impact rubber
- Maximum durability from alloy steel construction with induction-hardened teeth
- Black oxide finish wipes clean easily and resists corrosion



Cat. No.	Included Storage	Product Weight
RT400SGSET2	None	2.640 lb

Cat. No.	Description
RT410SGVN	10" Grip Zone™ V-Jaw Dual Material Tongue & Groove Pliers
RT412SGVN	12" Grip Zone™ V-Jaw Dual Material Tongue & Groove Pliers

Grip Zone™ V-Jaw Dual Material Tongue & Groove Pliers

- V-shaped jaws allow for a firmer grip on various shapes
- Rivet construction with precision machined joint interlock assures smooth, positive joint action, no chance of slipping position or coming apart under load
- Unique tooth design grips tighter, giving you increased torque using less effort
- Angled teeth for increased grip on pipes and fasteners
- Integrated non-marring Grip Zone™ pipe grip area in the handle, made of high-impact rubber
- Maximum durability from alloy steel construction with induction-hardened teeth
- Black oxide finish wipes clean easily and resists corrosion



Cat. No.	Jaw Positions	Overall Length	Jaw Length	Jaw Width	Jaw Thickness	Jaw Capacity	Wire Crimper	Wire Cutter	Product Weight
RT410SGVN	6	10 in	1.57 in	1.67 in	0.46 in	1.99 in	No	No	0.870 lb
RT412SGVN	8	12 in	2.02 in	2.06 in	0.50 in	2.51 in	No	No	1.485 lb

Straight Jaw Dipped Handle Tongue and Groove Pliers

- Rivet construction with precision machined joint interlock assures smooth, positive joint action, no chance of slipping position or coming apart under load
- Self-locking jaw opening adjustment
- Alloy steel construction with induction-hardened teeth for maximum durability
- Long handles provide additional leverage
- Secure grip from the single-dip handles that easily wipe clean
- Black oxide finish to prevent corrosion



Cat. No.	Jaw Positions	Overall Length	Jaw Length	Jaw Width	Jaw Thickness	Jaw Capacity	Wire Crimper	Wire Cutter	Product Weight
RT27CVN	6	7 in	0.88 in	1.06 in	0.31 in	1.25 in	No	No	0.500 lb
RT210CVN	6	10 in	1.07 in	1.33 in	0.30 in	1.66 in	No	No	0.820 lb
RT212CVN	8	12 in	1.62 in	1.74 in	0.36 in	2.25 in	No	No	1.465 lb
RT216CVN	10	16 in	2.55 in	2.5 in	0.50 in	4.5 in	No	No	3.110 lb

3 Pc. Straight Jaw Dipped Handle Tongue and Groove Plier Set

- Rivet construction with precision machined joint interlock assures smooth, positive joint action, no chance of slipping position or coming apart under load
- Self-locking jaw opening adjustment
- Alloy steel construction with induction-hardened teeth for maximum durability
- Long handles provide additional leverage
- Secure grip from the single-dip handles that easily wipe clean
- Black oxide finish to prevent corrosion



Cat. No.	Included Storage	Product Weight
RT200SET3	None	3.015 lb

Cat. No.	Description
RT27CVN	7" Straight Jaw Dipped Handle Tongue and Groove Pliers
RT210CVN	10" Straight Jaw Dipped Handle Tongue and Groove Pliers
RT212CVN	12" Straight Jaw Dipped Handle Tongue and Groove Pliers

V-Jaw Dipped Handle Tongue and Groove Pliers

- V-shaped jaws with an offset, self-locking adjustment grip tightly in any configuration
- Rivet construction with precision-machined joint interlock assures smooth, positive joint action with no chance of slipping position or coming apart under load
- Unique tooth design grips tighter and provides increased torque with less effort
- Maximum durability from alloy steel construction with induction-hardened teeth
- Secure grip from the single-dip handles that easily wipe clean
- Black oxide finish to prevent corrosion



Cat. No.	Jaw Positions	Overall Length	Jaw Length	Jaw Width	Jaw Thickness	Jaw Capacity	Wire Crimper	Wire Cutter	Product Weight
RT410CVN	6	9.75 in	1 in	1.25 in	0.31 in	1.812 in	No	No	.816 lb
RT412CVN	8	12 in	1.75 in	1.65 in	0.38 in	3 in	No	No	1.560 lb

TONGUE & GROOVE

TONGUE & GROOVE

Mini V-Jaw Dipped Handle Tongue and Groove Pliers

- V-shaped jaws with an offset, self-locking adjustment grip tightly in any configuration
- Rivet construction with precision-machined joint interlock assures smooth, positive joint action with no chance of slipping position or coming apart under load
- Unique tooth design grips tighter and provides increased torque with less effort
- Maximum durability from alloy steel construction with induction-hardened teeth
- Four jaw positions for flexibility and comfort
- Secure grip from the single-dip handles that easily wipe clean
- Black oxide finish to prevent corrosion



Cat. No.	Jaw Positions	Overall Length	Jaw Length	Jaw Width	Jaw Thickness	Jaw Capacity	Wire Crimper	Wire Cutter	Product Weight
RT24CVS	4	4.9 in	0.50 in	0.75 in	0.22 in	0.75 in	No	No	0.145 lb

Heavy-Duty Dipped Handle Diagonal Cutting Pliers

- Designed for heavy-duty wire cutting
- Standard or flush cutting edges
- Angled head for offset cutting
- Electronically induction hardened hand-honed, long lasting cutting edges
- Manufactured from forged alloy tool steel for durability
- Dipped handle grips for easy cleaning and better control
- Polished head resists rust and corrosion



Cat. No.	Overall Length	Jaw Length	Jaw Width	Jaw Thickness	Edge Type/Cut Capacity	Jaw Capacity	Wire Crimper	Product Weight
5427CVNN	7 in	0.78 in	1.218 in	0.468 in	Std./12 AWG	0.4 in	No	0.685 lb
5428CVNN	8 in	0.78 in	1.218 in	0.468 in	Std./22 AWG	0.4 in	No	0.74 lb
5437CENN	7 in	0.78 in	1.218 in	0.468 in	Flush/22 AWG	0.4 in	No	0.635 lb
5438CENN	8 in	0.78 in	1.218 in	0.468 in	Flush/12 AWG	0.4 in	No	0.70 lb

General Purpose Diagonal Cutting Pliers

- Designed for general wire cutting in confined spaces
- Long cutting edges for harder wires
- Electronically induction hardened hand-honed, long lasting cutting edges
- Manufactured from forged alloy tool steel for durability
- Polished head resists rust and corrosion



Cat. No.	Handle Material	Overall Length	Jaw Length	Jaw Width	Jaw Thickness	Edge Type/Cut Capacity	Jaw Capacity	Wire Crimper	Product Weight
9336NN	Alloy Steel	6 in	0.81 in	0.75 in	0.437 in	Std./12 AWG	0.4 in	No	0.335 lb
9336CVNN	Double Dip	6 in	0.81 in	0.75 in	0.437 in	Std./12 AWG	0.4 in	No	0.410 lb
9337CVNN	Double Dip	7 in	1 in	0.906 in	0.468 in	Std./12 AWG	0.5 in	No	0.580 lb

Dipped Handle Long Needle Nose Pliers

- Long needle nose with excellent gripping ability
- Designed for work in tight, narrow areas
- Manufactured from forged alloy tool steel for durability
- Polished head resists rust and corrosion
- Dipped handle grips for easy cleaning and better control



Cat. No.	Overall Length	Jaw Length	Jaw Width	Jaw Thickness	Jaw Capacity	Wire Crimper	Wire Cutter	Product Weight
7776CVNN	6.5 in	2.062 in	0.687 in	0.343 in	1.1 in	No	No	0.320 lb
7777CVNN	7.46 in	2.687 in	0.687 in	0.328 in	1.4 in	No	No	0.350 lb

Dipped Handle Bent Needle Nose Pliers

- Designed for working in out-of-the-way confined corners
- Thin bent nose, tempered tips are made to bend slightly when gripping, returning to normal when pressure is released
- Manufactured from forged alloy tool steel for durability
- Polished head resists rust and corrosion
- Dipped handle grips for easy cleaning and better control

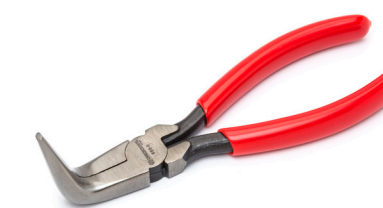

Cat. No.	Overall Length	Jaw Length	Jaw Width	Jaw Thickness	Jaw Capacity	Wire Crimper	Wire Cutter	Product Weight
8886CVNN	6.6 in	1 in	0.687 in	0.375 in	0.50 in	No	No	0.46 lb

SOLID JOINT

SOLID JOINT

High Leverage Lineman's Pliers

- Designed for electrical work
- Cutting edges cut clean and remain sharp
- Electronically induction hardened hand-honed, long lasting cutting edges
- Manufactured from forged alloy tool steel for durability
- Streamlined head design allows easy sliding in and out of belt loops
- Polished head resists rust and corrosion



Cat. No.	Handle Material	Overall Length	Jaw Length	Jaw Width	Jaw Thickness	Edge Type/Cut Capacity	Jaw Capacity	Wire Crimper	Product Weight
20509CVSMLNN	Double Dip	9.25 in	1.562 in	1.28 in	0.625 in	Std./11 AWG	0.70 in	No	1.170 lb
20509NN	Alloy Steel	9.25 in	1.562 in	1.28 in	0.625 in	Std./11 AWG	0.70 in	No	1.100 lb

Heavy-Duty End Cutting Nipper Pliers

- Strong and lightweight for demanding construction use
- Electronically induction hardened hand-honed, long lasting cutting edges
- Manufactured from forged alloy tool steel for durability
- Black finish with polished head resists rust and corrosion
- High leverage design to cut large diameter nails and wire



Cat. No.	Overall Length	Jaw Length	Jaw Width	Jaw Thickness	Edge Type/Cut Capacity	Jaw Capacity	Wire Crimper	Product Weight
GG010HNN	10 in	0.64 in	2.156 in	0.578 in	Std./12 AWG	0.50 in	No	1.04 lb
GG014HNN	14 in	0.718 in	1.656 in	0.64 in	Std./12 AWG	0.60 in	No	2.15 lb

Dipped Handle Lineman's Side Cutting Pliers

- Designed for electrical work
- Electronically induction hardened hand-honed, long lasting cutting edges
- Manufactured from forged alloy tool steel for durability
- Polished head resists rust and corrosion
- Spring tempered handles with dipped grips



Cat. No.	Overall Length	Jaw Length	Jaw Width	Jaw Thickness	Edge Type/Cut Capacity	Jaw Capacity	Wire Crimper	Product Weight
507CVNN	7.25 in	1.281 in	1 in	0.50 in	Std./12 AWG	0.60 in	No	0.660 lb
508CVNN	8.31 in	1.468 in	1.125 in	0.562 in	Std./11 AWG	0.70 in	No	1.025 lb

Dipped Handle End Cutting Nipper Pliers

- Manufactured from forged alloy tool steel for durability
- Electronically induction hardened hand-honed, long lasting cutting edges
- Thin throat and flush rivet size for improved access
- Dipped handles designed with a high leverage ratio for easier cutting
- Polished, durable forged alloy tool steel head



Cat. No.	Overall Length	Jaw Length	Jaw Width	Jaw Thickness	Edge Type/Cut Capacity	Jaw Capacity	Wire Crimper	Product Weight
727CVN	7.25 in	0.375 in	1.75 in	0.53 in	Std./12 AWG	0.40 in	No	0.815 lb
728CVNN	8.25 in	0.375 in	1.75 in	0.53 in	Std./12 AWG	0.60 in	No	0.905 lb
729CVNN	9.25 in	0.406 in	1.75 in	0.59 in	Std./12 AWG	0.60 in	No	0.980 lb

Button Pliers Fence Tool

- Designed for construction and maintenance of wire fencing
- Flat nose with three wire cutters, pipe grips, and teeth in extreme tip of nose
- Electronically induction hardened hand-honed, long lasting cutting edges
- Manufactured from forged alloy tool steel for durability
- Black finish with polished head resists rust and corrosion
- Knurled handles for better grip



Cat. No.	Overall Length	Jaw Length	Jaw Width	Jaw Thickness	Edge Type/Cut Capacity	Jaw Capacity	Product Weight
10008VNN	8 in	1.281 in	1.375 in	0.562 in	Std./12 AWG	0.70 in	0.860 lb
100010VNN	10.25 in	1.5 in	1.562 in	0.625 in	Std./11 AWG	0.70 in	1.335 lb

Dipped Handle Long Chain Nose Pliers

- Designed for work in confined areas
- Long chain nose with serrated jaws to easily make wire loops and bends
- Electronically induction hardened hand-honed, long lasting cutting edges
- Manufactured from forged alloy tool steel for durability
- Polished head resists rust and corrosion
- Dipped handle grips for easy cleaning and better control

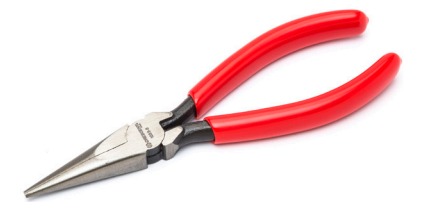

Cat. No.	Overall Length	Jaw Length	Jaw Width	Jaw Thickness	Jaw Capacity	Wire Crimper	Product Weight
10336CVNN	6.625 in	1.875 in	0.687 in	0.375 in	0.80 in	No	0.390 lb
10337CVNN	7.5 in	1.656 in	0.75 in	0.375 in	1 in	No	0.430 lb

SOLID JOINT

SOLID JOINT

Long Side Cutting Chain Nose Pliers

- Designed for reaching confined areas
- Long chain nose with fine serrated jaws to easily make wire loops and bends
- Electronically induction hardened hand-honed, long lasting cutting edges
- Manufactured from forged alloy tool steel for durability
- Polished head resists rust and corrosion



Cat. No.	Handle Material	Overall Length	Jaw Length	Jaw Width	Jaw Thickness	Edge Type/Cut Capacity	Jaw Capacity	Wire Crimper	Product Weight
6546NN	Alloy Steel	6.625 in	1.875 in	0.687 in	0.375 in	Std./14 AWG	0.80 in	No	0.315 lb
6546CVSMLNN	Double Dip	6.625 in	1.875 in	0.687 in	0.375 in	Std./14 AWG	0.80 in	No	0.380 lb
6547CVNN	Double Dip	7.5 in	1.656 in	0.75 in	0.375 in	Std./14 AWG	1 in	No	0.415 lb

Heavy-Duty Solid Joint Fence Tool Pliers

- Designed for heavy-duty wire cutting
- Standard or flush cutting edges
- Angled head for offset cutting
- Electronically induction hardened hand-honed, long lasting cutting edges
- Manufactured from forged alloy tool steel for durability
- Polished head resists rust and corrosion



Cat. No.	Handle Material	Overall Length	Edge Type/Cut Capacity	Wire Cutter	Product Weight
193610CVSMNN	Double Dip	10.437 in	Std./11 AWG	Yes	1.835 lb
193610VNN	Alloy Steel	10.437 in	Std./11 AWG	Yes	1.765 lb

Electrical Connector Pliers

- Fits A-N electrical connectors
- Three adjustment positions
- Replacement insert kit available 52910KITN



Cat. No.	Overall Length	Jaw Length	Jaw Width	Jaw Thickness	Jaw Capacity	Wire Crimper	Wire Cutter	Rplc. Part	Product Weight
52910N	10 in	1.6 in (inside) 2.53 in (outside)	1.5 in	0.375 in	0.75 in - 2.5 in	No	No	52910KITN	0.70 lb

Cee Tee Co.® Curved Jaw Slip Joint Pliers

- Curved jaws with hardened teeth for gripping and turning round objects such as pipes, rods and pins
- Flat jaw tips with hardened teeth for general purpose gripping
- Wire cutter positioned very close to the pivot to provide maximum leverage and powerful cutting
- Forged from accurately machined, hardened and tempered alloy steel
- Nickel chrome plated finish
- Non-slip textured handles for improved grip
- Two different locking jaw positions



Cat. No.	Overall Length	Jaw Length	Jaw Width	Jaw Thickness	Jaw Capacity	Wire Crimper	Wire Cutter	Packaging	Product Weight
H26VN	6.5 in	1.32 in	1.06 in	0.39 in	1 in	No	Yes	Carded	0.50 lb
H26N	6.5 in	1.32 in	1.12 in	0.39 in	1 in	No	Yes	Boxed	0.45 lb
H28VN	8 in	1.35 in	1.12 in	0.39 in	1 in	No	Yes	Carded	0.65 lb
H28N	8 in	1.35 in	1.12 in	0.39 in	1 in	No	Yes	Boxed	0.60 lb

2 Pc. Pro Series Dual Material Compound Action Cutting Plier Set

- Co-molded grips for added comfort
- Compound leverage design increases cutting and gripping pressure by 50%
- Chrome vanadium steel for increased durability
- Heat-treated joint rivet for smooth and consistent operation
- Induction-hardened edges for a long cutting life
- 1/3 lighter than standard pliers for reduced fatigue



Cat. No.	Included Storage	Product Weight
PSCA2SET	None	1.350 lb

Cat. No.	Description
PS5429C	8" Pro Series Dual Material Diagonal Compound Action Cutting Pliers
PS20509C	8" Pro Series Dual Material Lineman's Compound Action Cutting Pliers

SLIP JOINT

COMPOUND ACTION

Pro Series Dual Material Diagonal Compound Action Cutting Pliers

- Co-molded grips for added comfort
- Compound leverage design increases cutting and gripping pressure by 50%
- Chrome vanadium steel for increased durability
- Heat-treated joint rivet for smooth and consistent operation
- Induction-hardened edges for a long cutting life
- 1/3 lighter than standard pliers for reduced fatigue



Cat. No.	Overall Length	Jaw Length	Jaw Width	Jaw Thickness	Edge Type/Cut Capacity	Jaw Capacity	Wire Crimper	Product Weight
PS5429C	8 in	1 in	1 in	0.437 in	Std./11 AWG	0.50 in	No	0.50 lb

Pivot Action Dual Material Diagonal Compound Action Cutting Pliers

- Unique pivoting design cuts with 40% less force
- Compound design puts more force behind the cutting edge compared to traditional pliers
- Forged steel body is durable and strong
- Induction-hardened cutting edge for a long blade life
- Durable dual-material grips for added ergonomic comfort
- Anti-rust coating
- Designed with standard bevel edges for general wire cutting



Cat. No.	Overall Length	Jaw Length	Jaw Width	Jaw Thickness	Jaw Capacity	Wire Crimper	Cutting Edge Length	Product Weight
CCA5428	8 in	1.06 in	1.2 in	0.55 in	0.50 in	No	1.06 in	0.80 lb

Pro Series Dual Material Long Nose Compound Action Cutting Pliers

- Co-molded grips for added comfort
- Compound leverage design increases cutting and gripping pressure by 50%
- Chrome vanadium steel for increased durability
- Heat-treated joint rivet for smooth and consistent operation
- Induction-hardened edges for a long cutting life
- 1/3 lighter than standard pliers for reduced fatigue



Cat. No.	Overall Length	Jaw Length	Jaw Width	Jaw Thickness	Edge Type/Cut Capacity	Jaw Capacity	Wire Crimper	Product Weight
PS6549C	9 in	1.562 in	1.28 in	0.625 in	Std./11 AWG	0.80 in	No	0.60 lb

Pivot Action Dual Material Lineman's Compound Action Pliers

- Unique pivoting design cuts with 40% less force
- Compound design puts more force behind the cutting edge compared to traditional pliers
- Forged steel body is durable and strong
- Machined cross-check knurling pattern on the serrated jaw for a non-slip grip
- Induction-hardened cutting edge for a long blade life
- Durable dual-material grips for added ergonomic comfort
- Anti-rust coating
- Designed with standard bevel edges for general wire cutting



Cat. No.	Overall Length	Jaw Length	Jaw Width	Jaw Thickness	Jaw Capacity	Wire Crimper	Cutting Edge Length	Product Weight
CCA20509	9 in	1.65 in	1.3 in	0.55 in	.65 in	No	0.83 in	1.02 lb

Pro Series Dual Material Lineman's Compound Action Cutting Pliers

- Co-molded grips for added comfort
- Compound leverage design increases cutting and gripping pressure by 50%
- Chrome vanadium steel for increased durability
- Heat-treated joint rivet for smooth and consistent operation
- Induction-hardened edges for a long cutting life
- 1/3 lighter than standard pliers for reduced fatigue



Cat. No.	Overall Length	Jaw Length	Jaw Width	Jaw Thickness	Edge Type/Cut Capacity	Jaw Capacity	Wire Crimper	Product Weight
PS20509C	8 in	1.312 in	1 in	0.437 in	Std./11 AWG	0.65 in	No	0.60 lb

COMPOUND ACTION

COMPOUND ACTION

2 Pc. X2™ Straight and Bent Long Nose Dual Material Plier Set

- Long reach pliers for better access in tight spaces
- Double joint design allows the jaws to open a greater distance than the handle
- Compound joint opens wider with less effort
- Flush rivets are stronger and have a thinner profile
- Dual material handles offer a more comfortable grip
- Milled grooves in the tips grip fasteners and other objects tightly
- Made from corrosion-resistant alloy steel



Cat. No.	Included Storage	Product Weight
PSX204C	None	2.00 lb

Cat. No.	Description
PSX200C	13" X2™ Dual Material Long Reach Pliers
PSX201C	13" X2™ Dual Material Long Reach Bent Nose Pliers

X2™ Dual Material Long Reach Pliers

- Long reach pliers for better access in tight spaces
- Double joint design allows the jaws to open a greater distance than the handle
- Compound joint opens wider with less effort
- Flush rivets are stronger and have a thinner profile
- Dual-material grips for improved ergonomics and comfort
- Milled grooves in the tips grip fasteners and other objects tightly
- Made from corrosion-resistant alloy steel



Cat. No.	Overall Length	Jaw Length	Jaw Capacity	Wire Crimper	Wire Cutter	Product Weight
PSX200C	13.468 in	2.75 in	1.4 in	No	No	0.87 lb

X2™ Dual Material Long Reach Bent Nose

- Designed for working in out-of-the-way confined corners
- Double joint design allows the jaws to open a greater distance than the handle
- Compound joint opens wider with less effort
- Flush rivets are stronger and have a thinner profile
- Dual-material grips for improved ergonomics and comfort
- Milled grooves in the tips grip fasteners and other objects tightly
- Made from corrosion-resistant alloy steel



Cat. No.	UPC No.	Packaging	Application	Overall Length	Jaw Length	Jaw Width	Jaw Thickness	Jaw Capacity	Wire Crimper	Wire Cutter	Product Weight
PSX201C	037103241801	Carded	Gripping	13.265 in	2.5 in	0.359 in	0.406 in	1.3 in	No	No	0.89 lb

5 Pc. Curved and Long Nose Locking Plier Set

- Versatile curved jaw also features integral wire cutter
- Angled tooth pattern for a better grip
- Knurled adjusting screw turns easily by hand or with a hex key inserted into the hex key receiver on bottom of screw
- After initial grip is set, pliers can be tightened further by turning the adjusting screw with a hex key
- Compound action for powerful non-slip locking grip
- Plastisol dip on release lever for improved comfort
- Nickel-plated finish resists rust and corrosion
- Maximum jaw opening size matches ASME specifications



Cat. No.	Included Storage	Product Weight
CLP5SETN	None	4.06 lb

Cat. No.	Description	Cat. No.	Description
C5CVN	5" Curved Jaw Locking Pliers with Wire Cutter	C6NVN	6" Long Nose Locking Pliers with Wire Cutter
C7CVN	7" Curved Jaw Locking Pliers with Wire Cutter	C9NVN	9" Long Nose Locking Pliers with Wire Cutter
C10CVN	10" Curved Jaw Locking Pliers with Wire Cutter		

3 Pc. Curved Jaw Locking Pliers with Wire Cutter Set

- Versatile curved jaw also features integral wire cutter
- Angled tooth pattern for a better grip
- Knurled adjusting screw turns easily by hand or with a hex key inserted into the hex key receiver on bottom of screw
- After initial grip is set, pliers can be tightened further by turning the adjusting screw with a hex key
- Compound action for powerful non-slip locking grip
- Plastisol dip on release lever for improved comfort
- Nickel-plated finish resists rust and corrosion
- Maximum jaw opening size matches ASME specifications



Cat. No.	Included Storage	Product Weight
CLP3SETN	None	2.54 lb

Cat. No.	Description
C5CVN	5" Curved Jaw Locking Pliers with Wire Cutter
C7CVN	7" Curved Jaw Locking Pliers with Wire Cutter
C10CVN	10" Curved Jaw Locking Pliers with Wire Cutter

COMPOUND ACTION

LOCKING

2 Pc. Curved Jaw Locking Pliers with Wire Cutter Set

- Versatile curved jaw also features integral wire cutter
- Angled tooth pattern for a better grip
- Knurled adjusting screw turns easily by hand or with a hex key inserted into the hex key receiver on bottom of screw
- After initial grip is set, pliers can be tightened further by turning the adjusting screw with a hex key
- Compound action for powerful non-slip locking grip
- Plastisol dip on release lever for improved comfort
- Nickel-plated finish resists rust and corrosion
- Maximum jaw opening size matches ASME specifications



Cat. No.	Included Storage	Product Weight
CLP2SETN	None	1.980 lb

Cat. No.	Description
C7CVN	7" Curved Jaw Locking Pliers with Wire Cutter
C10CVN	10" Curved Jaw Locking Pliers with Wire Cutter

Straight Jaw Locking Pliers

- Straight jaws for maximum grip
- Angled tooth pattern for a better grip
- Knurled adjusting screw turns easily by hand or with a hex key inserted into the hex key receiver on bottom of screw
- After initial grip is set, pliers can be tightened further by turning the adjusting screw with a hex key
- Compound action for powerful non-slip locking grip
- Plastisol dip on release lever for improved comfort
- Nickel-plated finish resists rust and corrosion
- Maximum jaw opening size matches ASME specifications



Cat. No.	Overall Length	Jaw Length	Jaw Width	Jaw Thickness	Jaw Capacity	Wire Crimper	Product Weight
C7SVN	7 in	1.15 in	1.85 in	0.40 in	1.625 in	No	0.870 lb
C10SVN	10 in	1.25 in	2.15 in	0.56 in	1.875 in	No	1.245 lb

Long Nose Locking Pliers with Wire Cutter

- Versatile curved jaw also features integral wire cutter
- Angled tooth pattern for a better grip
- Knurled adjusting screw turns easily by hand or with a hex key inserted into the hex key receiver on bottom of screw
- After initial grip is set, pliers can be tightened further by turning the adjusting screw with a hex key
- Compound action for powerful non-slip locking grip
- Plastisol dip on release lever for improved comfort
- Nickel-plated finish resists rust and corrosion
- Maximum jaw opening size matches ASME specifications



Cat. No.	Overall Length	Jaw Length	Jaw Width	Jaw Thickness	Jaw Capacity	Wire Crimper	Product Weight
C6NVN	6 in	1.87 in	1.15 in	0.30 in	2.25 in	No	0.405 lb
C9NVN	9 in	2.65 in	1.6 in	0.40 in	2.875 in	No	0.875 lb

Curved Jaw Locking Pliers with Wire Cutter

- Versatile curved jaw also features integral wire cutter
- Angled tooth pattern for a better grip
- Knurled adjusting screw turns easily by hand or with a hex key inserted into the hex key receiver on bottom of screw
- After initial grip is set, pliers can be tightened further by turning the adjusting screw with a hex key
- Compound action for powerful non-slip locking grip
- Plastisol dip on release lever for improved comfort
- Nickel-plated finish resists rust and corrosion
- Maximum jaw opening size matches ASME specifications



Cat. No.	Overall Length	Jaw Length	Jaw Width	Jaw Thickness	Jaw Capacity	Wire Crimper	Product Weight
C5CVN	5 in	4 in	1.15 in	0.30 in	1.25 in	No	0.370 lb
C7CVN	7 in	5 in	1.85 in	0.40 in	1.625 in	No	0.755 lb
C10CVN	10 in	6 in	2.15 in	0.56 in	1.875 in	No	1.155 lb

LOCKING

LOCKING

Locking C-Clamps with Regular Tips

- Locking "C" clamps are faster and easier to use than standard clamps
- Regular tips work with hard surface materials
- Knurled adjusting screw turns easily by hand or with a hex key inserted into the hex key receiver on bottom of screw
- After initial grip is set, clamp can be tightened further by turning the adjusting screw with a hex key
- Compound action for powerful non-slip locking grip
- Plastisol dip on release lever for improved comfort
- Nickel-plated finish resists rust and corrosion
- Maximum jaw opening meets ASME specifications



Cat. No.	Overall Length	Jaw Length	Jaw Width	Jaw Thickness	Jaw Capacity	Wire Crimper	Packaging	Product Weight
C6CCVN	6 in	2.25 in	3.4 in	0.80 in	2 in	No	Carded	0.555 lb
C11CCVN	11 in	4.05 in	5.6 in	0.90 in	3.5 in	No	Boxed	1.765 lb
C11CCVBN	11 in	4.05 in	5.6 in	0.90 in	3.5 in	No	Bagged	1.685 lb
C18CCRN	18 in	11 in	5.6 in	0.90 in	9.25 in	No	Boxed	2.790 lb

Locking C-Clamps with Swivel Pad Tips

- Locking "C" clamps are faster and easier to use than standard clamps
- Knurled adjusting screw turns easily by hand or with a hex key inserted into the hex key receiver on bottom of screw
- After initial grip is set, clamp can be tightened further by turning the adjusting screw with a hex key
- Compound action for powerful non-slip locking grip
- Plastisol dip on release lever for improved comfort
- Nickel-plated finish resists rust and corrosion
- Maximum jaw opening meets ASME specifications



Cat. No.	Overall Length	Jaw Length	Jaw Width	Jaw Thickness	Jaw Capacity	Wire Crimper	Product Weight
C6CCSVN	6.8 in	2.25 in	3.4 in	0.80 in	2.35 in	No	0.665 lb
C11CCSVN	11 in	4.05 in	5.6 in	0.90 in	4 in	No	1.930 lb
C18CCSN	18 in	11 in	5.6 in	0.90 in	9.5 in	No	3.170 lb

Locking Sheet Metal Clamp

- Compound action for powerful non-slip locking grip
- After initial grip is set, clamp can be tightened further by turning the adjusting screw with a hex key
- Red plastisol dip on release lever for improved comfort
- Nickel-plated finish resists rust and corrosion
- Maximum jaw opening meets ASME specifications



Cat. No.	Overall Length	Jaw Length	Jaw Width	Jaw Thickness	Jaw Capacity	Wire Crimper	Product Weight
C8SMVN	8 in	1.7 in	1.95 in	3.8 in	1.63 in	No	1.130 lb
C9WN	8.8 in	2.9 in	2.75 in	2.7 in	3 in	No	1.305 lb

Quick Release Locking Chain Clamp

- 18" long chain
- Compound action for powerful non-slip locking grip
- Knurled adjusting screw turns easily by hand or with a hex key inserted into the hex key receiver on bottom of screw
- Red plastisol dip on release lever for improved comfort
- Nickel-plated finish resists rust and corrosion



Cat. No.	Overall Length	Jaw Width	Jaw Thickness	Jaw Capacity	Wire Crimper	Wire Cutter	Product Weight
C20CHN	20 in	2.45 in	0.50 in	5.7 in	No	No	1.670 lb

Electrician's Wire Stripper, Cutter and Crimper Pliers

- 5-in-1 scissor-action tool
- Wire stripper, wire cutter, bolt cutter, pliers and crimper
- Pliers nose permits wire pulling and looping of wire
- Cleanly strips and cuts 10 - 22 AWG wire
- Cuts bolts through No. 10, leaving perfect lead thread
- Crimps insulated and non-insulated solderless terminals
- Lifetime pivot bearing and red dipped handle grips



Cat. No.	Product Weight
WS19H	0.52 lb

2-in-1 Combo Linesman Pliers

- Unique design combines a lineman's plier and wire stripper in one tool
- Performs both cutting and stripping operations
- Provides the flexibility of a multi-purpose tool with the precision and performance of high quality pliers
- Wire stripper cuts and strips 20-10 AWG and 0.8 mm-2.6 mm wire
- Locking switch can be operated with one hand
- Forged alloy steel heads are strong and durable
- Induction-hardened cutting edges
- Dual material handles offer a more comfortable grip
- Wire stripper head is laser-etched with corresponding AWG and metric sizing
- Industrial black finish for corrosion protection



Cat. No.	Overall Length	Jaw Length	Wire Size	Jaw Width	Jaw Thickness	Jaw Capacity	Cutting Edge Length	Product Weight
CCP8V	8.25 in	1.375 in	20-10AWG	1.062 in	0.35 in	10 - 20 Gauge Wire	0.562 in	0.670 lb



Cutting

Aviation Snips • Shears • Tiners • Knives
Cutters • Rebar Tools • Saws

Next Generation Aviation Snips Snips made to earn the trust of a new generation.

Continuous improvement means never being satisfied. That's why these new Next Generation snips last 60% longer and require 20% less force to cut on average compared to our snips from just five years ago. And that's why Crescent Wiss is the undisputed leading brand of snips for sheet metal professionals.

**CUTS 8
MILES
OF STEEL***

**6X
PIVOT BOLT
LIFE**

**4X
SPRING
LIFE**

**UP TO
10X
CUT LIFE**



M1R Aviation Snips

- Cuts left from tight curves to straight with red handles for quick identification
- Blade serrations hold material firmly and spread cutting force uniformly across blade edge, improving cut quality and tool life
- Superior design prevents tears at end of cuts by controlling blade bypass; minimizes folding and burrs
- Cuts up to 18 gauge low carbon, rolled steel
- Spring-action handle for a faster, effortless feed
- Handles have built-in stops, providing consistent operation and blade opening
- Free float design on the pivot bolt provides longer life
- Single-handed latch operation for left or right-handed use
- Ergonomic, single material non-slip handle grips provide excellent control and easy cleaning with built-in hang hole for convenient storage
- Made in the USA



Cat. No.	Handle Color	Handed	Cutter Head / Blades	Blade Length	Cutting Capacity	Replacement Parts	Product Weight
M1R	Red	Both	Serrated	1.375 in	18 Gauge Low Carbon Steel	P406 Spring	0.40 lb

M2R Aviation Snips

- Cuts right from tight curves to straight with green handles for quick identification
- Blade serrations hold material firmly and spread cutting force uniformly across blade edge, improving cut quality and tool life
- Superior design prevents tears at end of cuts by controlling blade bypass; minimizes folding and burrs
- Cuts up to 18 gauge low carbon, rolled steel
- Spring-action handle for a faster, effortless feed
- Handles have built-in stops, providing consistent operation and blade opening
- Free float design on the pivot bolt provides longer life
- Single-handed latch operation for left or right-handed use
- Ergonomic, single material non-slip handle grips provide excellent control and easy cleaning with built-in hang hole for convenient storage
- Made in the USA



Cat. No.	Handle Color	Handed	Cutter Head / Blades	Blade Length	Cutting Capacity	Replacement Parts	Product Weight
M2R	Green	Both	Serrated	1.375 in	18 Gauge Low Carbon Steel	P407 Spring	0.40 lb

AVIATION
SNIPS

M3R Aviation Snips

- Cuts straight and slight left and right curves with yellow handles for quick identification
- Blade serrations hold material firmly and spread cutting force uniformly across blade edge, improving cut quality and tool life
- Superior design prevents tears at end of cuts by controlling blade bypass; minimizes folding and burrs
- Cuts up to 18 gauge low carbon, rolled steel
- Spring-action handle for a faster, effortless feed
- Handles have built-in stops, providing consistent operation and blade opening
- Free float design on the pivot bolt provides longer life
- Single-handed latch operation for left or right-handed use
- Ergonomic, single material non-slip handle grips provide excellent control and easy cleaning with built-in hang hole for convenient storage
- Made in the USA



Cat. No.	Handle Color	Handed	Cutter Head / Blades	Blade Length	Cutting Capacity	Replacement Parts	Product Weight
M3R	Yellow	Both	Serrated	1.5 in	18 Gauge Low Carbon Steel	P406 Spring	.90 lb

M5R Bulldog Aviation Snips

- Cuts straight lines
- For notching or trimming extra heavy stock
- Blade serrations hold material firmly and spread cutting force uniformly across blade edge, improving cut quality and tool life
- Cuts up to 16 gauge low carbon, rolled steel
- Withstands strain of cutting heavy stock and tight curves
- Spring-action handle for a faster, effortless feed
- Handle latch keeps blades closed during storage or when not in use
- Ergonomic, single material non-slip handle grips provide excellent control and easy cleaning with built-in hang hole for convenient storage
- Made in the USA



Cat. No.	Handle Color	Handed	Cutter Head / Blades	Blade Length	Cutting Capacity	Replacement Parts	Product Weight
M5R	Red	Both	Serrated	.875 in	16 Gauge Low Carbon Steel	P406 Spring	0.95 lb

M6R Offset Aviation Snips

- Cuts straight lines and left arcs
- Offset blades keep hands clear of metal while cutting
- Blade serrations hold material firmly and spread cutting force uniformly across blade edge, improving cut quality and tool life
- Cuts up to 18 gauge low carbon, rolled steel
- Spring-action handle for a faster, effortless feed
- Handle latch keeps blades closed during storage or when not in use
- Ergonomic, single material non-slip handle grips provide excellent control and easy cleaning with built-in hang hole for convenient storage
- Made in the USA



Cat. No.	Handle Color	Handed	Cutter Head / Blades	Blade Length	Cutting Capacity	Replacement Parts	Product Weight
M6R	Red	Both	Serrated	1.25 in	18 Gauge Low Carbon Steel	P406 Spring	0.40 lb

M7R Offset Aviation Snips

- Cuts straight lines and right arcs with green handles for quick identification
- Blade serrations hold material firmly and spread cutting force uniformly across blade edge, improving cut quality and tool life
- Offset blades keep hands clear of metal while cutting
- Cuts up to 18 gauge low carbon, rolled steel
- Spring-action handle for a faster, effortless feed
- Handle latch keeps blades closed during storage or when not in use
- Ergonomic, single material non-slip handle grips provide excellent control and easy cleaning with built-in hang hole for convenient storage
- Made in the USA



Cat. No.	Handle Color	Handed	Cutter Head / Blades	Blade Length	Cutting Capacity	Replacement Parts	Product Weight
M7R	Green	Both	Serrated	1.25 in	18 Gauge Low Carbon Steel	P407 Spring	0.40 lb

M80SS Offset Straight Aviation Snips

- Cuts straight lines and right and left arcs
- Blade serrations hold material firmly and spread cutting force uniformly across blade edge, improving cut quality and tool life
- Offset blades keep hands clear of metal while cutting
- Unique total system design requires 20% less force to cut
- Cuts up to 18 gauge low carbon, rolled steel
- Withstands strain of cutting heavy stock and tight curves
- Spring-action handle for a faster, effortless feed
- Handle latch keeps blades closed during storage or when not in use
- Ergonomic, single material non-slip handle grips provide excellent control and easy cleaning with built-in hang hole for convenient storage
- Made in the USA



Cat. No.	Handle Color	Handed	Cutter Head / Blades	Blade Length	Cutting Capacity	Product Weight
M80SS	Yellow	Both	Serrated	3 in	Up to 18 Gauge Steel	1.020 lb

M2X Edge Aviation Snips

- Cuts straight lines and right arcs with green handles for quick identification
- Blade serrations hold material firmly and spread cutting force uniformly across blade edge, improving cut quality and tool life
- Handle design and compound-leverage mechanism make cutting easier and reduce hand fatigue
- Integrated stops make sure the blades open all the way, every time, for maximum length of cut
- Cuts up to 18 gauge low carbon, rolled steel
- Handle latch keeps blades closed during storage or when not in use
- Dual material handle grips provide comfortable grip with built-in hang hook
- Meets or exceeds ASME specifications
- Made in the USA



Cat. No.	Handle Color	Handed	Cutter Head / Blades	Blade Length	Cutting Capacity	Product Weight
M2X	Green	Both	Serrated	1.25 in	18 Gauge Low Carbon Steel	0.95 lb

M1X Edge Aviation Snips

- Cuts straight lines and left arcs with red handles for quick identification
- Blade serrations hold material firmly and spread cutting force uniformly across blade edge, improving cut quality and tool life
- Handle design and compound-leverage mechanism make cutting easier and reduce hand fatigue
- Integrated stops make sure the blades open all the way, every time, for maximum length of cut
- Cuts up to 18 gauge low carbon, rolled steel
- Handle latch keeps blades closed during storage or when not in use
- Dual material handle grips provide comfortable grip with built-in hang hook
- Meets or exceeds ASME specifications
- Made in the USA



Cat. No.	Handle Color	Handed	Cutter Head / Blades	Blade Length	Cutting Capacity	Product Weight
M1X	Red	Both	Serrated	1.25 in	18 Gauge Low Carbon Steel	0.95 lb

M3X Edge Aviation Snips

- Cuts straight lines and right and left arcs with yellow handles for quick identification
- Blade serrations hold material firmly and spread cutting force uniformly across blade edge, improving cut quality and tool life
- Handle design and compound-leverage mechanism make cutting easier and reduce hand fatigue
- Integrated stops make sure the blades open all the way, every time, for maximum length of cut
- Cuts up to 18 gauge low carbon, rolled steel
- Handle latch keeps blades closed during storage or when not in use
- Dual material handle grips provide comfortable grip with built-in hang hook
- Meets or exceeds ASME specifications
- Made in the USA



Cat. No.	Handle Color	Handed	Cutter Head / Blades	Blade Length	Cutting Capacity	Product Weight
M3X	Yellow	Both	Serrated	1.375 in	18 Gauge Low Carbon Steel	0.95 lb

M4R Pipe & Duct Cutting Snips

- Cuts any shape ducts, seams, sheet metal stock, vinyl tiles, and plastic laminates
- Jaw action automatically adjusts blade clearance for squarer, cleaner cuts
- Spring-action handle for a faster, effortless feed
- Handle latch keeps blades closed during storage or when not in use
- Ergonomic, single material non-slip handle grips provide excellent control and easy cleaning with built-in hang hole for convenient storage



Cat. No.	Handle Color	Handed	Cutter Head / Blades	Blade Length	Cutting Capacity	Product Weight
M4RN	Gray	Both	Double Cut	.562 in	20 Gauge Low Carbon Steel	0.95 lb

MPX5 Multi-Purpose Cutter

- Blade design includes a twine cutter, wire cutter, bottle opener, and wire bending holes for added versatility
- 3" blade for cutting sheet metal, plastics, vinyl, carpet, gutters, cardboard, paper, screen, wire mesh, hose, roof shingles, wallpaper, cloth, leather, and much more
- Blade serrations hold material firmly and spread cutting force uniformly across blade edge, improving cut quality and tool life
- Compound action design delivers 1.5x the cutting power of traditional design to save you effort
- Quick-release lock for easy one-handed operation
- Nickel chrome blades resist rust and corrosion
- Ergonomic, single material non-slip handle grips provide excellent control and easy cleaning with built-in hang hole for convenient storage



Cat. No.	Handle Color	Handed	Cutter Head / Blades	Blade Length	Cutting Capacity	Product Weight
MPX5	Rawhide	Both	Serrated	3 in	20 Gauge Low Carbon Steel	0.97 lb

M300 Long Cut Aviation Snips

- Cuts straight lines and right and left arcs
- Combines long cut of tinner's snips with the strength of compound action
- Great for making long, fast cuts in sheet metal, aluminum, and much more
- Blade serrations hold material firmly and spread cutting force uniformly across blade edge, improving cut quality and tool life
- Cuts up to 20 gauge low carbon, rolled steel
- Compound action multiplies the cutting force
- Handle latch keeps blades closed during storage or when not in use
- Ergonomic, single material non-slip handle grips provide excellent control and easy cleaning with built-in hang hole for convenient storage



Cat. No.	Handle Color	Handed	Cutter Head / Blades	Blade Length	Cutting Capacity	Product Weight
M300N	Rawhide	Both	Serrated	3 in	20 Gauge Low Carbon Steel	0.98 lb

M400 Long Cut Offset Aviation Snips

- Offset blades keep hands clear of metal while cutting
- Combines long cut of tinner's snips with the strength of compound action
- Blade serrations hold material firmly and spread cutting force uniformly across blade edge, improving cut quality and tool life
- Longer blade length reduces cutting frequency for faster work
- Cuts up to 20 gauge low carbon cold rolled steel, aluminum, and plastic
- Compound action design increases force for improved performance
- Handle latch keeps blades closed during storage or when not in use
- Ergonomic, single material non-slip handle grips provide excellent control and easy cleaning with built-in hang hole for convenient storage



Cat. No.	Handle Color	Handed	Cutter Head / Blades	Blade Length	Cutting Capacity	Product Weight
M400N	Rawhide	Both	Serrated	3 in	20 Gauge Low Carbon Steel	1.05 lb

MPC3 Multipurpose Snips

- Cuts curves, straight lines, or any combination
- Used for cutting light-gauge metals, screening, floor tiles, vinyl, plastic, leather, paper, rubber, hardware cloth, shingles, tile gutters, downspouts, carpeting, and more
- Blade serrations hold material firmly and spread cutting force uniformly across blade edge, improving cut quality and tool life
- Cuts up to 20 gauge low carbon steel
- Spring-action handle for a faster, effortless feed
- Handle latch keeps blades closed during storage or when not in use
- Ergonomic, single material non-slip handle grips provide excellent control and easy cleaning with built-in hang hole for convenient storage



Cat. No.	Handle Color	Handed	Cutter Head / Blades	Blade Length	Cutting Capacity	Product Weight
MPC3SN	Rawhide	Both	Serrated	1.375 in	20 Gauge Low Carbon Steel	0.600 lb

M1RS1 Special Series Aviation Snips

- Cuts left from tight curves to straight
- Blade serrations hold material firmly and spread cutting force uniformly across blade edge, improving cut quality and tool life
- Superior design prevents tears at end of cuts by controlling blade bypass; minimizes folding and burrs
- Cuts inconel, titanium, and up to 18 gauge stainless steel
- Spring-action handle for a faster, effortless feed
- Handles have built-in stops, providing consistent operation and blade opening
- Free float design on the pivot bolt provides longer life
- Single-handed latch operation for left or right-handed use
- Ergonomic, single material non-slip handle grips provide excellent control and easy cleaning with built-in hang hole for convenient storage
- Made in the USA



Cat. No.	Handle Color	Handed	Cutter Head / Blades	Blade Length	Cutting Capacity	Product Weight
M1RS1	Blue	Both	Serrated	1.375 in	18 Gauge Stainless Steel	0.90 lb

M2RS1 Special Series Aviation Snips

- Cuts right from tight curves to straight
- Blade serrations hold material firmly and spread cutting force uniformly across blade edge, improving cut quality and tool life
- Superior design prevents tears at end of cuts by controlling blade bypass; minimizes folding and burrs
- Cuts inconel, titanium, and up to 18 gauge stainless steel
- Spring-action handle for a faster, effortless feed
- Handles have built-in stops, providing consistent operation and blade opening
- Free float design on the pivot bolt provides longer life
- Single-handed latch operation for left or right-handed use
- Ergonomic, single material non-slip handle grips provide excellent control and easy cleaning with built-in hang hole for convenient storage
- Made in the USA



Cat. No.	Handle Color	Handed	Cutter Head / Blades	Blade Length	Cutting Capacity	Product Weight
M2RS1	Blue	Both	Serrated	1.375 in	18 Gauge Stainless Steel	0.90 lb

AVIATION
SNIPS

Not just scissors and shears... Precision cutting tools made for pros.

The new and improved line of Crescent Wiss shears and scissors offers the performance, strength, and durability professional users need. Every scissor and shear has been upgraded with new features that deliver more comfort, superior results, and longer life. High-performance models feature titanium-coated blades for smooth, powerful cuts and several have a full metal core for maximum strength and durability.

2X STRONGER

FULL METAL CORE
Extends through handle for durability and strength

Ergonomic Design
Optimizes handle contact points to maximize comfort and control

Heavy Duty Titanium Coated Blades
For powerful cutting and long life

Control Channel
Fits index finger for improved control and more power

Serrated Bottom Blade
Grips material for greater control

HANDLE XL RINGS

SERRATED 10X POWER EDGE

USE FOR
LANDSCAPING
FLOORING
ROOFING
SIDING
AND MORE

CW10TM

Titanium Coated Tradesman Utility Shears

- Heavy-duty blades feature premium grade stainless steel and are precision engineered for knife-like cutting edges
- Compact 7.5 inch design allows for easy storage and provides excellent portability
- Titanium coated blades provide corrosion resistance and are 3X harder than steel for durability and tool life
- Quick release ergonomic latch provides consistent easy operation and secures the tool in the closed and locked position for safe storage
- TPR comfort grip handles with soft-grip texture provide best-in-class comfort and control
- Touch point ergonomics optimize hand and finger contact points in handles to maximize fit, control, and user ergonomics



Cat. No.	Handed	Cutter Head / Blades	Blade Length	Product Weight
CW7T	Both	Bottom Serrated	2 in	0.400 lb

Stainless Steel All Purpose Tradesman Shears

- Precision ground blades feature premium grade stainless steel and are precision engineered for knife-like cutting edges
- Easy adjust pivot bolt allows quick and easy adjustment to fine tune cutting blade tension for optimal cutting performance
- Ambidextrous handle design features symmetrical handle ring contouring for comfortable right or left hand usage
- Stainless steel blades provide corrosion resistance and are harder than steel for durability and tool life



Cat. No.	Handed	Cutter Head / Blades	Blade Length	Product Weight
CW812S	Both	Smooth	3.25 in	0.300 lb

Heavy-Duty Titanium Coated Single Ring Tradesman Shears

- Heavy-duty blades feature titanium coated premium grade stainless steel and are precision engineered for knife-like cutting edges
- Spring-loaded design automatically opens when latch is disengaged for reduced hand fatigue
- Touch point ergonomics optimize hand and finger contact points in handles to maximize fit, control, and user ergonomics
- Full metal core extends through the handle for maximum strength and increased durability
- Serrated bottom blade grips material as it is being cut for increased cutting control and cleaner cuts
- Control channel accommodates index finger for increased control and cutting stability
- Quick release ergonomic latch provides consistent easy operation and secures the tool in the closed and locked position for safe storage



Cat. No.	Handed	Cutter Head / Blades	Blade Length	Product Weight
CW11TM	Both	Bottom Serrated	4 in	0.800 lb

Heavy-Duty Titanium Coated Tradesman Shears

- Heavy-duty blades feature premium grade stainless steel and are precision engineered for knife-like cutting edges
- Serrated bottom blade grips material as it is being cut for increased cutting control and cleaner cuts
- Titanium coated blades provide corrosion resistance and are 3X harder than steel for durability and tool life
- Control channel accommodates index finger for increased control and cutting stability
- Full metal core extends through the handle for maximum strength and increased durability
- Touch point ergonomics optimize hand and finger contact points in handles to maximize fit, control, and user ergonomics



Cat. No.	Handed	Cutter Head / Blades	Blade Length	Product Weight
CW10TM	Right	Bottom Serrated	4 in	0.700 lb

Titanium Coated Offset Tradesman Shears

- Precision cut blades feature titanium coated premium grade steel and are precision engineered for knife-like cutting edges
- Offset handle design keeps hands above material for safety and easy table top cuts
- Touch point ergonomics optimize hand and finger contact points in handles to maximize fit, control, and user ergonomics
- Titanium coated blades provide corrosion resistance and are 3X harder than steel for durability and tool life
- Control channel accommodates index finger for increased control and cutting stability
- TPR comfort grip handles are strategically textured using soft-grip TPR to provide best-in-class user comfort and control



Cat. No.	Handed	Cutter Head / Blades	Blade Length	Product Weight
CW10T	Right	Smooth	3.75 in	0.600 lb
CW10TL	Left	Smooth	3.75 in	0.600 lb

Electrician's Data Shears

- Integrated wire strippers in scissor blade for quick and easy stripping of 19 and 23 AWG wires
- Serrated outside edges of blades for reaming knockouts and conduit
- Grip-Zone area for tightening wire nuts and crimping low voltage connections
- Precision ground blades feature durable serrations on the bottom blade that grip material for better control and cleaner cuts
- Integrated cable cutter provides added power and grip needed to make clean shear cuts through electrical cable
- Touch point ergonomics optimize hand and finger contact points in handles to maximize fit, control, and user ergonomics



Cat. No.	Handed	Cutter Head / Blades	Blade Length	Product Weight
CW5T	Both	Bottom Serrated	1.75 in	0.300 lb

Electronics and Filament Scissors

- Hot drop-forged solid steel
- Coil spring handle opens blades after each cut
- Straight blades
- Polished blades with black handles



Cat. No.	Handed	Blade Length	Overall Length	Product Weight
605N	Both	.75 in	5 in	0.22 lb

Electrician's Scissors

- Double stripping notch for 19 gauge (0.035) and 23 gauge (0.022) wire
- Hot drop-forged solid steel
- Serrated along entire bottom blade
- Scraper and file on back edge of blade
- Fully nickel-plated
- Packaged in vinyl pouch



Cat. No.	Handed	Cutter Head / Blades	Blade Length	Overall Length	Packaging	Product Weight
175E	Both	No Serrations	1.75 in	5.25 in	Boxed	0.20 lb
175E5V	Both	Bottom Serrated	1.75 in	5.25 in	Carded	0.20 lb
175E5	Both	Bottom Serrated	1.75 in	5.25 in	Boxed	0.20 lb

2 Pc. Home, Craft, and Sew Scissor Set

- Strong, stainless steel blades for corrosion resistance
- Sharp points cut cleanly through the tip
- Long-lasting precision ground straight edges can be sharpened
- Adjustable pivot screw for best feel
- Soft touch handles for added comfort
- Lightweight



Cat. No.	Product Weight
WHCS2	0.44 lb

Cat. No.	Description
-	5" Sewing Scissors with Soft Touch Handles
-	8-1/4" Craft Scissors with Soft Touch Handles

Shop Shears

- Strong, high quality stainless steel blades for corrosion resistance
- Serrated lower blade for better grip on materials being cut
- Cutting notch on lower blade for rope and twine
- Adjustable pivot to change cutting tension for best feel
- Hard plastic handles clean easily
- Safety point



Cat. No.	Handed	Blade Length	Overall Length	Product Weight
W912	Both	4.25 in	10 in	0.33 lb

Take-Apart Utility Scissors

- Strong, high quality stainless steel blades for corrosion resistance
- Take-apart blades for easy cleaning
- Hard handles are dishwasher safe
- Lightweight



Cat. No.	Handed	Blade Length	Overall Length	Product Weight
W8TA	Both	4 in	8 in	0.25 lb

Easy Snip Utility Shears

- Strong, stainless steel blades for corrosion resistance
- Textured and molded handles for a secure, comfortable grip
- Spring assist action minimizes hand fatigue
- Wire cutting notch in the lower blade
- Thumb latch secures blades closed during storage
- Ideal for use in the shop, garden, and home



Cat. No.	Handed	Cutter Head / Blades	Blade Length	Overall Length	Product Weight
WEZSNIP	Both	Stainless Steel Blades	4 in	8.5 in	0.18 lb

Heavy Duty Industrial Shears

- Commonly used in cutting fabrics, upholstery, and composite materials
- Precision ground blades provide sharper cutting edges and a longer blade life
- Hot drop-forged nickel-plated blades are strong and durable
- Handle rings designed to comfortably fit users' hands
- Configure the SET-EASY® pivot adjustment to match your preference



Cat. No.	Handed	Handle Style	Blade Length	Overall Length	Product Weight
W20	Both	Bent	4.75 in	10.375 in	0.88 lb
W20LH	Left	Bent	5 in	10.375 in	0.88 lb
W22N	Both	Bent	6 in	12.5 in	1.20 lb

Heavy Duty Cushion Grip Industrial Shears

- Commonly used in cutting fabrics, upholstery, and composite materials
- Precision ground blades provide sharper cutting edges and a longer blade life
- Hot drop-forged nickel-plated blades are strong and durable
- Red dipped handle rings designed to comfortably fit users' hands
- Configure the SET-EASY® pivot adjustment to match your preference



Cat. No.	Handed	Handle Style	Blade Length	Overall Length	Product Weight
W20P	Both	Bent	5 in	10.375 in	0.88 lb
W22P	Both	Bent	6 in	12.5 in	1.20 lb

Industrial Shears

- Perfect for a professional dressmaker or industrial use
- Primarily used for working with fabric and thread
- Precision ground blades for sharper cutting edges and longer blade life
- Hot drop-forged nickel-plated blades are strong and durable
- Handles made of coated high carbon steel
- SET-EASY® pivot easily and securely adjusts to user preference



Cat. No.	Handed	Blade Length	Overall Length	Packaging	Product Weight
426N	Both	2.375 in	6.25 in	Carded	0.22 lb
427N	Both	2.75 in	7 in	Carded	0.30 lb
27N	Both	2.75 in	7 in	Boxed	0.30 lb
428N	Both	3.375 in	8 in	Carded	0.40 lb
28N	Both	3.375 in	8 in	Boxed	0.45 lb
29N	Both	4 in	9 in	Boxed	0.45 lb

High Leverage Industrial Shears

- Precision ground blades for sharper cutting edges and longer blade life
- Hot drop-forged nickel-plated blades are strong and durable
- Blade tips rounded for extra protection
- Handle rings designed to comfortably fit users' hands
- Red cushion grip handles provide maximum comfort
- SET-EASY® pivot easily and securely adjusts to user preference



Cat. No.	Handed	Blade Length	Overall Length	Product Weight
W1225HLSP	Both	5 in	10.375 in	0.88 lb

Upholstery, Carpet, Drapery, and Fabric Shears

- Ideal for cutting upholstery, carpet, and drapery
- Precision ground blades for sharper cutting edges and longer blade life
- Hot drop-forged nickel-plated blades are strong and durable
- Thick heavy-duty blades for cutting multiple layers and tough materials
- Handle rings designed to comfortably fit users' hands
- SET-EASY® pivot easily and securely adjusts to user preference



Cat. No.	Handed	Blade Length	Overall Length	Product Weight
W20W	Both	5 in	10.375 in	0.88 lb
W22W	Both	6 in	12.5 in	1.20 lb

Upholstery, Carpet, and Fabric Shears

- Ideal for cutting carpet, synthetic fibers and composite materials
- Precision ground blades for sharper cutting edges and longer blade life
- Hot drop-forged nickel-plated blades are strong and durable
- Precision ground blades for sharper cutting edges and longer blade life
- One blade ground to knife edge for faster, cleaner cutting
- Handle rings designed to comfortably fit users' hands
- SET-EASY® pivot easily and securely adjusts to user preference



Cat. No.	Handed	Blade Length	Overall Length	Product Weight
W1225	Both	5 in	10.375 in	0.88 lb
W1226	Both	6 in	12.5 in	1.20 lb

Rug Shears for Hooked and Candlewick Rugs

- Hot drop-forged solid steel blades
- Nickel-plated blades with sharp points
- Black baked enamel handle



Cat. No.	Handed	Blade Length	Overall Length	Product Weight
RS1N	Both	2.875 in	8 in	0.35 lb

Double Rounded Shears

- Precision ground blades for sharper cutting edges and longer blade life
- Hot drop-forged nickel-plated blades are strong and durable
- Blade tips rounded for extra protection
- Handle rings designed to comfortably fit users' hands



Cat. No.	Handed	Blade Length	Overall Length	Product Weight
W20SP	Both	5 in	10.375 in	0.88 lb

Industrial Straight Trimmers

- Ideal for cutting various fabrics and upholstery
- Precision ground blades for sharper cutting edges and longer blade life
- Hot drop-forged nickel-plated blades and handles are strong and durable
- Handle rings designed to comfortably fit users' hands
- SET-EASY® pivot easily and securely adjusts to user preference



Cat. No.	Handed	Blade Length	Overall Length	Packaging	Product Weight
37N	Both	2.875 in	7 in	Boxed	0.20 lb
438N	Both	3.625 in	8.25 in	Carded	0.40 lb
T38N	Both	3.625 in	8.25 in	Boxed	0.35 lb
W30	Both	5 in	10.375 in	Carded	0.88 lb

Belt and Leather Cutting Shears

- Ideal for cutting leather and welt cord
- Hot drop-forged nickel-plated blades are strong and durable
- One blade is serrated; the other blade is edged
- Handle rings designed to comfortably fit users' hands
- SET-EASY® pivot easily and securely adjusts to user preference



Cat. No.	Handed	Blade Length	Overall Length	Product Weight
W8BLT	Both	3.375 in	8.5 in	0.75 lb

Pinking Shears

- Cuts a wide range of fabrics and leaves a ruffled edge that will not fray
- Pinks and cuts in one operation, saving time and labor
- Sawtooth blade design reduces the time spent finishing edges on fabrics
- Hot drop-forged nickel-plated blades are strong and durable



Cat. No.	Handed	Blade Length	Overall Length	Product Weight
CB8	Both	4.5 in	8.25 in	0.55 lb

Pocket Scissors

- Blades are a flat pattern with double blunt points
- Hot drop-forged nickel-plated blades and handles are strong and durable
- Ring handle



Cat. No.	Handed	Blade Length	Overall Length	Product Weight
166	Both	2.75 in	6.25 in	0.20 lb

Sewing and Embroidery Scissors

- Specially designed for intricate cutting, embroidery, and fine needlework
- Hot drop-forged nickel-plated blades and handles are strong and durable
- Double sharp points
- Flat pattern
- Ring handle
- Packaged in vinyl pouch



Cat. No.	Handed	Blade Length	Overall Length	Product Weight
T764	Both	1.25 in	4.125 in	0.10 lb
765	Both	2 in	5.125 in	0.10 lb

Industrial Thread Nippers

- Hot drop-forged nickel-plated blades are strong and durable
- Self-opening spring-action assures fast, effortless cutting



Cat. No.	Point Style	Handed	Blade Length	Overall Length	Product Weight
TC5	Blunt	Both	1 in	4.625 in	0.13 lb
TC1	Sharp	Both	1.125 in	4.75 in	0.13 lb

Quick-Clip® Speed Cutters

- Rust-resistant stainless steel replaceable blades
- Positive spring-action opens the blades for fast cutting
- Heavy-duty contoured design
- Durable plastic handle made of industrial PVC



Cat. No.	Point Style	Handed	Blade Length	Overall Length	Replacement Blade No.	Product Weight
1571BN	Blunt	Both	1 in	4.75 in	T9329	0.090 lb
1570BN	Sharp	Both	1 in	4.75 in	T9328	0.090 lb

Industrial Shears

- Used extensively in the poultry industry
- Precision ground blades for sharper cutting edges and longer blade life
- Hot drop-forged nickel-plated blades and handles are strong and durable
- Handle rings designed to comfortably fit users' hands
- Enlarged lower ring for increased comfort
- SET-EASY® pivot easily and securely adjusts to user preference



Cat. No.	Handed	Blade Length	Overall Length	Product Weight
1DSN	Both	2.75 in	8.125 in	0.45 lb

Poultry Processing Shears

- Used extensively in poultry processing
- Special ball point for poultry processing
- Hot drop-forged nickel-plated blades and handles are strong and durable
- Adjustable pivot nut



Cat. No.	Handed	Blade Length	Overall Length	Product Weight
41DBN	Both	2.875 in	8.625 in	0.50 lb

High Leverage Shears

- Cuts wire used in floral designs and other similar crafts
- Hot drop-forged commercial nickel-plated solid steel
- Serrated nickel-plated blades grip material being cut
- Black, curved handle designed for comfort and reduced fatigue



Cat. No.	Handed	Blade Length	Overall Length	Product Weight
2DAN	Both	2 in	7.75 in	0.50 lb

Kitchen Shears

- Ideal for many miscellaneous jobs in and around the home
- Cuts a variety of materials including twine, rope, cardboard, light metal
- Hot drop-forged stainless steel blades are strong and durable
- One blade is serrated
- Black baked enamel handle



Cat. No.	Handed	Blade Length	Overall Length	Product Weight
KSRN	Both	2.625 in	8 in	0.28 lb

Industrial Trimming, Grape Thinning & Orchid Snips

- Hot drop-forged solid steel blades are strong and durable
- Straight, polished blades with adjustable nut
- Coil spring handle opens blades after each cut
- Black baked enamel handle with closing latch



Cat. No.	Handed	Blade Length	Overall Length	Product Weight
C4ASN	Both	2.25 in	8 in	0.44 lb

Light Metal-Cutting Snips

- Used in electronic and appliance light metal cutting
- Comes with polished straight blades



Cat. No.	Handed	Blade Length	Overall Length	Product Weight
J7SN	Both	1 in	7 in	0.25 lb

Straight Pattern Tinner Snips

- Hot drop-forged steel blades provide market-leading strength, durability, and excellent cutting performance over tool life
- Precision-ground cutting edges provide superior cutting quality and reduced cutting effort through optimized blade geometry
- Through broached bolt allows for market leading cycle cut life – yielding greater than 3X the ASME specification
- High durometer grips for superior comfort, control, and overall product durability
- Torque control handle rings provide superior comfort, fit, and are sized to accommodate hands with or without gloves
- Touch point ergonomics optimize hand & finger contact points in handles to maximize fit, control, and user ergonomics



Cat. No.	Cutter Head / Blades	Overall Length	Blade Length	Cutting Capacity	Product Weight
WDF7S	Smooth	7.2 in	1.62 in	Light Steel and Vinyl	1.440 lb
WDF10S	Smooth	10.35 in	2 in	Light Steel and Vinyl	1.440 lb
WDF12S	Smooth	12.28 in	2.75 in	Light Steel and Vinyl	1.700 lb

Offset Pattern Tinner Snips

- Hot drop-forged steel blades provide market-leading strength, durability, and excellent cutting performance over tool life
- Precision-ground cutting edges provide superior cutting quality and reduced cutting effort through optimized blade geometry
- Through broached bolt allows for market leading cycle cut life — yielding greater than 3X the ASME specification
- High durometer grips for superior comfort, control, and overall product durability
- Torque control handle rings provide superior comfort, fit, and are sized to accommodate hands with or without gloves
- Touch point ergonomics optimize hand & finger contact points in handles to maximize fit, control, and user ergonomics



Cat. No.	Cutter Head / Blades	Overall Length	Blade Length	Cutting Capacity	Product Weight
WDF100	Smooth	11.25 in	2 in	Light Steel and Vinyl	1.455 lb

Bulldog Pattern Tinner Snips

- Hot drop-forged steel blades provide market-leading strength, durability, and excellent cutting performance over tool life
- Precision-ground cutting edges provide superior cutting quality and reduced cutting effort through optimized blade geometry
- Through broached bolt allows for market leading cycle cut life — yielding greater than 3X the ASME specification
- High durometer grips for superior comfort, control, and overall product durability
- Torque control handle rings provide superior comfort, fit, and are sized to accommodate hands with or without gloves
- Touch point ergonomics optimize hand & finger contact points in handles to maximize fit, control, and user ergonomics



Cat. No.	Cutter Head / Blades	Overall Length	Blade Length	Cutting Capacity	Product Weight
WDF16BD	Smooth	16.57 in	2.25 in	Light Steel and Vinyl	3.500 lb

Duckbill Pattern Tinner Snips

- Hot drop-forged steel blades provide market-leading strength, durability, and excellent cutting performance over tool life
- Precision-ground cutting edges provide superior cutting quality and reduced cutting effort through optimized blade geometry
- Through broached bolt allows for market leading cycle cut life — yielding greater than 3X the ASME specification
- High durometer grips for superior comfort, control, and overall product durability
- Torque control handle rings provide superior comfort, fit, and are sized to accommodate hands with or without gloves
- Touch point ergonomics optimize hand & finger contact points in handles to maximize fit, control, and user ergonomics



Cat. No.	Cutter Head / Blades	Overall Length	Blade Length	Cutting Capacity	Product Weight
WDF10D	Smooth	10.35 in	2 in	Light Steel and Vinyl	1.125 lb
WDF12D	Smooth	12.28 in	2.75 in	Light Steel and Vinyl	1.715 lb

Lightweight Aluminum Tinner Snips

- Precision-ground cutting edges provide superior cutting quality and reduced cutting effort through optimized blade geometry
- Torque control handle rings provide superior comfort, fit, and are sized to accommodate hands with or without gloves
- Lightweight design heavy-duty die cast aluminum construction is durable and reduces user fatigue
- Control channel accommodates index finger for increased control and cutting stability
- Touch point ergonomics optimize hand & finger contact points in handles to maximize fit, control, and user ergonomics
- Easy adjust pivot bolt allows quick and easy adjustment to fine tune cutting blade tension for optimal cutting performance



Cat. No.	Cutter Head / Blades	Overall Length	Blade Length	Cutting Capacity	Product Weight
WAL13S	Smooth	12.8 in	3 in	Light Steel and Vinyl	1.395 lb

The Hardest-Working Every Day Carry

When you have a Crescent pocket knife, you've got the hardest-working Every Day Carry on the jobsite. Designed for professional tradespeople, each one is a no-nonsense tool that can be counted on to perform reliably every time it's needed. And with a selection of blade types and blade and handle materials, there's a Crescent pocket knife made to suit every personal style and requirement.



Drop Point Aluminum Handle Pocket Knife

- Heavy-duty D2 steel blade provides excellent strength, edge retention, and overall product durability
- Smooth action heavy-duty ball bearing system provides quick and easy blade deployment for the life of the tool
- Ergonomic handle optimizes hand and finger contact points to maximize fit, control, and user ergonomics
- Drop point blade design provides tip strength and overall blade durability for a variety of cutting applications
- Easy action flipper tab for easy blade deployment
- Liner lock mechanism provides secure locking of blade in open position and easy closing action
- Heavy-duty anodized aluminum handle provides excellent strength to weight ratio for optimal performance



Cat. No.	Handed	Cutter Head / Blades	Handle Material	Blade Length	Overall Length	Product Weight
CPK325A	Both	Drop Point	Aluminum	3.25 in	8 in	0.345 lb

Harpoon Blade Aluminum Handle Pocket Knife

- Heavy-duty D2 steel blade provides excellent strength, edge retention, and overall product durability
- Smooth action heavy-duty ball bearing system provides quick and easy blade deployment for the life of the tool
- Ergonomic handle optimizes hand and finger contact points to maximize fit, control, and user ergonomics
- Harpoon blade design provides overall blade durability and extra leverage for a variety of cutting applications
- Easy action flipper tab for easy blade deployment
- Liner lock mechanism provides secure locking of blade in open position and easy closing action
- Heavy-duty anodized aluminum handle provides excellent strength to weight ratio for optimal performance



Cat. No.	Handed	Cutter Head / Blades	Handle Material	Blade Length	Product Weight
CPK350A	Both	Harpoon	Aluminum	3.5 in	0.451 lb

Drop Point Composite Handle Pocket Knife

- 5Cr15MoV steel blade features premium grade stainless steel and is precision-ground for excellent cutting performance
- Smooth action heavy-duty ball bearing system provides quick and easy blade deployment for the life of the tool
- Ergonomic handle optimizes hand and finger contact points to maximize fit, control, and user ergonomics
- Drop point blade design provides tip strength and overall blade durability for a variety of cutting applications
- Easy action flipper tab for easy blade deployment
- Liner lock mechanism provides secure locking of blade in open position and easy closing action
- Composite handle is ergonomically designed to optimize hand and finger contact points for enhanced fit and superior control



Cat. No.	Handed	Cutter Head / Blades	Handle Material	Blade Length	Overall Length	Product Weight
CPK325C	Both	Drop Point	Glass Filled Nylon	3.25 in	8 in	0.345 lb

Harpoon Blade Composite Handle Pocket Knife

- 5Cr15MoV steel blade features premium grade stainless steel and is precision-ground for excellent cutting performance
- Smooth action heavy-duty ball bearing system provides quick and easy blade deployment for the life of the tool
- Ergonomic handle optimizes hand and finger contact points to maximize fit, control, and user ergonomics
- Harpoon blade design provides overall blade durability and extra leverage for a variety of cutting applications
- Easy action flipper tab for easy blade deployment
- Liner lock mechanism provides secure locking of blade in open position and easy closing action
- Composite handle is ergonomically designed to optimize hand and finger contact points for enhanced fit and superior control



Cat. No.	Handed	Cutter Head / Blades	Handle Material	Blade Length	Overall Length	Product Weight
CPK350C	Both	Harpoon	Glass Filled Nylon	3.5 in	8.5 in	0.451 lb

Quick-Change Folding Blade Utility Knife

- Compact, ergonomic design
- Blade locks in the open position for secure cutting
- Blade safely folds into handle for compact size and easy storage
- Blades coated in black oxide for improved corrosion resistance
- Features quick-change latch for quick blade replacements
- Compatible with all standard utility knife blades
- Blade storage compartment in the handle holds additional blades
- Includes belt/pocket clip
- Includes bonus 10-pack of blades
- WARNING: Sharp blade included; use care when handling



Cat. No.	Handle Material	Blades	Blade Length	Blade Material	Closed Length	Open Length	Product Weight
WKF2	Dual Material	11	1.0625 in	Steel	4.55 in	7.4 in	0.60

Auto-Retracting Utility Knife

- Blade retracts automatically the moment it loses contact with the material being cut – even if the user is still holding the blade slider forward in the ‘open’ position
- Helps reduce workplace injuries, lowering lost time and increasing productivity
- Quick and easy blade change
- Compatible with all standard utility knife blades
- Blade storage compartment in the handle holds additional blades
- Includes three black-coated blades
- WARNING: Sharp blade included; use care when handling



Cat. No.	Handle Material	Blades	Blade Material	Overall Length	Product Weight
WKR2	Dual Material	3	Steel	7 in	0.52

Retractable Utility Knife

- Popular all-purpose retractable knife
- Easy-run slide uses all standard replacement blades
- Metal case painted red for easy visibility
- Made in the USA
- WARNING: Sharp blade included; use care when handling



Cat. No.	Handle Material	Number of Blades	Blade Material	Overall Length	Product Weight
WK8V	Steel	3	Steel	8 in	0.38 lb

Quick-Change Comfort Grip Utility Knife

- Retractable utility knife with 11 positions
- Comfort grip for ease of use and slip protection
- Safety string cutter with recessed blade
- Quick change blade release and reload
- Magazine blade storage holds 3 blades
- WARNING: Sharp blade included; use care when handling



Cat. No.	Handle Material	Blades	Blade Material	Overall Length	Product Weight
WK500V	Dual Material	4	Steel	7 in	0.35 lb

Fixed Blade Knife

- Heavy-duty, fixed blade knife
- Uses standard utility knife blades
- Metal case painted red for easy visibility
- Includes three blades
- Made in the USA
- WARNING: Sharp blade included; use care when handling



Cat. No.	Handle Material	Blades	Blade Material	Overall Length	Product Weight
WK9V	Steel	3	Steel	8.25 in	0.36 lb

Utility Blades

- High quality steel utility knife blades
- Replacement blades fit most utility knives
- Heavy-duty blades with sharp points
- Blade packaging is designed to fit in most vending machines for convenient access and purchasing



Cat. No.	Point Style	Blades	Used On	Product Weight
RWK14D	Sharp	100	Standard Utility Knives	0.97 lb
RWK14V	Sharp	5	Standard Utility Knives	0.02 lb
RWK14VR	Rounded Safety	5	Standard Utility Knives	0.090 lb
RWK16V	Hook	5	Standard Utility Knives	0.06 lb

PowerPivot™ Industrial Grade Center Cut Bolt Cutters

- PowerPivot™ technology for superior cutting power
- Precision engineered induction hardened center cut blades
- Double compound cutting action
- Cuts materials up to Brinell 455 or Rockwell C48 hardness
- Heat treated for wear resistance and long cutting life
- Tubular steel handles for ultimate strength and cutting support
- Screw-type adjustment realigns edges
- NEVER use any H.K. Porter cutters on energized circuits, wire, or cable!



Cat. No.	Overall Length	Soft/Medium/Hard Materials (Up to Brinell 300, Rockwell C31)	Hard Materials (Up to Brinell 455, Rockwell C48)	Max. Capacity	Reinforcing Rod and Bar	Replacement Cutterhead/ Jaws Cat. No.	Product Weight
1490MCP	14 in	5/16 in, 8 mm	7/32 in, 5 mm	1/4 in, 6 mm	5/16 in, 8 mm	0413C	3.200 lb
0090MCP	18.55 in	3/8 in, 10 mm	9/32 in, 7 mm	1/4 in, 6 mm	3/8 in, 10 mm	0013C	5.000 lb
0190MCP	26.7 in	7/16 in, 11 mm	5/16 in, 8 mm	5/16 in, 8 mm	7/16 in, 11 mm	0113C	0.194 lb
0290MCP	30.95 in	1/2 in, 13 mm	3/8 in, 10 mm	7/16 in, 11 mm	1/2 in, 13 mm	0213C	10.435 lb
0390MCP	37.12 in	9/16 in, 14 mm	7/16 in, 11 mm	1/2 in, 13 mm	9/16 in, 14 mm	0313C	16.350 lb

Industrial Grade, Center Cut Cutters

- Drop-forged precision ground, alloy tool steel jaws with center-cut blades
- Cut materials up to Brinell 455 or Rockwell C48 hardness
- Toggle joints turn 50 lbs of hand pressure into 4000 lbs of cutting pressure
- Screw-type adjustment realigns edges
- Lockplate keeps jaws from loosening
- Steel handles with rubber grips
- Designed, engineered, and manufactured in the USA
- Made in the USA
- NEVER use any H.K. Porter cutters on electrified circuits, wire, or cable!



Cat. No.	Overall Length	Soft/Medium/Hard Materials (Up to Brinell 300, Rockwell C31)	Hard Materials (Up to Brinell 455, Rockwell C48)	Max. Capacity	Reinforcing Rod and Bar	Replacement Cutterhead/ Jaws Cat. No.	Product Weight
1490MC	14 in	5/16 in, 8 mm	3/16 in, 5 mm	3/16 in, 5 mm	-	1413C	3.20 lb
0090MC	18 in	3/8 in, 10 mm	1/4 in, 6 mm	1/4 in, 6 mm	3/8 in, 10 mm	0013C	3.70 lb
0190MC	24 in	7/16 in, 11 mm	5/16 in, 8 mm	5/16 in, 8 mm	5/16 in, 8 mm	0113C	6.45 lb
0290MC	30 in	1/2 in, 13 mm	3/8 in, 10 mm	3/8 in, 10 mm	#3 Bar 3/8 in, 10 mm	0213C	10.15 lb
0390MC	36 in	9/16 in, 14 mm	7/16 in, 11 mm	7/16 in, 11 mm	7/16 in, 11 mm	0313C	16.05 lb
0590MC	42 in	11/16 in, 18 mm	1/2 in, 13 mm	1/2 in, 13 mm	1/2 in, 13 mm	0513C	20.267

Industrial Grade, Clipper Cut Cutters

- All-purpose jaws with clipper-cut blades for close or flush cutting
- Maximum hardness of material to be cut: Brinell 300/Rockwell C31
- Toggle joints turn 50 lbs of hand pressure into 4000 lbs of cutting pressure
- Screw-type adjustment realigns edges
- Lockplate keeps jaws from loosening
- Not for cutting hard materials
- Made in the USA
- NEVER use any H.K. Porter cutters on electrified circuits, wire, or cable!



Cat. No.	Overall Length	Soft /Medium Hard Materials (Up to Brinell 300, Rockwell C31)	Max. Capacity	Replacement Cutterhead/ Jaws Cat. No.	Product Weight
0090MNE	18 in	5/16 in, 8 mm	5/16 in, 8 mm	0013NE	3.75 lb
0190MNE	24 in	7/16 in, 11 mm	7/16 in, 11 mm	0113NE	5.25 lb

General Purpose, Center Cut Cutters

- All-purpose jaws with center-cut blades
- Strong, lightweight fiberglass handles
- Toggle joints turn 50 lbs of hand pressure into 4000 lbs of cutting pressure
- Screw-type adjustment realigns edges
- Cuts soft, medium, and hard metals
- Cuts materials up to Brinell 455 or Rockwell C48 hardness
- Lockplate keeps jaws from loosening
- Designed, engineered, and manufactured in the USA
- Made in the USA
- NEVER use any H.K. Porter cutters on electrified circuits, wire, or cable!



Cat. No.	Overall Length	Soft/Medium Hard Materials (Up to Brinell 300, Rockwell C31)	Hard Materials (Up to Brinell 455, Rockwell C48)	Max. Capacity	Reinforcing Rod and Bar	Replacement Cutterhead/ Jaws Cat. No.	Product Weight
0090FC	18.25 in	3/8 in, 10 mm	1/4 in, 6 mm	1/4 in, 6 mm	3/8 in, 10 mm	0013C	3.60 lb
0190FC	24.5 in	7/16 in, 11 mm	5/16 in, 8 mm	5/16 in, 8 mm	3/8 in, 10 mm	0113C	5.70 lb
0290FC	30.5 in	1/2 in, 13 mm	3/8 in, 10 mm	3/8 in, 10 mm	1/2 in, 13 mm	0213C	7.50 lb
0390FC	36.5 in	9/16 in, 14 mm	7/16 in, 11 mm	7/16 in, 11 mm	1/2 in, 13 mm	0313C	13.40 lb

Heavy Duty Cutters - Steel Handles

- Recommended for the most demanding hand cutting applications
- Heavy-duty straps support the jaws
- Maximum hardness of material to be cut: Brinell 455/Rockwell C48
- Toggle joints turn 50 lbs of hand pressure into 4000 lbs of cutting pressure
- Screw-type adjustment realigns edges
- Lockplate keeps jaws from loosening
- Tubular steel handles
- Designed, engineered, and manufactured in the USA
- Made in the USA
- NEVER use any H.K. Porter cutters on electrified circuits, wire, or cable!



Cat. No.	Overall Length	Soft/Medium Hard Materials (Up to Brinell 300, Rockwell C31)	Hard Materials (Up to Brinell 455, Rockwell C48)	Max. Capacity	Reinforcing Rod and Bar	Replacement Cutterhead/ Jaws Cat. No.	Product Weight
0190MCX	24 in	7/16 in, 11 mm	5/16 in, 8 mm	5/16 in, 8 mm	5/16 in, 8 mm	0113CX	6.40 lb
0290MCX	30 in	1/2 in, 13 mm	3/8 in, 10 mm	3/8 in, 10 mm	#3 Bar 3/8 in, 10 mm	0213CX	9.25 lb
0390MCX	36 in	9/16 in, 14 mm	7/16 in, 11 mm	7/16 in, 11 mm	1/2 in, 13 mm	0313CX	17.50 lb

Heavy Duty Cutters - Fiberglass Handles

- Recommended for the most demanding hand cutting applications
- Heavy-duty straps support the jaws
- Maximum hardness of material to be cut: Brinell 455/Rockwell C48
- Toggle joints turn 50 lbs of hand pressure into 4000 lbs of cutting pressure
- Screw-type adjustment realigns edges
- Lockplate keeps jaws from loosening
- Designed, engineered, and manufactured in the USA
- Made in the USA
- NEVER use any H.K. Porter cutters on electrified circuits, wire, or cable!



Cat. No.	Overall Length	Soft/Medium Hard Materials (Up to Brinell 300, Rockwell C31)	Hard Materials (Up to Brinell 455, Rockwell C48)	Max. Capacity	Reinforcing Rod and Bar	Replacement Cutterhead/ Jaws Cat. No.	Product Weight
0190FCX	24 in	7/16 in, 11 mm	5/16 in, 8 mm	5/16 in, 8mm in	3/8 in, 6mm	0113CX	5.70 lb

Bolt Cutter/Cable Cutter

- Cuts soft, medium hard, and hard materials
- Cuts metal rod up to 7/16" diameter
- Cuts wire rope to 1/4" diameter
- Maximum hardness of material to be cut: Brinell 455/Rockwell C48
- Toggle joints turn 50 lbs of hand pressure into 4000 lbs of cutting pressure
- Screw-type adjustment realigns edges
- Lockplate keeps jaws from loosening
- Made in the USA
- NEVER use any H.K. Porter cutters on electrified circuits, wire, or cable!



Cat. No.	Overall Length	Soft/Medium Hard Materials (Up to Brinell 300, Rockwell C31)	Hard Materials (Up to Brinell 455, Rockwell C48)	Max. Capacity	Replacement Cutterhead /Jaws Cat. No.	Product Weight
0190MCS	24 in	7/16 in, 11 mm	5/16 in, 8 mm	7/16 in, 11 mm	0113MCS	6.40 lb

Heavy Duty Cutters

- Short-nosed jaws with high-tempered, center-cut blades
- Heavy-duty straps support the jaws
- Maximum hardness of material to be cut: Brinell 455/Rockwell C48
- Cuts hard, non-alloy chain
- Toggle joints turn 50 lbs of hand pressure into 4000 lbs of cutting pressure
- Screw-type adjustment realigns edges
- Lockplate keeps jaws from loosening
- Designed, engineered, and manufactured in the USA
- Made in the USA
- NEVER use any H.K. Porter cutters on electrified circuits, wire, or cable!



Cat. No.	Overall Length	Soft/Medium Hard Materials (Up to Brinell 300, Rockwell C31)	Hard Materials (Up to Brinell 455, Rockwell C48)	Max. Capacity	Reinforcing Rod and Bar	Replacement Cutterhead /Jaws Cat. No.	Product Weight
0190MHC	24 in	7/16 in, 11 mm	5/16 in, 8 mm	5/16 in, 8 mm	5/16 in, 8 mm	0113HC	6.30 lb
0390MHX	36 in	9/16 in, 14 mm	7/16 in, 11 mm	7/16 in, 11 mm	7/16 in, 11 mm	0313HCX	16.90 lb
0590MHX	42 in	11/16 in, 18 mm	1/2 in, 13 mm	1/2 in, 13 mm	1/2 in, 13 mm	0513HCX	18.15 lb

Compact Bolt Cutter with Plastic Dipped Handles

- Ideal for fencing work, exposed fasteners, or where near flush cut is required
- Induction hardened cutting edges for ultimate durability
- Recessed notch blade design holds cutting material close for extreme cutting power
- Easy-to-clean industrial plastic dipped handle grips
- Cuts mild steel (80,000 PSI) to 1/4", 6mm diameter
- Cuts very hard steel (285,000 PSI) to .14", 3.8mm diameter
- Angle cutter head and clipper cut blades create a near flush cut
- NEVER use any H.K. Porter cutters on energized circuits, wire, or cable!



Cat. No.	Overall Length	Cutter Head / Blades	Soft/Medium Hard Materials (Up to Brinell 300, Rockwell C31)	Hard Materials (Up to Brinell 455, Rockwell C48)	Max. Capacity	Replacement Cutterhead /Jaws Cat. No.	Product Weight
0890MA	8.5 in	Angle / Clipper	3/16 in, 5 mm	0.14 in, 3.8 mm	3/16 in, 5 mm	None	0.8 lb
0890MC	8.5 in	Straight / Center	3/16 in, 5 mm	0.14 in, 3.8 mm	3/16 in, 5 mm	None	0.8 lb

Compact Bolt Cutter with Co-Molded Handles

- Induction hardened center cut blades
- Recessed notch blade design holds cutting material close for extreme cutting power
- Heavy-duty spring creates a smooth cutting operation and is ideal for repetitive cutting
- Cuts mild steel (80,000 PSI) to 1/4", 6mm diameter
- Cuts very hard steel (285,000 PSI) to .14", 3.8mm diameter
- Co-mold handles for superior comfort with repetitive cutting
- User-friendly, robust locking device that is easy to use with gloves
- NEVER use any H.K. Porter cutters on energized circuits, wire, or cable!



Cat. No.	Overall Length	Soft/Medium Hard Materials (Up to Brinell 300, Rockwell C31)	Hard Materials (Up to Brinell 455, Rockwell C48)	Max. Capacity	Replacement Cutterhead /Jaws Cat. No.	Product Weight
0890SMC	8.5 in	3/16 in, 5 mm	0.14 in, 3.8 mm	3/16 in, 5 mm	None	0.9 lb

Shear Type Hand Operated Cable Cutters

- Shear-cut blades give clean, sharp cut with minimal distortion
- Cuts copper or aluminum, power and communications cable
- Lightweight, rugged cutter
- Drop-forged, alloy tool steel jaws with shear-cut blades
- Fiberglass handles for 2-handed control
- Made in the USA
- NEVER use any H.K. Porter cutters on electrified circuits, wire, or cable!



Cat. No.	Overall Length	Copper and Aluminum Cable, Power/Comm. Cable	Max. Capacity	Cable Capacity	Replacement Cutterhead /Jaws Cat. No.	Product Weight
0290FCS	25.5 in	1-3/8 in, 35 mm	1-3/8 in, 35 mm	1-3/8 in, 35 mm	0213CSS	4.90 lb
0390FCS	32 in	1-3/4 in, 44.5 mm	1-3/4 in, 44.5 mm	1-3/4 in, 44.5 mm	0313FCS	8.00 lb

Shear Type Cable Cutters

- Notched, shear-cut blades hold and lock cable in cutting position
- Cuts steel cable, coarse or fine stranded cable with minimal distortion
- Cuts wire rope with minimal distortion
- Toggle joints turn 50 lbs of hand pressure into 4000 lbs of cutting pressure
- Screw-type adjustment realigns edges
- Made in the USA
- NEVER use any H.K. Porter cutters on energized circuits, wire, or cable!



Cat. No.	Overall Length	Copper and Aluminum Cable, Power/Comm. Cable	Max. Capacity	Wire Rope	Cable Capacity	Replacement Cutterhead /Jaws Cat. No.	Product Weight
1490MTN	14 in	1/4 in, 6 mm	1/4 in, 6 mm	1/4 in, 6 mm	1/4 in, 6 mm	1413TN	2.80 lb
0190MTN	24 in	3/8 in, 10 mm	3/8 in, 10 mm	3/8 in, 10 mm	3/8 in, 10 mm	0113TN	5.60 lb
0390MTN	36 in	5/8 in, 16 mm	5/8 in, 16 mm	5/8 in, 16 mm	5/8 in, 16 mm	0313TN	13.00 lb

Communications Cable Cutters

- Shear-cut blades give clean, sharp cut with minimal distortion
- Cuts lead and rubber-covered communications cable only
- Do not cut hard cable, ACSR, self-supporting strand, or steel
- Made in the USA
- NEVER use any H.K. Porter cutters on energized circuits, wire, or cable!



Cat. No.	Overall Length	Copper and Aluminum Cable, Power/Comm. Cable	Max. Capacity	Cable Capacity	Replacement Cutterhead /Jaws Cat. No.	Product Weight
0390CSP	37 in	2-1/4 in, 57 mm	2-1/4 in, 57 mm	2-1/4 in, 57 mm	0319CSS	12.70 lb

ACSR, Wire Rope and Cable Cutter

- Shear-cut blades
- Cuts soft and hard steel cable, wire rope, and small ACSR cable
- Cuts Up to 3/8 in wire rope or up to 7/16 in ACSR
- Notch holds cable in blades
- Cuts copper and aluminum wire up to 1 in in size
- Steel handle with rubber grips
- NEVER Use Any H.K. Porter cutters on electrified circuits, wire, or cable!



Cat. No.	Overall Length	Copper and Aluminum Cable, All Types	Wire Rope	ACSR	Cable Capacity	Copper, Aluminum	Product Weight
0290FHJN	28 in	1 in, 25 mm	3/8 in, 10 mm	7/16 in, 11 mm	3/8 in, 10 mm	1 in, 25 mm	8.000 lb

Compact, Electric Cable Cutter

- High-leverage jaws with shear-cut blades
- Compact cutter fits into most tool pouches
- Do not cut steel or ACSR
- Industrial, non-slip grips
- NOT an insulated tool
- NEVER use any H.K. Porter cutters on energized circuits, wire, or cable!

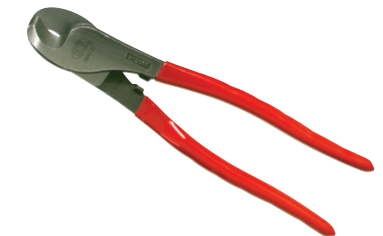

Cat. No.	Overall Length	Copper and Aluminum Cable, Power/Comm. Cable	Max. Capacity	Replacement Cutterhead/Jaws Cat. No.	Product Weight
0890CSJ	9.5 in	4/0 - Aluminum only	4/0 in	None	0.85 lb

Pocket Wire Rope and Cable Cutter

- Shear-cut blades give clean, sharp cut with minimal distortion
- Excellent cutter for 3/16 in thick hard wire rope or cable
- Cuts 1/4 in thick soft wire rope or cable, piano wire or aircraft cable
- Cuts cables up to 3/16 in [5 mm] in size
- Cuts rod up to 3/32 in [2.4 mm] in size
- Easy-to-clean industrial plastic dipped handle grips
- NEVER use any H.K. Porter cutters on electrified circuits, wire, or cable!



Cat. No.	Overall Length	Copper and Aluminum Cable, Power/Comm. Cable	Max. Capacity	Wire Rope	Cable Capacity	Rod Capacity	Replacement Cutterhead /Jaws Cat. No.	Product Weight
0690TN	7.5 in	1/4 in, 6 mm	1/4 in, 6 mm	3/16 in, 5 mm	1/4 in, 6 mm	3/32 in, 2.4 mm	None	0.80 lb

Flip Joint Cable Cutter

- 3-in-1 electrician's tool that saves time and money
- Professional cutter designed to cut vinyl-coated or bare, multi-stranded wire up to size 10/3
- Induction-hardened cutting edges for superior cutting power
- Handle flips over, turning a cable cutter into a sheath knife
- Specially designed cutting knife ensures sharp, clean cut every time
- Smart contour handles for hand comfort when cutting cable and slip resistance for slicing vinyl cable sheath
- Sharp edges for slicing vinyl-coated cable
- NEVER use any H.K. Porter cutters on energized circuits, wire, or cable!



Cat. No.	Overall Length	Copper and Aluminum Cable, Power/Comm. Cable	Max. Capacity	Cable Capacity	Replacement Cutterhead /Jaws Cat. No.	Product Weight
0890CSFW	8.375 in	10/3	1/4 in, 6 mm	1/4 in, 6 mm	None	1.45 lb

Wire Cutter

- Center cut blades
- Cuts mild steel [Brinell 140] [80,000 PSI] to 5/32" diameter
- Cuts hard steel [HRC 44] [208,000 PSI] to 3/32" diameter
- NEVER use any H.K. Porter cutters on energized circuits, wire, or cable!



Cat. No.	Overall Length	Cutter Head / Blades	Medium Steel Dia.	Hard Steel Dia.	Round Steel Tie Wire	Aircraft Cable, Hard Stainless Steel Cable	Replacement Cutterhead /Jaws Cat. No.	Product Weight
PWC9	8.5 in	Hardened Steel	5/32 in, 4 mm	3/32 in, 2.4 mm	.093 Dia. Max.	.093 Dia. Max.	None	0.72 lb

Steel Strap Cutter, 3/4"

- Sheer-cut blades give clean, smooth, easy cuts
- Lower jaw slides under the tightest strapping or staples
- Workhead has black oxide rust-resistant finish
- Spring action handles with plastisol grips open jaws automatically before and after each cut
- Cushion grip handle type with drop forged interior
- Cuts steel strap up to 3/4 in wide
- Made in the USA
- NEVER use any H.K. Porter cutters on energized circuits, wire, or cable!



Cat. No.	Overall Length	Cutter Head / Blades	Flat Steel Strap	Round Steel Tie Wire	Replacement Cutterhead /Jaws Cat. No.	Product Weight
0990T	9 in	Hardened Steel	3/4 in x .035 in, 19 mm x 1 mm	3/419.080 in, 2 mm	None	1.25 lb

Steel Strap Cutter, 1-1/4"

- Sheer-cut blades give clean, smooth, easy cuts
- Workhead has black oxide rust-resistant finish
- Cuts wide steel strap quickly and cleanly
- One-handed operation lets you make continuous cuts
- Cushion grip handles
- Made in the USA
- NEVER use any H.K. Porter cutters on energized circuits, wire, or cable!



Cat. No.	Overall Length	Cutter Head / Blades	Flat Steel Strap	Replacement Cutterhead/Jaws Cat. No.	Product Weight
1290G	12 in	Hardened Steel	1 1/4 in x .050 in, 32 mm x 1 mm	None	1.70 lb

Heavy Duty, Steel Strap Cutter, 2"

- Sheer-cut blades give clean, smooth, easy cuts
- Excellent for cutting pallet straps when loading and unloading freight cars, trucks or ships
- Cuts 2 in. x 0.05 in flat steel straps
- Long-handled, goose neck, two-hand operated cutter
- Keep hands away from cutting area
- Made in the USA
- NEVER use any H.K. Porter cutters on energized circuits, wire, or cable!



Cat. No.	Overall Length	Cutter Head / Blades	Flat Steel Strap	Replacement Cutterhead/Jaws Cat. No.	Product Weight
2690GP	24.2 in	Hardened Steel	2 in x .050 in, 51 mm x 1 mm	None	6.80 lb

Compact Ratcheting Cable Cutter

- Compact, lightweight cutter for confined spaces
- Cutter has self-lubricating ratchet and only six moving parts
- Ratchet-type jaws with shear-cut blades
- Blades grip and hold while moderate pumping action cuts cable
- Fiberglass handles with non-slip, plastic grips
- MCM capacity measurement does not include cable insulation; conductor size only
- Cuts up to 500 MCM copper cable or up to 795 MCM aluminum cable
- Made in the USA
- NEVER use any H.K. Porter cutters on energized circuits, wire, or cable!



Cat. No.	Overall Length	Cutter Head /Blades	Copper and Aluminum Cable, All Types	Copper and Aluminum Cable, Power/Comm. Cable	Replacement Cutterhead /Jaws Cat. No.	Product Weight
6990FS	14 in	Hardened Steel	1-3/16 in, 30 mm	1-3/16 in, 30 mm	None	4.15 lb

Ratchet Type, Soft Cable Cutter

- Heavy-duty jaw design
- Jaw keeper prevents jaws from spreading while under heavy load
- Cuts copper and aluminum communications power cable up to 2 in thick
- Cuts all types of copper and aluminum cables up to 2500 MCM
- Ratchet provides up to 5X the mechanical advantage over manual cutters
- Made in the USA
- NEVER use any H.K. Porter cutters on energized circuits, wire, or cable!



Cat. No.	Overall Length	Cutter Head / Blades	Copper and Aluminum Cable, All Types	Copper and Aluminum Cable, Power/Comm. Cable	Replacement Cutterhead/ Jaws Cat. No.	Product Weight
8690FSK	27.5 in	Hardened Steel	2 in, 51 mm	2 in, 51 mm	8613FSK	12.60 lb

Ratchet Type, Guy Strand Cutter

- Notched shear-cut blades hold material firmly in place
- Makes clean, square cuts with minimal distortion
- Ratchet and chain design produces easy, progressive cuts
- Cuts EHS guy strand up to 1/2 in. thick, mild steel rods and bolts, and similar materials
- Increased mechanical advantage over manual cutters
- Made in the USA
- NEVER use any H.K. Porter cutters on energized circuits, wire, or cable!



Cat. No.	Overall Length	Cutter Head/Blades	EHS Guy Strand	Common Guy Strand	Replacement Cutterhead /Jaws Cat. No.	Product Weight
8690CK	28 in	Hardened Steel	1/2 in, 13 mm	1/2 in, 13 mm	8613CK	10.34 lb

Ratchet Type, Soft Cable Cutter

- Sheer-cut blades give clean, smooth, easy cuts
- Ratchet and chain apply increased cutting pressure
- Provides increased mechanical advantage over manual cutters
- Cuts copper and aluminum
- Cuts rubber covered or lead covered power and communications cable up to 3"
- Made in the USA
- NEVER use any H.K. Porter cutters on energized circuits, wire, or cable!



Cat. No.	Overall Length	Cutter Head / Blades	Copper and Aluminum Cable, All Types	Copper and Aluminum Cable, Power/Comm. Cable	Replacement Cutterhead/ Jaws Cat. No.	Product Weight
8690CS	29.75 in	Hardened Steel	3 in, 73 mm	3 in, 73 mm	8613CS	12.60 lb

Ratchet Type, Wire Rope Cutter

- Ratchet-type jaws with notched shear-cut blades
- Blades hold and lock material in place during the cut
- Cuts aircraft cable, EHS guy strand, wire rope and stainless steel cable up to 5/8 in thick
- Cuts all strands with minimal crushing or distortion
- Increased mechanical advantage compared to manual cutters
- Made in the USA
- NEVER use any H.K. Porter cutters on energized circuits, wire, or cable!



Cat. No.	Overall Length	Cutter Head / Blades	EHS Guy Strand	Common Guy Strand	Aircraft Cable, Hard Stainless Steel Cable	Replacement Cutterhead/ Jaws Cat. No.	Product Weight
8690TN	36 in	Hardened Steel	5/8 in, 16 mm	5/8 in; 16 mm	5/8 in, 16 mm	8613TN	11.00 lb

Ratchet-Type, Hard Cable Cutter

- Sheer-cut blades give clean, smooth, easy cuts
- Jaw keeper feature prevents jaws from spreading while under heavy load
- Ratchet and chain design increase cutting pressure as handles open and close
- Increased mechanical advantage over manual cutters
- Can be used effectively with short strokes in confined spaces
- Cuts ACSR, ACAR, ZEBRA, and self-supporting telephone cable up to 1-3/16 in thick
- Not recommended for cutting insulated copper or aluminum cable
- Made in the USA
- NEVER use any H.K. Porter cutters on energized circuits, wire, or cable!



Cat. No.	Overall Length	Cutter Head / Blades	Copper and Aluminum Cable, All Types	Copper and Aluminum Cable, Power/Comm. Cable	ACSR, ACAR, ZEBRA, and Telephone Cable (Self Supporting)	Replacement Cutterhead/ Jaws Cat. No.	Product Weight
8690FH	29.25 in	Hardened Steel	1-3/16 in, 30 mm	1-3/16 in, 30 mm	1-3/16 in, 30 mm	8613FH	12.40 lb

Linkmaster® Heavy Duty Link Closer

- Heat-treated alloy steel jaws
- Opens and closes tire chain cross links
- Toggle joints turn 50 lbs hand pressure into 4000 lbs cutting pressure
- Makes repairs quickly and easily
- All steel handles
- Made in the USA
- NEVER use any H.K. Porter cutters on energized circuits, wire, or cable!



Cat. No.	Overall Length	Capacity Link Diameter	Replacement Cutterhead/Jaws Cat. No.	Product Weight
0390MLN	30 in	3/8 in; 10 mm	0313LKN	8.00 lb

SPECIALTY CUTTERS

SPECIALTY CUTTERS

Net-Link Closer for Closing Chain Links

- Used on commercial fishing boats and draggers for net and mooring chains
- Designed to close heavy chain link
- Toggle joints turn 50 lbs hand pressure into 4000 lbs cutting pressure
- Screw-type adjustment realigns edges
- Replacement cutterhead: 0213LC
- Made in the USA
- NEVER use any H.K. Porter cutters on energized circuits, wire, or cable!



Cat. No.	Overall Length	Capacity Link Diameter	Replacement Cutterhead/Jaws Cat. No.	Product Weight
0290MLC	30 in	3/8 in, 10 mm	0213LC	7.80 lb

Heavy-Duty Pneumatic Cutters

- Heavy-duty model for 90-130 PSI
- Heavy-duty workhead has 5" bore (127mm) and 3" stroke (76mm)
- Used in the wire-shelving industry
- Cuts soft, medium, or hard materials
- Center cut jaws
- Cutting controlled by manual pressure
- Filter-lubricator units recommended in air supply line for longest tool life
- No exhaust shock
- Made in the USA
- NEVER use any H.K. Porter cutters on energized circuits, wire, or cable!

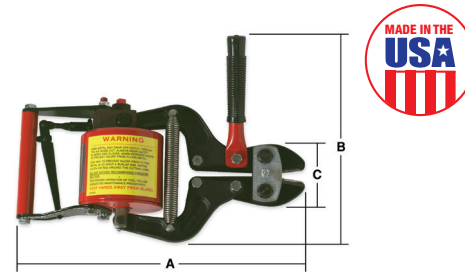

Cat. No.	Description	A	B	C	Capacity	Product Weight	Shelf Pack Qty.
9290C	Heavy Duty, Center Cut	17.5 in	10 in	3.75 in	1/2 in, 13 mm	18.25 lb	1

Light Duty Pneumatic Cutters

- Lightweight model for 80-120 PSI
- Light-duty workhead has 4" bore (102mm) and 2" stroke (51mm)
- Cuts soft, or medium materials
- Clipper cut jaws
- Cutting controlled by manual pressure
- Filter-lubricator units recommended in air supply line for longest tool life
- No exhaust shock
- Made in the USA
- NEVER use any H.K. Porter cutters on energized circuits, wire, or cable!

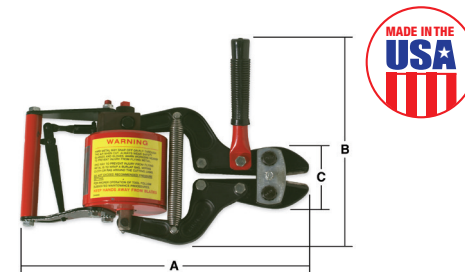

Cat. No.	Cutter Head / Blades	A	B	C	Capacity	Product Weight
9190NE	Clipper Cut	15 in	7.25 in	3.125 in	3/8 in, 10 mm	14.80 lb
9190C	Center Cut	15 in	7.25 in	3.125 in	3/8 in, 10 mm	11.00 lb

Rebar Cutter and Bender

- Shear-cut blades
- Cuts and bends to 90° or 180°
- Mounts on most flat surfaces to enhance leverage and increase safety
- Maximum rebar size capacity: 5/8 inches
- Steel construction for durability
- NEVER use any H.K. Porter cutters on electrified circuits, wire, or cable!



Cat. No.	Jaw Capacity	Overall Length	Replacement Cutterhead/Jaws Cat. No.	Product Weight
0590RBJN	.625 in	52 in	0513RBJN	44.00 lb

3/8" [#3] and 1/2" [#4] Extendable Indexing Rebar Bender

- 14-position indexing head adjusts with center push-button to allow total access for maximum leverage
- Dual-use head allows bending of both #3 and #4 rebar
- Push-button extends bender to 35 inches for maximum leverage; collapses to just 21 inches for convenient storage and portability
- Extra-sturdy steel handles for the toughest conditions
- Super-strong indexing head grips rebar securely for accurate bends
- NEVER use any H.K. Porter cutters on electrified circuits, wire, or cable!



Cat. No.	Number of Positions	Jaw Capacity	Cont. Length	Ext. Length	Product Weight
RB4	14	.375 in	22.75 in	35 in	4.70 lb

Indexing Rebar Benders

- 14-position indexing head adjusts with center push-button to allow total access for maximum leverage
- Extra-sturdy steel handles for the toughest conditions
- Super-strong indexing head grips rebar securely for accurate bends
- NEVER use any H.K. Porter cutters on electrified circuits, wire, or cable!



Cat. No.	Number of Positions	Jaw Capacity	Overall Length	Product Weight
RB5	14	.625 in	44.25 in	8.75 lb
RB6	14	.75 in	44.25 in	8.75 lb

Curved Pruner

- General purpose pruner for fast cutting of small limbs
- Popular in citrus groves and vineyards
- Silver steel® constructed blade with polished finish
- Easy to grip knife type wood handle trimmed with aluminum screws
- Full cardboard sleeve protects the blade



Cat. No.	Points Per Inch	Reverse Rip Points		Tooth Type	Blade Length	Blade Width	Overall Length	Product Weight
		Per Inch	Per Inch					
80263	6	6		Standard Hard Point	14 in	0.25	14 in	0.50 lb

Coping Saws

- Popular with carpenters and home craftsman
- Used for cutting sharp angles and curves
- Spring steel, rounded edge frame with polished finish
- Adjustable angle blade
- Straight type wood handle



Cat. No.	Points Per Inch	Reverse Rip Points		Tooth Type	Blade Length	Blade Width	Overall Length	Product Weight
		Per Inch	Per Inch					
80170	15	6		Standard Hard Point	4.25 in	0.125 in	12.5 in	0.50 lb
80176	15	8		Standard Hard Point	6.5 in	0.125 in	12.75 in	0.50 lb

Double Edge Pruner

- Lightweight economy dual-purpose pruner
- Special steel constructed blade
- Fine teeth on one edge for light trimming
- Teeth on opposite edge for heavier limbs
- Wood handle
- Plastic sleeve for blade protection



Cat. No.	Points Per Inch	Reverse Rip Points		Tooth Type	Blade Length	Blade Width	Overall Length	Product Weight
		Per Inch	Per Inch					
80269	8	4		Standard Hard Point	16 in	0.25 in	16 in	0.80 lb

Silver Flash Pruner

- Preferred by utility crews and tree surgeons
- Silver steel® constructed blade, flat ground
- Concave cutting edge has precision set and bevel filed teeth
- Teeth cut fast on the pull stroke
- Extra large teeth and gullets for speed cutting large limbs
- Wood handle
- Full cardboard sleeve protects the blade



Cat. No.	Points Per Inch	Reverse Rip Points		Tooth Type	Blade Length	Blade Width	Overall Length	Product Weight
		Per Inch	Per Inch					
80299	8	3		Standard Hard Point	26 in	0.25 in	26 in	1.50 lb

Quik-Cut Economy Handsaw

- Precision set teeth for smooth cuts
- Hardened and tempered polished steel blade
- Resharpenable teeth for long life
- Handle features 40/90 degree shape for long life



Cat. No.	Points Per Inch	Reverse Rip		Tooth Type	Blade Length	Blade Width	Overall Length	Product Weight
		Points Per Inch	Points Per Inch					
NS503N	8	8		Standard	15 in	0.03 in	15 in	0.95 lb

Predator® Handsaws

- Ergonomic handle with rubber coated grip for comfort and control
- Razor sharp diamond ground teeth for easier cuts
- Induction hardened hard point (h.p.) teeth never need sharpening
- Handle features 45/90 degree shape for marking angles



Cat. No.	Points Per Inch	Reverse Rip		Tooth Type	Blade Length	Blade Width	Overall Length	Product Weight
		Points Per Inch	Points Per Inch					
NSP1	8	4		Standard Hard Point	24 in	5.4 in	24 in	1.17 lb
NSP2	10	5		Standard Hard Point	24 in	5.4 in	24 in	1.17 lb
NSP5	8	4		Aggressive Hard Point	15 in	0.15 in	19.2 in	0.82 lb

Predator® Compass/Keyhole Saw

- Ergonomic handle with rubber coated grip for comfort and control
- Razor sharp diamond ground teeth for easier cuts
- Induction hardened hard point (h.p.) teeth never need resharpening
- Blade tapered to a point for starting holes and cutting curves



Cat. No.	Points Per Inch	Reverse Rip Points Per Inch	Tooth Type	Blade Length	Blade Width	Overall Length	Product Weight
NSP9	8	5	Hard Point	12 in	0.25 in	12 in	0.40 lb

General Purpose Hacksaw Frame

- Used on a wide variety of everyday jobs both at home and professionally
- Instantly adjustable for 10"/250mm to 12"/300mm blades
- Adjusts 90° for vertical or horizontal cuts
- Ergonomic handle ensures maximum control and comfort
- Precision engineered to provide maximum gram removal per stroke



Cat. No.	Type of Frame	Blade Length	Blade Width	Points Per Inch	Tooth Type	Overall Length	Product Weight
80951	Adjustable	10 in, 12 in	1 in	18	Standard	15.5 in	1.10 lb

High Tension Hacksaw Frame

- High-tension hacksaw frame is perfect for professional trade workers
- Quick-changing blades to let you work more efficiently
- Adjustable crank handle provides the tension for up to 30,000 psi of torque
- Spare blades can be stored inside frame for protection and transport
- Blade can be positioned for a 45° or a 90° cutting angle



Cat. No.	Type of Frame	Blade Length	Blade Width	Points Per Inch	Tooth Type	Overall Length	Product Weight
80956	High Tension Adjustable	12 in	1 in	18	Standard	16 in	1.80 lb

Cushion Grip Hacksaw Frame

- Rugged, lightweight frame built for professional tool users and trade workers
- High-tension reading and increased blade beam strength for heavy-duty work
- Compatible with high tensile strength Nicholson® Bi-Metalloy® hand hacksaw blades
- Screw operated lever allows you to tighten the blade up to 30,000 psi of tension
- Position the blade in either a 45° or 90° angle for easier angle cutting
- Spare blades can be stored inside the frame for ease of transportation and improved safety



Cat. No.	Type of Frame	Blade Length	Blade Width	Points Per Inch	Tooth Type	Overall Length	Product Weight
80965	Cushion Grip High Tension	12 in	1 in	18	Standard	17 in	2.40 lb

4-in-1 Pro Series Hacksaw Frame

- Standard 90 degree for general use
- 45 degree angle for flush cuts
- Low profile position for tight spaces
- Jab saw configuration for a variety of inside cuts
- High tension for tightening the blade up to 30,000 psi
- Cushion grip handle for better control and comfort



Cat. No.	Type of Frame	Blade Length	Blade Width	Points Per Inch	Tooth Type	Overall Length	Product Weight
80975	4-in-1 Pro Series Hacksaw	12 in	1 in	18	Standard	17 in	2.50 lb

Heavy Duty Hacksaw Frame

- High-impact, contoured handle presents an ergonomic and strong grip
- Adjust to hold a variety of blades between 10" to 12" in total length
- Adjust the blade's cutting angle up to 45° from the centerline
- Made in the USA



Cat. No.	Type of Frame	Blade Length	Blade Width	Points Per Inch	Tooth Type	Overall Length	Product Weight
80952	Adjustable	10 in, 12 in	0.50 in	18	Coarse	17.75 in	1.80 lb

Little-Nic® Utility Hacksaw

- Used on a wide variety of everyday jobs both at home and professionally
- Gets into small places, makes difficult cutting jobs easy
- Overall length 10"
- Uses any standard size hacksaw blade
- Comes complete with high quality Nicholson® blade
- Blister packed on attractive cards with suggested uses on back



Cat. No.	Points Per Inch	Tooth Type	Blade Length	Blade Width	Overall Length	Product Weight
80968	18	Standard	10 in	1 in	11 in	0.30 lb

Jab Saw

- Special saw always needed for the difficult jobs
- Designed for those hard to reach areas
- Jab saw will work with any standard size hacksaw blade
- Easily replace worn blades, simply untighten adjusting saw, remove worn blade and replace with a new Nicholson® blade, re-tighten the adjusting screw



Cat. No.	Points Per Inch	Tooth Type	Blade Length	Blade Width	Overall Length	Product Weight
80969	18	Standard	10 in	1 in	11 in	0.30 lb

6 Pc. 12" High Carbon Steel Hacksaw Blade Set

- Flexible hacksaw blades, recommended for cutting mild steel
- Hardened teeth and a flexible back, make the blades virtually unbreakable
- Includes six 12" hacksaw blades:
- Two 18 teeth per inch blades
- Two 24 teeth per inch blades
- Two 32 teeth per inch blades
- Made of high carbon steel



Cat. No.	Included Storage	Product Weight
63838	None	0.255 lb

Cat. No.	Description	Qty.
63256	Replacement Shatterproof Hacksaw Blade SS1218 12" x 18 TPI - Carded	2
63268	Replacement Shatterproof Hacksaw Blade SS1224 12" x 24 TPI - Carded	2
63280	Replacement Shatterproof Hacksaw Blade SS1232 12" x 32 TPI - Carded	2

Solid Flexible Carbon Steel Hacksaw Blades

- Solid high carbon steel
- Tempered to provide hard edge with flexible back
- Specially hardened to induce toughness
- Economy blade for sawing light to medium-hard materials
- Good balance of wear resistance, mechanical shock absorbing properties
- Virtually unbreakable
- 2 blades per card - 10 cards per bag - 40 bags per carton



Cat. No.	Overall Length	Blade Type	TPI/PPI	Gauge	Number of Blades	Product Weight
63103	10 in	Wavy	18	0.025 in	100	0.04 lb
63220	10 in	Wavy	24	0.025 in	2	0.08 lb
63112	10 in	Wavy	24	0.025 in	100	0.04 lb
63256	12 in	Wavy	18	0.025 in	2	0.09 lb
63145	12 in	Wavy	18	0.025 in	100	0.04 lb
63268	12 in	Wavy	24	0.025 in	2	0.05 lb
63158	12 in	Wavy	24	0.025 in	100	0.04 lb
63280	12 in	Wavy	32	0.025 in	2	0.10 lb

Bowsaw Replacement Blade

- Used for smooth cutting of paneling, plywood and laminates
- Flat ground
- Made from finest alloy saw steel
- Stays sharper longer, resists rust
- Easily resharpened
- Cuts smoother with less friction

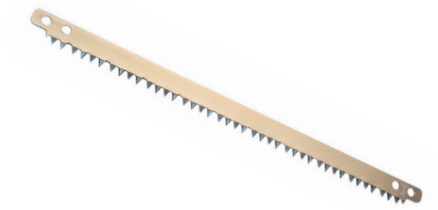

Cat. No.	Blade Type	TPI/PPI	Blade Length	Blade Width	Overall Length	Product Weight	Shelf Pack Qty.
80814	Wavy	4	12 in	0.79 in	12 in	0.75 lb	10

Bi-Metalloy® Hacksaw Blades

- Molybdenum alloy tool steel edge
- Tough flexible high carbon steel backing
- Lasts twice as long as high-speed steel
- Lasts up to ten times longer than carbon steel
- Operates 20% to 50% faster
- High tooth hardness and shock resistance
- 2 Blades per card - 10 cards per bag - 40 bags per carton



Cat. No.	Overall Length	Blade Type	TPI/PPI	Gauge	Blades	Product Weight
62811N-02	10 in	Wavy	18	0.025 in	10	0.100 lb
62635N-02	10 in	Wavy	18	0.025 in	100	0.040 lb
62830N-02	10 in	Wavy	24	0.025 in	10	0.100 lb
62706N-02	12 in	Raker	14	0.025 in	100	0.044 lb
62826N-02	12 in	Wavy	18	0.025 in	10	0.106 lb
62723N-02	12 in	Wavy	18	0.025 in	100	0.044 lb
62832N-02	12 in	Wavy	24	0.025 in	10	0.106 lb
62749N-02	12 in	Wavy	24	0.025 in	100	0.044 lb
62839N-02	12 in	Wavy	32	0.025 in	10	0.106 lb
62776N-02	12 in	Wavy	32	0.025 in	100	0.044 lb
62838N-02	12 in	Wavy	18/24/32	0.025 in	10	0.280 lb



Measuring

- Tapes • Wheels • Long Tapes • Squares & Rules
- Chalk & Reel • Oil Gauging • Accessories



A1 YELLOW CLAD

- Black and red markings one side only
- Graduated feet and inches to 1/16ths top edge
- Graduated inches to 1/16ths bottom edge, first 12" to 1/32nds
- Instantaneous foot readings
- Stud marks every 16"



A2 YELLOW CLAD

- Black and red markings one side only
- Graduated feet and inches to 1/16ths top edge
- Graduated inches to 1/16ths bottom edge, first 12" to 1/32nds
- Instantaneous foot readings
- Stud marks every 16"



A11 YELLOW CLAD

- Black and red markings one side only
- Top edge graduated and numbered inches (no stud centers)
- Bottom edge graduated in millimeters, numbered consecutive millimeters with red number at each decimeter
- Stud marks every 16" and 40cm



A12 YELLOW CLAD

- Black and red markings one side only
- Top edge to 1/16ths, continuous inches; feet and decimeters marked in red
- Bottom edge graduated to millimeters, numbered consecutive centimeters



A3 YELLOW CLAD

- Graduated feet and inches to 1/16ths top and bottom edge
- Vertical numbering
- Fractional and decimal equivalent marking
- Stud marks every 16"

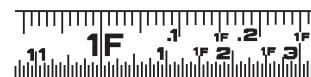

A4 YELLOW CLAD

- Graduated feet, 1/10ths and 1/100ths top edge; feet, inches and 1/16ths on bottom edge
- Instantaneous foot readings
- Stud marks every 16"



A13 YELLOW CLAD

- Black markings one side only
- Consecutive inches to 1/16ths bottom edge, first 12" to 1/32nds
- Stud marks every 16" and 40cm

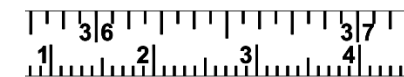

A14 YELLOW CLAD

- Black markings one side only
- Top edge graduated in inches to 1/16ths
- Bottom edge graduated in millimeters, numbered in centimeters; 1 to 9 in each decimeter



A5 YELLOW CLAD AND BLACK

- Black and red markings one side only
- Consecutive inches to 16ths
- Stud marks every 16", Truss marks every 19.2"
- Instantaneous foot readings



A6 CHROME CLAD®

- Chrome Clad® blade
- Black markings one side only
- Graduated to 1/10ths of inches on both edges



A15 YELLOW CLAD

- Black markings both sides
- Consecutive inches to 1/16ths, first 12" to 1/32nds on side 1
- Diameter inches to 1/64ths side 2; blank space ahead of zero



A16 YELLOW CLAD

- Markings both sides
- Consecutive inches to 1/16ths, first 12" to 1/32nds on side 1
- Diameter inches to 1/100ths side 2; blank space ahead of zero



A7 YELLOW CLAD

- Black markings one side only
- Graduated to 1/10ths of inches on both edges
- First 6" on bottom edge graduated to 1/50ths



A8 CHROME CLAD®

- Chrome Clad® blade
- Black markings one side only
- Graduated consecutive inches and 1/16ths on top and bottom edges

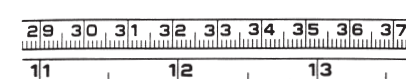

A17 YELLOW CLAD

- Markings both sides
- Consecutive centimeters to millimeters on side 1
- Diameter to millimeters side 2, numbered in centimeters

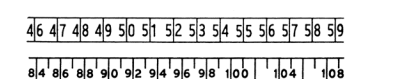

A18 YELLOW CLAD

- Black markings both sides
- One side marked 1/4th scale [1 to 240], other side has 1/8th scale [1 - 480]



A9 YELLOW CLAD

- Black and red markings one side only
- Both edges graduated to millimeters; numbered consecutive centimeters with larger red numbers at each decimeter

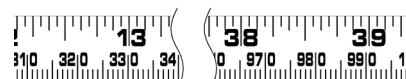

A10 YELLOW CLAD

- Black and red markings one side only
- Top edge graduated and numbered inches
- Bottom edge to millimeters, numbered consecutive millimeters with red number at each decimeter

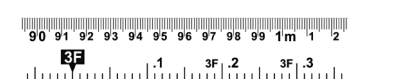

A19 YELLOW CLAD

- Black and red markings one side only
- Graduated millimeters on top edge and feet
- 1/10ths and 1/100ths on bottom edge



A20 YELLOW CLAD

- Markings one side only
- English top edge to 1/16ths, first 12" to 1/32nds, (continuous inches plus consecutive inch marks within each foot from 1' mark)
- Truss marks every 19.2"
- Metric bottom edge graduated to millimeters, numbered consecutive centimeters

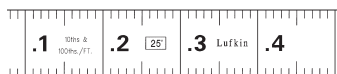

A21 YELLOW CLAD

- Black and red markings one side only
- Graduated in feet, 1/10ths and 1/100ths of feet, numbered in feet and 10ths of feet

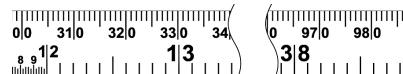

A22 YELLOW CLAD

- Black and red markings one side only
- Top edge numbered every 10 millimeters with red print for every 100cm increment and graduations every millimeter
- Bottom edge numbered in consecutive inches graduated in 1/10ths of an inch with first 12" graduated to 1/50ths and numbered in 10ths



B1 YELLOW CLAD

- 3/8" width only
- Yellow clad blade
- Black and red markings one side only
- Graduated feet and inches to 1/8ths with instantaneous readings; 16" centers indicated by a diamond



B2 CHROME CLAD®

- 3/8" width only
- Chrome Clad® blade
- Black markings one side only
- Graduated feet and inches to 1/16ths with instantaneous readings



A23 YELLOW CLAD

- Black and red markings one side only
- Top edge graduated to 1/16ths, and numbered in consecutive inches and fractional equivalents to 1/8ths.
- Bottom edge with red print numbered at the mid-point of the measurement on the top edge



A24 YELLOW CLAD

- Two sided, extra-large black and red markings
- Contrasting Color blocks extending from 1/2" prior to each foot mark to 1/2" after each foot mark
- Consecutive inches to 16ths
- Stud marks every 16", Truss marks every 19.2"
- Instantaneous foot readings



B3 CHROME CLAD® & NUBIAN®

- 3/8" width only
- Chrome Clad® and Nubian® blade
- Black markings one side only
- Graduated consecutive inches to 1/16ths

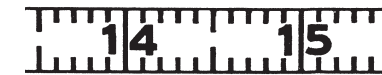

B4 CHROME CLAD®

- 3/8" width only
- Chrome Clad® blade
- Black markings one side only
- Graduated consecutive inches to 1/10ths



A25 YELLOW CLAD

- Two sided, extra-large black and red markings
- English top edge to 1/16ths; metric bottom edge graduated to millimeters, numbered consecutive centimeters
- Stud marks every 16" [40cm], Truss marks every 19.2"
- Instantaneous foot readings



A26 BLACK BLADE

- Two sided, extra-large, contrasting green markings on black blade
- Contrasting Color blocks extending from 1/2" prior to each foot mark to 1/2" after each foot mark
- Consecutive inches to 16ths
- Stud marks every 16", Truss marks every 19.2"
- Instantaneous foot readings



B5 CHROME CLAD® & YELLOW CLAD

- 3/8" width only
- Chrome Clad® and yellow clad blade
- Black markings one side only
- Graduations feet to 1/10ths and 1/100ths



B7 CHROME CLAD® & NICKEL CLAD®

- 3/8" width only
- Chrome Clad®, nickel clad and yellow clad blade
- Black markings one side only
- Graduated feet and inches to 1/8ths with instantaneous readings; 16" centers indicated by diamond



A27 BLACK BLADE

- Two sided, extra-large, contrasting green markings on black blade
- English top edge to 1/16ths; metric bottom edge graduated to millimeters, numbered consecutive centimeters
- Stud marks every 16" [40cm], Truss marks every 19.2"
- Instantaneous foot readings



A28 YELLOW CLAD

- Single side, extra-large black and red markings
- English top edge to 1/16ths; metric bottom edge graduated to millimeters, numbered consecutive centimeters
- Stud marks every 16" [40cm], Truss marks every 19.2"
- Instantaneous foot readings



B8 YELLOW CLAD

- 3/8" width only
- Yellow clad blade
- Black and red markings both sides
- Bottom side graduated millimeters, numbered in centimeters and meters
- Top side graduated feet and inches to 1/8ths with instantaneous readings; 16" centers indicated by a diamond

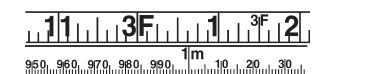

B9 YELLOW CLAD

- 3/8"/10mm width only
- Yellow clad blade
- Black and red markings both sides
- One side graduated feet and inches to 1/8ths with instantaneous readings; other side graduated in consecutive millimeters with instantaneous meter numbers at every 100mm



A29 YELLOW CLAD

- Black and red markings one side only
- Graduated feet and inches to 1/16ths, first 12" to 1/32nds
- Instantaneous foot readings
- Stud marks every 16", Truss marks every 19.2"



A30 YELLOW CLAD

- Black and red markings one side only
- English top edge to 1/16ths, first 12" to 1/32nds
- Bottom edge graduated to millimeters, numbered consecutive centimeters
- Stud marks every 16" [40cm], Truss marks every 19.2"
- Instantaneous foot readings

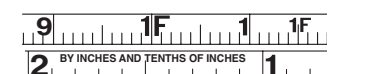

B10 CHROME CLAD® & NUBIAN®

- 3/8" width only
- Nubian® and Chrome Clad® blade
- Markings both sides
- One side graduated 1/10ths and 1/100ths of feet; other side diameter feet and 1/10ths of inches



B11 NUBIAN®

- 3/8" width only
- Nubian® blade
- Markings both sides
- Graduated feet, inches and 1/8ths one side; other side graduated diameter feet and inches with an extra diameter inch subdivided to 64ths left hand



B12 YELLOW CLAD

- 3/8" width only
- Yellow clad blade
- Black and red markings one side only
- Graduated feet and inches to 1/8ths with instantaneous readings; 16" centers indicated by a diamond



B14 CHROME CLAD®

- 3/8" width only
- Chrome Clad® blade
- Black markings one side only
- Graduated feet and inches to 1/16ths with instantaneous readings



C11 YELLOW CLAD & WHITE CLAD

- 3/4" width only
- White on top, yellow on bottom
- Black and red markings both sides
- Two-sided tapeline; top side feet and inches, graduated to 8ths; bottom decimal feet

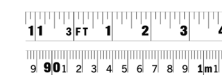

C12 YELLOW CLAD & WHITE CLAD

- 3/4" width only
- White on top, yellow on bottom
- Black and red markings both sides
- Two-sided tapeline; top side graduated in millimeters, numbered centimeters with meters, bottom in feet and inches



B15 CHROME CLAD® & NUBIAN®

- 3/8" width only
- Chrome Clad® and Nubian® blade
- Black markings one side only
- Graduated consecutive inches to 1/16ths



C1 YELLOW CLAD

- 1/2" width only
- Yellow clad blade
- Black and red markings one side only
- Graduated feet and inches to 1/8ths; numbered with feet and instantaneous foot markings in red and inches in black



D1 CHROME CLAD® & NUBIAN®

- 1/2" width only
- Markings one side only
- Graduated instantaneous feet and inches to 1/8ths



D2 CHROME CLAD® & NUBIAN®

- 1/2" width only
- Markings one side only
- Graduated in feet to 1/10ths and 1/100ths of an foot; reads right to left



C2 YELLOW CLAD

- 1/2" width only
- Yellow clad blade
- Black and red markings one side only
- Graduated feet to 1/10ths and 1/100ths; numbered with feet in red and 1/10ths of feet in black



C3 YELLOW CLAD

- 13mm width only
- Yellow clad blade
- Black and red markings one side only
- Graduated millimeters, numbered at each centimeter with red instantaneous meter number



D3 CHROME CLAD® & NUBIAN®

- 1/2"/13mm width only
- Markings both sides
- Graduated in millimeters on one side; other side instantaneous feet and inches to 1/8ths



D4 CHROME CLAD® & STAINLESS STEEL

- 1/2" width only
- Markings one side only
- Graduated feet and inches to 1/8ths; instantaneous foot readings

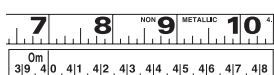

C4 YELLOW CLAD

- 1/2"/13mm width only
- Yellow clad blade
- Black and red markings on both sides
- Two-sided tapeline; top side in feet, inches, and 1/8ths, numbered at each foot with red instantaneous foot numbers; bottom side graduated in millimeters, numbered centimeters with red instantaneous meter number



C5 WHITE CLAD

- White clad blade
- 5/8" width
- Black and red markings one side only
- Graduated feet and inches to 1/8ths, red feet numbers and black inch numbers



D5 NUBIAN®

- 1/2" width only
- Nubian® blade
- Markings one side only
- Graduated feet and inches to 1/8ths; instantaneous foot readings

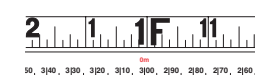

D6 CHROME CLAD®

- 1/2"/13mm width
- Chrome Clad® blade
- Black and red markings on metric side
- Metric - graduated meters to millimeters; numbered right to left in meters and millimeters
- English side - graduated feet and inches to 1/8ths; numbered right to left



C6 WHITE CLAD

- White clad blade
- 5/8" width
- Black and red markings one side only
- Graduated feet to 1/10ths and 1/100ths, red feet numbers and black tenths of feet numbers



C7 YELLOW CLAD

- 1/2"/13mm width only
- Yellow clad blade
- Black and red markings on both sides
- Two-sided tapeline; bottom side in metric, graduated in millimeters, numbered in centimeters, with red instantaneous meter number; top side graduated feet to 1/10ths and 1/100ths, numbered with feet in red and 10ths of feet in blade



D7 NUBIAN®

- 1/2" width only
- Nubian® blade
- Graduated in meters; numbered in millimeters



E1 CHROME CLAD® & YELLOW CLAD

- 1/4" and 3/8" widths
- Chrome Clad® and yellow clad blade
- Markings on one side only
- Graduated to feet, 1/10ths and 1/100ths with a blank space at last end



E3 CHROME CLAD® & YELLOW CLAD

- 1/4" and 3/8" widths
- Chrome Clad® blade
- Yellow clad available in 1/4" only
- Black markings one side only
- Graduated feet and inches to 1/8ths with instantaneous readings
- 16" centers indicated by a diamond symbol on 3/8" width only



E5 NY-CLAD® YELLOW

- 1/2" width only
- Nylon-clad yellow blade
- Black and red markings one side only
- Graduated feet to 1/10ths and 1/100ths
- Numbered with feet in red and 1/10ths in black

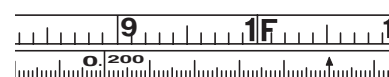

E12 CHROME CLAD®

- 1/4" width
- Black and red markings one side; black markings other side
- Graduated meters to millimeters one side
- Red meter numbers and black millimeter numbers at each decimeter
- Graduated feet to 1/10ths and 1/100ths other side
- Numbered feet and 1/10ths black markings only



E2 CHROME CLAD®

- 1/4"/6mm width only
- Chrome Clad® blade
- Markings on both sides
- Graduated millimeters one side
- Graduated feet, inches and 1/8ths other side



E4 NY-CLAD® YELLOW

- 1/2" width only
- Nylon-clad yellow blade
- Black and red markings one side only
- Graduated feet and inches to 1/8ths with instantaneous readings
- Numbered with feet and instantaneous foot markings in red and inches in black



E11 CHROME CLAD®

- 6mm width
- Black and red markings one side only
- Graduated meters to millimeters
- Red meter numbers and black millimeter numbers at each decimeter



E13 CHROME CLAD®

- 1/4" width
- Black and red markings both sides
- Graduated meters to millimeters one side
- Red meter numbers and black millimeter numbers at each decimeter
- Graduated feet and inches to 1/8ths other side with red feet numbers and black inch numbers

Crescent Lufkin Shockforce™ and Shockforce Nite Eye™ Measuring Tapes

Introducing the toughest tapes to ever hit a jobsite. Shockforce brings new meaning to the term high performance with a full 14 feet* of standout and the ability to survive a 100-foot drop. Add in a diamond coated 360-degree end hook that delivers 50% more gripping power, a two-sided blade with vertical markings on the back, and class-leading ergonomics and you have a tape that's destined to be the new standard for trade professionals.

But that's not all. There's also the Shockforce Nite Eye, with all the capabilities of the original Shockforce plus the Nite Eye high visibility green-on-matte black blade. Made for superior legibility in any light condition – from bright sun to dim interiors – Shockforce Nite Eye helps you measure even faster.

NYLON
5X
BLADE LIFE
COATING

2-SIDED
BLADES

TETHER
READY

Superior Impact Protection
Dual metal guardrails on both sides of the lock button provide superior protection

Integrated Thru-Hole
Can be used as a tether loop attachment point when working at height or as a pivot for scribing arcs

High Visibility No-Glare Blade
High-contrast green markings and matte finish provide improved legibility in all light conditions

Durable Nylon Blade Coating
Best-in-class blade protection, extending blade life 5X vs. standard uncoated blades

360-Degree End Hook
Diamond abrasive-coated, our end hook grips surfaces better to save time when measuring

Easier Inside Measurements
25-foot tapes have an even 3-inch adder, making inside measurement calculations fast and easy



*at maximum performance

Shockforce Nite Eye™ Tape Measures

- Matte black nylon-coated blade provides extended product life and improved legibility in varied light conditions
- Diamond-coated end hook grabs material from every direction and prevents slippage
- Narrow blade technology offers reduced weight for carrying
- Optimized drum and spring design provides a compact case that fits comfortably in the palm of your hand
- Drop tested from 100 feet for real life, on the job durability
- Dual-sided blade printed with vertical quick read scale on underside for overhead and hard-to-reach measurements
- Full 14 feet of standout
- Steel tether point offers increased safety capability when working at height
- Tether point can also be used for scribing and drawing arcs during layout



Cat. No.	Case Color	Blade Width	Blade Length	Blade Style	Magnetic	Standout	Product Weight
L1116B	Black	1-3/16 in	16 ft	A26	No	14 ft	.93 lb
L1125B	Black	1-3/16 in	25 ft	A26	No	14 ft	1.21 lb
L1135B	Black	1-3/16 in	35 ft	A26	No	14 ft	1.56 lb

Shockforce™ Tape Measures

- Matte nylon-coated blade provides extended product life and glare reduction
- Diamond-coated end hook grabs material from every direction and prevents slippage
- Narrow blade technology offers reduced weight for carrying
- Optimized drum and spring design provides a compact case that fits comfortably in the palm of your hand
- Drop tested from 100 feet for real life, on the job durability
- Dual-sided blade printed with vertical quick read scale on underside for overhead and hard-to-reach measurements
- Full 14 feet of standout
- Steel tether point offers increased safety capability when working at height
- Tether point can also be used for scribing and drawing arcs during layout



Cat. No.	Case Color	Blade Width	Blade Length	Blade Style	Magnetic	Standout	Product Weight
L1116	Rawhide Orange	1-3/16 in	16 ft	A24	No	14 ft	.93 lb
L1125	Rawhide Orange	1-3/16 in	25 ft	A24	No	14 ft	1.21 lb
L1135	Rawhide Orange	1-3/16 in	35 ft	A24	No	14 ft	1.56 lb
L1116CME	Rawhide Orange	30 mm, 1-3/16 in	5 m, 16 ft	A25	No	14 ft	.93 lb
L1125CME	Rawhide Orange	30 mm, 1-3/16 in	8 m, 26 ft	A25	No	14 ft	1.21 lb
L1135CME	Rawhide Orange	30 mm, 1-3/16 in	10 m, 33 ft	A25	No	14 ft	1.56 lb

Shockforce Nite Eye™ Tape Measure Keychain

- Innovative blade synonymous with Crescent Lufkin Nite Eye family
- 360-degree, 8' matte black blade with green markings for increased legibility
- 360° mini endhook with wide base makes grabbing surfaces easier
- Full loop keychain for securing tape



Cat. No.	Case Color	Blade Width	Blade Length	Magnetic	Packaging	Product Weight
L1108B	Black	1/2 in	8 ft	No	Fishbowl	0.135 lb

Tape Measure Keychains

- Compact case fits easily in bags or pockets
- Integrated D-ring with keychain attachment for carrying or storing
- Protective clear coat over the blade and markings extends tape life
- Blade graduations printed in inches and 1/8ths
- Extra wide end hook stays in place better for easier marking
- Over 3 feet of blade standout



Cat. No.	Case Color	Blade Width	Blade Length	Magnetic	Packaging	Product Weight
CS8506	Rawhide Orange	1/2	6 ft	No	Fishbowl	0.135 lb
CS8506MP	Rawhide Orange	1/2 in	6 ft	No	Merchandiser	0.140 lb

Command Control Series™ Tape Measures

- Anti-pinch, finger tip control feature for increased control when retracting
- Protected lock button and 6-point dual material case for increased durability
- Matte clear protective blade coating for better visibility and durability
- 360-degree end hook and 12-foot standout make one-person use easier
- Tether hole for safely working at heights



Cat. No.	Blade Description	Case Color	Blade Width	Blade Length	Blade Style	Magnetic	Standout	Product Weight
L1016C	Standard	Black	1-3/16 in	16 ft	A5	No	12 ft	0.940 lb
L1025C	Standard	Black	1-3/16 in	25 ft	A5	No	12 ft	1.280 lb
L1030C	Standard	Black	1-3/16 in	30 ft	A5	No	12 ft	1.600 lb
L1035C	Standard	Black	1-3/16 in	35 ft	A5	No	12 ft	1.700 lb
L1025CB	Standard Black	Black	1-3/16 in	25 ft	A5	No	12 ft	1.280 lb
L1025CME	Metric English	Black	30 mm, 1-3/16 in	8 m, 26 ft	A28	No	12 ft	1.320 lb
L1035CME	Metric English	Black	30 mm, 1-3/16 in	10 m, 33 ft	A28	No	12 ft	1.700 lb
L1025CD	Engineer's Scale	Black	1-3/16 in	25 ft	A4	No	12 ft	1.280 lb

Experience Control for Yourself: Control Series Tape Measures

The Crescent Lufkin Control Series is right at home in the hands of professionals who want a tape measure that works as hard as they do. The 1-3/16" wide tape with extra-large print has 12 feet of true standout to tackle any job, and the matte finish both reduces glare and protects the blade, ensuring that it holds up through heavy use. The finger brake beneath the tape's feed allows the user to control the blade without risk of pinching, and the blade can be locked in place with the wide lock button protected by over-mold rails.

Of course, the best-in-class durability of the Control Series doesn't stop at the lock button rails — the ergonomic case survived 50+ 1-story drops in real life strength testing. The Control Series excels, from the integrated tether point to the 360° grip end hook. See for yourself why Crescent is Trusted by the Trades; try the new Crescent Lufkin Control Series for yourself today.

Ergonomic Case

Professionally designed for easier use and more comfortable handling with touch point texture for increased grip

Lock Button Rails

Over-mold rails protect the lock button during drops for improved durability and product life



360-Degree Endhook
Grips material from all sides for more efficient measuring

Tether Point

Integrated slot for tethering tape when working at height

Finger Brake

Allows user to safely control blade retraction without pinching fingers

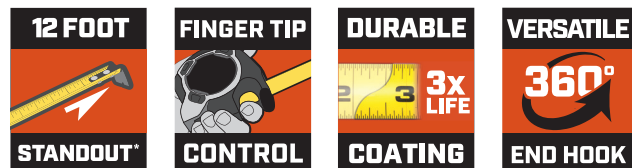

L9000 Legacy Series Power Tapes

- Extra-wide lock button for easy thumb actuation
- Matte finish, nylon coated blade for glare reduction and extra blade protection
- Reinforced quad-rivet end hook prevents end hook from ripping off of blade
- Over 8 feet of blade standout
- Blade graduated in 32nds for first 12 inches



Cat. No.	Case Color	Blade Width	Blade Length	Blade Style	Magnetic	Standout	Product Weight
L912	Chrome	3/4 in	12 ft	A29	No	8 ft	0.395 lb
L916L	Chrome	1 in	16 ft	A29	No	8 ft	0.620 lb
L925L	Chrome	1 in	25 ft	A29	No	8 ft	0.910 lb
L930L	Chrome	1 in	30 ft	A29	No	8 ft	0.990 lb
L935L	Chrome	1 in	35 ft	A29	No	8 ft	1.270 lb

700 Series Auto-Lock Tape Measures

- Tape stays locked when pulled out until the user depresses the release button
- Ideal for layout and trim work
- Vertical quick read scale on blade
- Case designed to fit comfortably in your hand
- Distinct Crescent rawhide orange case with overmold strip helps identify tape on crowded jobsite



Cat. No.	Case Color	Blade Width	Blade Length	Blade Style	Magnetic	Standout	Product Weight
AL725N	Rawhide Orange	1 in	25 ft	A3	No	8 ft	0.860 lb
AL725MAGN	Rawhide Orange	1 in	25 ft	A3	Yes	8 ft	0.880 lb
AL748CMEN	Rawhide Orange	25 mm, 1 in	8 m, 26 ft	A12	No	8 ft	0.900 lb

700 Series Magnetic End Hook Tape Measures

- Use for one-man measurements of steel framing and drop ceiling grids
- Magnetic end hook for grasping metal surfaces
- Powerful dual magnets can also serve as a pick-up tool
- Protective overmold layer improves case strength when dropped
- Distinct Crescent rawhide orange case with overmold strip helps identify tape on crowded jobsite



Cat. No.	Case Color	Blade Width	Blade Length	Blade Style	Magnetic	Standout	Product Weight
L725MAG	Rawhide Orange	1 in	25 ft	A5	Yes	8 ft	0.80 lb
L748MAG	Rawhide Orange	25 mm, 1 in	8 m, 26 ft	A20	Yes	8 ft	0.80 lb

700 Series Self-Centering Tape Measure

- Self-centering tape blade identifies the center of a measurement
- Improved design and ergonomics for a modern look and feel
- Clear coating extends life of blade and blade markings
- Reinforced quad-rivet end hook prevents end hook from ripping off of blade



Cat. No.	Case Color	Blade Width	Blade Length	Blade Style	Replacement Blade No.	Magnetic	Product Weight
L725SCTMPN	Rawhide Orange	1 in	25 ft	A23	None	No	0.830 lb

L600N Series Power Tapes

- Textured case for easier grip and increased user comfort
- Compact case size fits nicely into a tape holder or pocket
- Matte blade finish reduces glare and improves legibility of blade markings
- Clear coating extends life of blade and blade markings
- Serrated end hook tips allow users to mark measurements without a writing utensil



Cat. No.	Case Color	Blade Width	Blade Length	Blade Style	Magnetic	Product Weight
L610N	Rawhide Orange	1/2 in	10 ft	A5	No	0.240 lb
L616N	Rawhide Orange	3/4 in	16 ft	A5	No	0.460 lb
L625N	Rawhide Orange	1 in	25 ft	A5	No	0.780 lb
L610CMEN	Rawhide Orange	13 mm, 1/2 in	3 m, 10 ft	A12	No	0.240 lb
L616CMEN	Rawhide Orange	19 mm, 3/4 in	5 m, 16 ft	A12	No	0.460 lb
L625CMEN	Rawhide Orange	25 mm, 1 in	8 m, 26 ft	A12	No	0.780 lb

Quickread® Tape Measures

- Ergonomic case design for better fit in-hand during measuring
- Overmold case protects the tape from impact and makes it easier to grip
- Toggle lock positioned on top of the tape doesn't require sliding to lock
- Graduations printed in fractions and decimal equivalents, then vertically oriented for quicker measurement reading



Cat. No.	Case Color	Blade Width	Blade Length	Blade Style	Magnetic	Standout	Product Weight
PQR1312N	Rawhide Orange	3/4 in	12 ft	A3	No	-	0.60 lb
PQR1316N	Rawhide Orange	3/4 in	16 ft	A3	No	-	0.62 lb
PQR1425N	Rawhide Orange	1 in	25 ft	A3	No	8 ft	1.07 lb
QRL625MP	Blue	1 in	25 ft	A3	No	-	0.80 lb

PHV Series Tape Measures

- Ergonomic case design for better fit in-hand during measuring
- Overmold case protects the tape from impact and makes it easier to grip
- Toggle lock positioned on top of the tape doesn't require sliding to lock
- Reinforced quad-rivet end hook prevents end hook from ripping off of blade



Cat. No.	Case Color	Blade Width	Blade Length	Blade Style	Magnetic	Standout	Product Weight
PHV1010N	Rawhide Orange	1/2 in	10 ft	A1	No	-	0.29 lb
PHV1012N	Rawhide Orange	1/2 in	12 ft	A1	No	-	0.32 lb
PHV1023CMEN	Rawhide Orange	13 mm, 1/2 in	3 m, 10 ft	A20	No	-	0.29 lb
PHV1023CMN	Rawhide Orange	13 mm, 1/2 in	3 m, 10 ft	A9	No	-	0.29 lb
PHV1024CMEN	Rawhide Orange	13 mm, 1/2 in	4 m, 13 ft	A20	No	-	0.32 lb
PHV1034CMEN	Rawhide Orange	19 mm, 3/4 in	4 m, 13 ft	A20	No	-	0.60 lb
PHV1034DMN	Rawhide Orange	19 mm, 3/4 in	3.7 m, 12 ft	A19	No	-	0.60 lb
PHV1035CMEN	Rawhide Orange	19 mm, 3/4 in	5 m, 16 ft	A20	No	8 ft	0.62 lb
PHV1035CMN	Rawhide Orange	19 mm, 3/4 in	5 m, 16 ft	A9	No	-	0.62 lb
PHV1048CMEN	Rawhide Orange	25 mm, 1 in	8 m, 26 ft	A20	No	8 ft	1.07 lb
PHV1048CMN	Rawhide Orange	25 mm, 1 in	8 m, 26 ft	A9	No	8 ft	1.07 lb
PHV1048DMN	Rawhide Orange	25 mm, 1 in	7.6 m, 25 ft	A19	No	8 ft	1.07 lb
PHV1049CMEN	Rawhide Orange	25 mm, 1 in	9 m, 30 ft	A20	No	8 ft	0.76 lb
PHV1312DN	Rawhide Orange	3/4 in	12 ft	A4	No	-	0.60 lb
PHV1312N	Rawhide Orange	3/4 in	12 ft	A2	No	-	0.60 lb
PHV1316N	Rawhide Orange	3/4 in	16 ft	A2	No	-	0.62 lb
PHV1410CMEN	Rawhide Orange	25 mm, 1 in	10 m, 33 ft	A20	No	8 ft	1.34 lb
PHV1425DN	Rawhide Orange	1 in	25 ft	A4	No	8 ft	1.07 lb
PHV1425EDN	Rawhide Orange	1 in	25 ft	A21	No	8 ft	1.07 lb
PHV1425N	Rawhide Orange	1 in	25 ft	A5	No	8 ft	1.07 lb
PHV1430N	Rawhide Orange	1 in	30 ft	A5	No	8 ft	0.76 lb
PHV1433DMN	Rawhide Orange	25 mm, 1 in	10 m, 33 ft	A19	No	8 ft	1.34 lb
PHV1433N	Rawhide Orange	1 in	33 ft	A5	No	8 ft	1.34 lb

P Series Tape Measure

- Ergonomic case design for better fit in-hand during measuring
- Toggle lock positioned on top of the tape doesn't require sliding to lock
- Multi-riveted end hook for added durability
- Compact chrome-finished case



Cat. No.	Case Color	Blade Width	Blade Length	Blade Style	Magnetic	Standout	Product Weight
P2212XN	Chrome	1/2 in	12 ft	A7	No	-	0.32 lb
P2210MEXN	Chrome	13 mm, 1/2 in	3 m, 10 ft	A22	No	-	0.29 lb
P2335MEN	Chrome	19 mm, 3/4 in	5 m, 16 ft	A12	No	-	0.62 lb
P2133DN	Chrome	1 in	33 ft	A4	No	8 ft	1.72 lb

Mezurall™

- Square case design lets you include the case in the measurement for easy inside measures
- Dual rivet end hook for added durability
- Metal belt clip for easily attaching to belt or pants pocket



Cat. No.	Case Color	Blade Width	Blade Length	Blade Style	Product Weight
W928	Chrome	1/2 in	8 ft	A1	0.20 lb
W9210	Chrome	1/2 in	10 ft	A1	0.30 lb
W9212	Chrome	1/2 in	12 ft	A1	0.26 lb
W9210ME	Chrome	13 mm, 1/2 in	3 m, 10 ft	A10	0.24 lb
W9312	Chrome	3/4 in	12 ft	A2	0.40 lb
W9312D	Chrome	3/4 in	12 ft	A4	0.38 lb
Y8210	Black	1/2 in	10 ft	A1	0.20 lb
Y8212	Black	1/2 in	12 ft	A1	0.24 lb

Mezurall™ Chrome Clad®

- Chrome plated case
- Ideal for industrial use
- Hard chrome plated blade is tough and accurate
- 1/2" X 12' Chrome Clad® blade



Cat. No.	Case Color	Blade Width	Blade Length	Blade Style	Product Weight
C9212X	Chrome	1/2 in	12 ft	A6	0.30 lb
C9212	Chrome	1/2 in	12 ft	A8	0.30 lb

Pee Wee™

- Pocket size ideal for office or home
- High strength case
- Yellow clad blade
- 1/4" / 6mm wide blade is flexible; bold graduations on yellow background



Cat. No.	Case Color	Blade Width	Blade Length	Blade Style	Product Weight
W616	Black	1/4 in	6 ft	A13	0.10 lb
W6110	Black	1/4 in	10 ft	A13	0.12 lb
Y613ME	Black	6 mm, 1/4 in	3 m, 10 ft	A14	0.05 kg
W616B0	Orange	1/4 in	6 ft	A13	0.00 lb

Executive® ThinLine

- Convenient for office, briefcase, or pocket
- 6' easy-to-read blade
- Power retraction



Cat. No.	Case Color	Blade Width	Blade Length	Blade Style	Product Weight
W606	Chrome	1/4 in	6 ft	A13	0.09 lb
W608	Chrome	1/4 in	8 ft	A13	0.10 lb
W606ME	Chrome	6 mm, 1/4 in	2 m, 6 ft	A14	0.09 lb

Executive® Diameter

- Durable metal case
- Compact size for easy storage and transport
- Designed for measuring diameters
- Double-sided blade print - simply turn the blade over for a conversion from diameter to circumference
- Easy-to-read bold graduations



Cat. No.	Case Color	Blade Width	Blade Length	Blade Style	Product Weight
W606P	Chrome	1/4 in	6 ft	A15	0.09 lb
W606PD	Chrome	1/4 in	6 ft	A16	0.08 lb
W606PM	Chrome	6 mm, 1/4 in	2 m, 6.5 ft	A17	0.09 kg

Architect's Pocket Scale

- Yellow clad blade
- 1/4"/6mm yellow steel blade has jet black markings
- Automatic blade return



Cat. No.	Case Color	Blade Width	Blade Length	Blade Style	Product Weight
W393	Chrome	1/4 in	5 ft	A18	0.20 lb

Professional Measuring Wheels

- Gear-based counter drive is more accurate and durable than the traditional belt drive
- Bolstered folding joint allows for compact storage and longer product life
- Glare-resistant counter display is easy to read
- Overmold pistol grip handle for increased user comfort
- Aggressive treaded wheel for improved traction
- Built in kickstand supports wheel for simple measurement recording



Cat. No.	Ext. Length	Folded Length	Wheel Diameter	Graduation	Maximum Distance	Product Weight
PSMW48N	23.6 in	23 in	12 in	Feet and Inches	9999 Ft	2.915 lb
PSMW48NM	23.6 in	23 in	12 in	Meters	9999 m	2.915 lb

Professional Centerline Measuring Wheels

- Centerline wheel for increased balance and more accurate measurements
- Gear-based counter drive is more accurate and durable than the traditional belt drive
- Bolstered folding joint allows for compact storage and longer product life
- Heavy-duty wheel wiper prevents debris buildup
- Glare-resistant counter display is easy to read
- Analog counter dial resets at 10,000 ft.
- Ergonomic dual material pistol grip handle
- Built in kickstand supports wheel for simple measurement recording



Cat. No.	Folded Length	Ext. Length	Wheel Diameter	Graduation	Maximum Distance	Product Weight
PSMW18N	24 in	20.7 in	4 in	Feet and Inches	9999 Ft	1.240 lb
PSMW48CL	20 in	38.5 in	12 in	Feet and Inches	9999 Ft	4.01

Compact Measuring Wheel

- Dual wheel design for increased balance and more accurate measurements
- Gear-based counter drive is more accurate and durable than the traditional belt drive
- Telescoping handle allows for compact storage
- Glare-resistant counter display is easy to read
- Analog counter dial resets at 10,000 ft.
- Overmold pistol grip handle for increased user comfort
- Built in kickstand supports wheel for simple measurement recording



Cat. No.	Folded Length	Ext. Length	Wheel Diameter	Graduation	Maximum Distance	Product Weight
PSMW28CL	19.5 in	43 in	4 in	Feet and Inches	9999 Ft	1.32

Speedwinder®

- Impact-resistant, self-standing case
- Extends and rewinds in less time than conventional long steel tapes
- Heavy-duty yellow clad blade protected by an abrasion resistant coating
- Easy-to-read bold black markings



Cat. No.	Case Color	Blade Width	Blade Length	Blade Style	Product Weight
HYT50	Rawhide Orange	3/8 in	50 ft	B1	0.85 lb
HYT100	Rawhide Orange	3/8 in	100 ft	B1	1.50 lb
HYT100D	Rawhide Orange	3/8 in	100 ft	B5	1.50 lb
HYT15CME	Rawhide Orange	10 mm, 3/8 in	15 m, 50 ft	B14	0.90 lb
HYT30CME	Rawhide Orange	10 mm, 3/8 in	30 m, 100 ft	B14	1.20 lb
HYT50CME	Rawhide Orange	10 mm, 3/8 in	50 m, 164 ft	B14	1.50 lb

Pro Series Fiberglass Tapes

- Three interchangeable end hooks for user convenience
- Ring end hook snaps onto stake for one-person measurements
- Standard folding end hook for general measuring needs
- Appraiser's hook attaches to oversized objects such as downspouts
- 3-to-1 rewind for fast blade retraction
- 3/4" blade is more durable; large numbers are easy to read
- 2-sided blade, feet and inches on top, metric on the bottom
- 62 fiberglass strands and double-PVC coating for durability and strength
- Cushion grips on handle and frame arms for comfort



Cat. No.	Case Color	Blade Width	Blade Length	Blade Style	Product Weight
PSFE100	Rawhide Orange	3/4 in	100 ft	C11	2.55 lb
PSFE200	Rawhide Orange	3/4 in	200 ft	C11	3.79 lb
PSFE300	Rawhide Orange	3/4 in	300 ft	C11	4.77 lb
PSFM030CME	Rawhide Orange	19 mm, 3/4 in	30 m, 100 ft	C12	2.2 kg
PSFM060CME	Rawhide Orange	19 mm, 3/4 in	60 m, 200 ft	C12	1.72 kg
PSFM100CME	Rawhide Orange	19 mm, 3/4 in	100 m, 328 ft	C12	1.15 kg

Fiberglass Tapes

- Open four-arm frame design protects the blade and does not trap dirt in the case
- Lightweight case for easy handling and transport
- Dual-material grip elevated above the reel prevents contact between reel and knuckles
- Versatile folding end hook for use in multiple applications
- Rewind reel tucks away for protection during storage



Cat. No.	Case Color	Blade Width	Blade Length	Blade Style	Product Weight
FE050D	Rawhide Orange	1/2 in	50 ft	C2	1.38 lb
FE050	Rawhide Orange	1/2 in	50 ft	C1	1.38 lb
FE100	Rawhide Orange	1/2 in	100 ft	C1	1.65 lb
FE100D	Rawhide Orange	1/2 in	100 ft	C2	1.65 lb
FE150	Rawhide Orange	1/2 in	150 ft	C1	1.82 lb
FE150D	Rawhide Orange	1/2 in	150 ft	C2	1.82 lb
FE200	Rawhide Orange	1/2 in	200 ft	C1	2.00 lb
FE200D	Rawhide Orange	1/2 in	200 ft	C2	2.00 lb
FE300	Rawhide Orange	1/2 in	300 ft	C1	2.80 lb
FE300D	Rawhide Orange	1/2 in	300 ft	C2	3.00 lb
FM015CME	Rawhide Orange	13 mm, 1/2 in	15 m, 50 ft	C4	1.30 lb
FM030CME	Rawhide Orange	13 mm, 1/2 in	30 m, 100 ft	C4	1.47 kg
FM030DM	Rawhide Orange	13 mm, 1/2 in	30 m, 100 ft	C7	1.58 lb
FM030CM	Rawhide Orange	13 mm, 1/2 in	30 m, 100 ft	C3	1.56 lb
FM050CME	Rawhide Orange	13 mm, 1/2 in	50 m, 164 ft	C4	1.75 lb
FM050CM	Rawhide Orange	13 mm, 1/2 in	50 m, 164 ft	C3	1.75 lb
FM060CME	Rawhide Orange	13 mm, 1/2 in	60 m, 200 ft	C4	0.91 kg
FM100CME	Rawhide Orange	13 mm, 1/2 in	100 m, 328 ft	C4	0.72 kg

Pro Series Ny-Clad® Steel Tapes

- Fast 3-to-1 blade retraction saves time in the field
- Durable nylon coating on blade resists wear under extreme conditions
- Steel blade will not stretch under normal use



Cat. No.	Case Color	Blade Width	Blade Length	Blade Style	Product Weight
PS1806N	Chrome Clad® blade	1/2 in	100 ft	E4	2.02 lb
PS1806DN	Chrome Clad® blade	1/2 in	100 ft	E5	1.98 lb
PS1808N	Chrome Clad® blade	1/2 in	200 ft	E4	3.04 lb
PS1808DN	Chrome Clad® blade	1/2 in	200 ft	E5	3.14 lb
PS1809DN	Chrome Clad® blade	1/2 in	300 ft	E5	4.11 lb

Linear

- Lightweight high impact ABS winding drum for smooth tape recovery
- Non-conductive easy-to-read black and red markings on a yellow background
- Durable 1/2"-wide fiberglass tape with protective coating



Cat. No.	Case Color	Blade Width	Blade Length	Blade Style	Product Weight
T703	Rawhide Orange	1/2 in	50 ft	C1	0.90 lb
703D	Rawhide Orange	1/2 in	50 ft	C2	0.80 lb
706L	Rawhide Orange	1/2 in	100 ft	C1	1.20 lb
706D	Rawhide Orange	1/2 in	100 ft	C2	1.30 lb

Closed Reel Steel Long Tape

- 3:1 gear ratio for fast winding
- Dual material case for added durability; overmold surround allows for better grip with either hand
- Handle tucks away for convenient storage and transport; won't snag and break
- Dual-sided printed blade with nylon coating for product longevity and versatility – top side SAE, bottom side metric
- End hook clips into housing to prevent it from catching on items while in storage



Cat. No.	Case Color	Blade Width	Blade Length	Blade Style	Product Weight
ST100	Gray/Rawhide Orange	3/8 in, 9.5 mm	30 m, 100 ft	C4	1.100 lb

Hi Line® Tapes

- Rugged, vinyl-covered steel case
- Synthetic fiber blade is non-conductive
- Ring attached on end



Cat. No.	Case Color	Blade Width	Blade Length	Blade Style	Product Weight
HD403N	Black	5/8 in	50 ft	C5	1.00 lb
HD403DN	Black	5/8 in	50 ft	C6	1.00 lb
HD406N	Black	5/8 in	100 ft	C5	1.40 lb
HDH406N	Black	5/8 in	100 ft	C5	1.40 lb
HDH406DN	Black	5/8 in	100 ft	C6	1.40 lb
HD406DN	Black	5/8 in	100 ft	C6	1.40 lb

Anchor®

- Rugged, vinyl-covered steel case
- Large easy-action winding drum and friction washers
- Nylon roller guides the tape smoothly in and out of case
- Chrome Clad® blade



Cat. No.	Case Color	Blade Width	Blade Length	Blade Style	Product Weight
C213CN	Brown	3/8 in	50 ft	B3	0.93 lb
C213CXN	Brown	3/8 in	50 ft	B4	1.00 lb
C213DN	Brown	3/8 in	50 ft	B5	0.90 lb
TC213N	Brown	3/8 in	50 ft	B7	1.00 lb
C21616THBLKN	Brown	3/8 in	100 ft	B2	1.60 lb
C216DN	Brown	3/8 in	100 ft	B5	1.55 lb

Leader®

- Rugged, vinyl-covered steel case
- Large easy action winding drum and friction washers
- Nylon roller guides the tape smoothly in and out of case
- Chrome Clad® blade
- Folding end hook ring



Cat. No.	Case Color	Blade Width	Blade Length	Blade Style	Product Weight
HC253N	Black	3/8 in	50 ft	B7	1.00 lb
HC256N	Black	3/8 in	100 ft	B7	1.70 lb

Challenge™

- Rugged, vinyl-covered steel case
- Easy action winding drum and friction washers
- Nylon rollers guide the tape smoothly in and out of case
- Chrome Clad® blade



Cat. No.	Case Color	Blade Width	Blade Length	Blade Style	Product Weight
261PTHN	Brown	3/8 in	33 ft	B11	0.70 lb
263PN	Brown	3/8 in	50 ft	B11	0.80 lb
263PCALN	Brown	3/8 in	50 ft	B11	0.80 lb

Artisan® Diameter and Tree Tapes

- Rugged, vinyl-covered steel case
- Chrome Clad® and Nubian® blade
- Ergonomic easy-winding drum with nylon rollers to guide the tape smoothly in and out of case



Cat. No.	Case Color	Blade Width	Blade Length	Blade Style	Product Weight
120TPN	Brown	3/8 in	20 ft	B10	0.610 lb
C120TPN	Brown	3/8 in	20 ft	B10	0.550 lb
120PN	Brown	3/8 in	20 ft	B12	0.470 lb
C106PMN	Brown	10 mm, 3/8 in	6.5 m, 21 ft	B15	0.505 lb
C106TPMN	Brown	10 mm, 3/8 in	6.5 m, 21 ft	B15	0.550 lb

Banner™

- Rugged, vinyl-covered steel case
- Large easy action winding drum and friction washers
- Nylon rollers guide the tape smoothly in and out of case
- Yellow clad tape; 3/8"/10mm wide and .008"/0.2mm thick
- Bold graduations with black and red numbers for accurate measuring
- Folding end hook ring



Cat. No.	Case Color	Blade Width	Blade Length	Blade Style	Product Weight
HW223	Brown	3/8 in	50 ft	B1	1.00 lb
HW223D	Brown	3/8 in	50 ft	B5	0.90 lb
HW226	Brown	3/8 in	100 ft	B1	1.60 lb
HW226D	Brown	3/8 in	100 ft	B5	1.60 lb
HW223ME	Brown	10 mm, 3/8 in	15 m, 50 ft	B9	0.90 lb
HW226ME	Brown	10 mm, 3/8 in	30 m, 100 ft	B9	1.60 lb
HW227CME	Brown	10 mm, 3/8 in	50 m, 164 ft	B8	2.50 lb

Home Shop

- Rugged, vinyl-covered steel case
- Large easy action winding drum with friction washers
- Yellow clad blade
- .005" thick blade
- Folding end hook ring



Cat. No.	Case Color	Blade Width	Blade Length	Blade Style	Replacement Blade No.	Product Weight
HW50	Brown	3/8 in	50 ft	B1	OY50	0.70 lb
HW100	Brown	3/8 in	100 ft	B1	OY100	1.25 lb

Peerless

- Designed for engineers and surveyors who prefer a 4-arm reel
- Reel is nickel plated, 4-arm, with rollers in each arm for smooth winding
- Open design construction aids in drying line and clearing out dirt
- Long, easy-action winding handle locks line in any position
- Chrome Clad® and yellow clad blade
- Blade 1/4"/6mm wide and 0.016"/0.4mm thick
- Pair of 580 finger rings and a 579 engineer's conversion rule are furnished with tape or replacement line
- Reel available separately



Cat. No.	Arms	Blade Width	Blade Length	Blade Style	Replacement Blade No.	Product Weight
C1276N	4	1/4 in	100 ft	E3	OC1276	2.40 lb
C1276DN	4	1/4 in	100 ft	E1	OC1276D	2.40 lb
Y1276DN	4	1/4 in	100 ft	E1	RY1276D	2.10 lb
C1278N	4	1/4 in	200 ft	E3	OC1278	3.70 lb
C1278DN	4	1/4 in	200 ft	E1	OC1278D	3.70 lb
C2730MMEN	4	6 mm, 1/4 in	30 m, 100 ft	E13	OC2730MME	2.40 lb
C2750DMMN	4	6 mm, 1/4 in	50 m, 164 ft	E12	OC2750DMM	3.44 lb
C2750MMEN	4	6 mm, 1/4 in	50 m, 164 ft	E13	None	3.36 lb
C2750MMECALN	4	6 mm, 1/4 in	50 m, 164 ft	E13	None	3.36 lb
C2730MMN	4	6 mm, 1/4 in	30 m, 100 ft	E11	OC2730MM	2.40 lb

Derrick

- Extra large winding drum provides rapid line recovery
- Chrome Clad® blade
- Nominal blade thickness 0.019"
- Special hook ring with ribbed face at zero
- Leather tether strap is provided to use through eye at base of handle



Cat. No.	Blade Width	Blade Length	Blade Style	Replacement Blade No.	Product Weight
C2276DN	1/4 in	100 ft	E1	OC2276D	2.90 lb
CD2750MMEN	6 mm, 1/4 in	50 m, 164 ft	E13	OCD2750MME	3.60 lb
CD2730DMMN	6 mm, 1/4 in	30 m, 100 ft	E12	OCD2730DMM	2.75 lb
C2276MEN	6 mm, 1/4 in	30 m, 100 ft	E2	OC2276ME	3.00 lb

Western®

- Reel is nickel-plated, 4-arm, with rollers in each arm for smooth winding
- Oversize drum with long, one-piece winding handle for fast line recovery
- Turning handle locks line at any position
- Riveted clips for holding thongs
- Blank space at each end
- Reel available separately



Cat. No.	Arms	Blade Width	Blade Length	Blade Style	Replacement Blade No.	Product Weight
C1676DN	4	1/4 in	100 ft	E1	OC1676D	3.00 lb

Chrome Clad®

- Reel is nickel plated, 4-arm, with rollers in each arm for smooth winding
- Long, easy-action winding handle locks line in any position
- 3/8"/10mm wide and 0.008" thick
- Reel available separately



Cat. No.	Arms	Blade Width	Blade Length	Blade Style	Replacement Blade No.	Product Weight
C1286DN	4	3/8 in	100 ft	E1	OC1286D	2.20 lb
C1286N	4	3/8 in	100 ft	E3	None	2.20 lb
C1288BLKN	4	3/8 in	200 ft	E3	None	3.19 lb



Innovation that Delivers: Introducing the Ex6

An original in its category, Crescent's Ex6 layout square delivers 2-in-1 capabilities, making woodworking and framing simpler. The Ex6 eliminates the need to carry a 7-in and 12-in square and acts as a continuous edge for scribing and marking large scale lumber.

Laser-etched markings add another level of efficiency, increasing visibility and significantly reducing signs of wear and tear. When you've finished a task, the tool conveniently folds to fit comfortably in a pocket or work pouch. A practical locking mechanism holds the foldout extension securely for transport. With all the elements of a standard layout square and high-performing additions, the Ex6 is sure to be an essential tool that trades professionals take wherever they go.

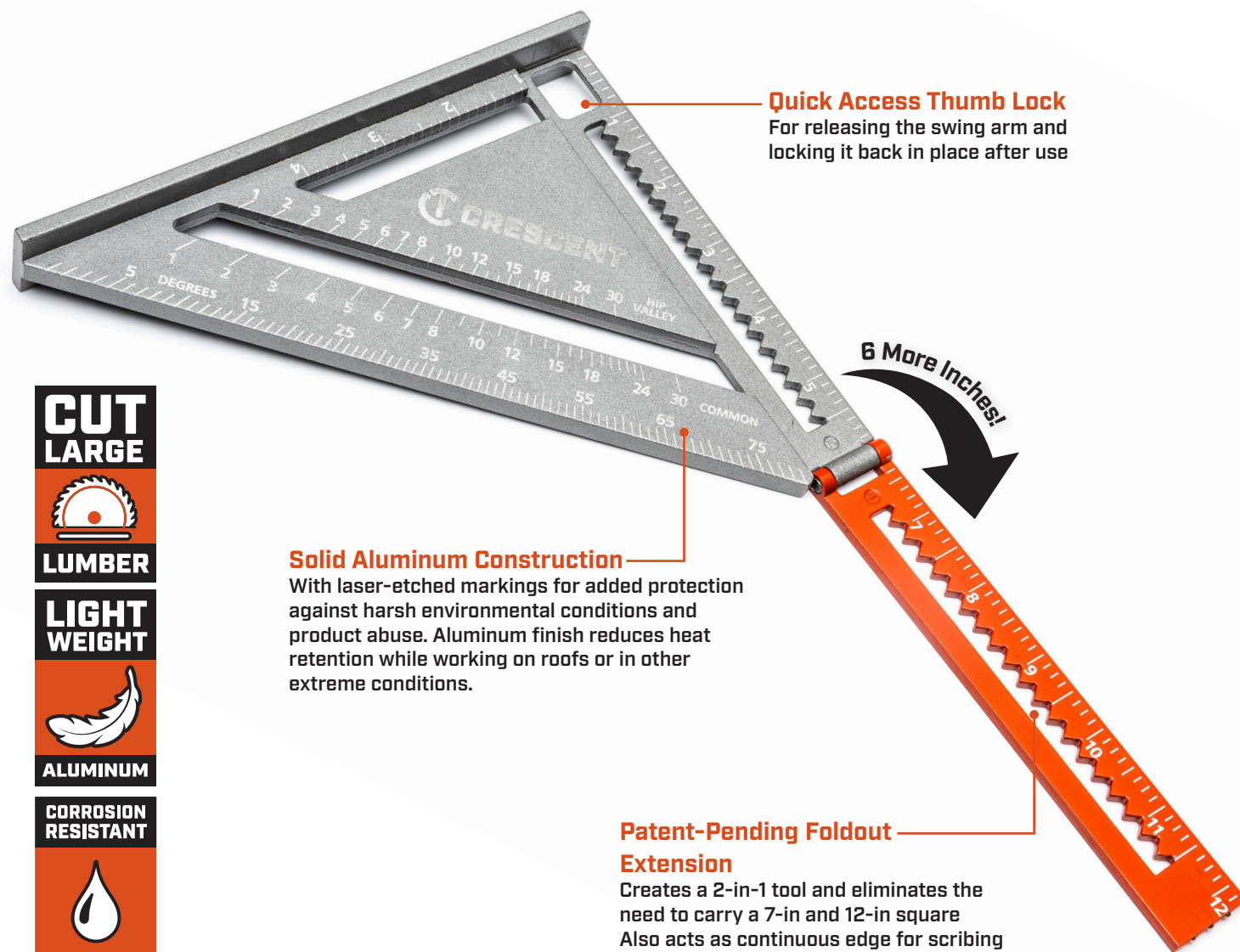

Quick Access Thumb Lock
For releasing the swing arm and locking it back in place after use

Solid Aluminum Construction
With laser-etched markings for added protection against harsh environmental conditions and product abuse. Aluminum finish reduces heat retention while working on roofs or in other extreme conditions.

Patent-Pending Foldout Extension
Creates a 2-in-1 tool and eliminates the need to carry a 7-in and 12-in square
Also acts as continuous edge for scribing and marking large scale lumber

- CUT LARGE**
- 
- LUMBER**
- LIGHT WEIGHT**
- 
- ALUMINUM**
- CORROSION RESISTANT**
- 
- FINISH**

Drywall Square

- Commonly used to mark and cut drywall, plywood and plasterboard
- Bolstered joint between the blade and head for prolonged accuracy and durability
- Lightweight aluminum construction
- High contrast numbers for increased legibility
- Corrosion resistant finish



Cat. No.	Graduation	Blade Width	Blade Length	Product Weight
L48DS	1/8 in	22 in	49.5 in	2.380 lb

2-in-1 Extendable Layout Tool

- 6-inch fold-out extension arm eliminates the need for carrying both a 7-inch and 12-inch square
- Quick access thumb lock releases the fold-out extension and locks it back into place after use
- Solid aluminum construction and corrosion resistant finish for durability
- Laser-etched markings for visibility and durability
- Lightweight and easy to store in your work pouch or pocket



Cat. No.	Graduation	Folded Length	Ext. Length	Overall Width	Overall Height	Product Weight
LSSP6-07	1/16 in	6.5 in	12.52 in	7.25 in	1.2 in	0.730 lb

Combination Squares

- Extruded square head with integrated level for increased drop durability and accuracy
- Knurled nut easily adjusts ruler to align measurements
- Laser etched numbers increase legibility and protect against wear
- Markings in inches and centimeters
- Brass scribe stores in handle for quick and easy marking



Cat. No.	Graduation	Blade Thickness	Blade Width	Blade Length	Product Weight
L06CS	1/32 in & 0.1cm	1/2 in	3-3/8 in	6 in	0.240 lb
L12CS	1/32 in & 0.1cm	3/4 in	4-3/4 in	12 in	0.670 lb

Framing and Carpenter Squares

- Steel construction with high contrast numbers for increased legibility
- Dual-sided print with increments from inches to 1/16th
- Protective coating to maintain print legibility
- Corrosion resistant finish

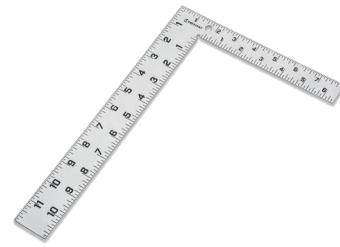

Cat. No.	Type	Material	Graduation	Blade Thickness	Blade Width	Blade Length	Product Weight
L0812US	Carpenter	Steel	1/16 in	3/32 in	8 in	12 in	0.650 lb
L1624CS	Carpenter	Steel	1/16 in	3/32 in	16 in	24 in	1.650 lb
L1624RS	Framing	Aluminum	1/16 in	3/32 in	16 in	24 in	0.780 lb

Aluminum Yardstick

- Lightweight, flexible, rustproof, and sharply defined yardstick
- Lies flat and has a hang-up hole for storage
- Easy-to-read markings on straight parallel edges
- Fine graduations one side only, both edges in inches to 1/16ths
- Hole in one end for hanging



Cat. No.	Graduation	Blade Thickness	Blade Width	Blade Length	Product Weight
T1260N	1/16 in	1/32 in	15/64 in	36 in	0.30 lb

Metric English Aluminum Meter Stick

- Useful for making the transition to the metric system
- Graduated on front side in inches to 1/16ths on upper edge
- Graduated decimeters, centimeters and millimeters lower edge
- Reverse side shows table of equivalents and conversions
- 1" x 1m aluminum rule
- Hole in one end for hanging



Cat. No.	Graduation	Blade Thickness	Blade Width	Blade Length	Product Weight
1261MEN	1/16 in	1/32 in	27 mm, 1 in	1 m, 3 ft	0.40 lb

One-Piece Steel Rules

- Markings are heavier than on machine-divided rules
- Bold, permanent markings are deeply etched and black-filled
- Large graduations marked on both sides and both edges
- Upper edge graduated in 1/8ths, lower edge in 1/16ths
- Opposite sides measure from opposite ends
- Hole in one end for hanging

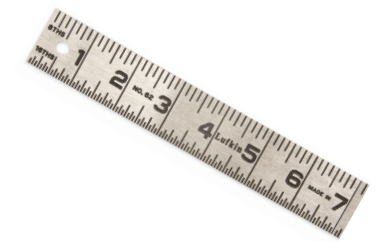

Cat. No.	Graduation	Blade Thickness	Blade Width	Blade Length	Product Weight
621FTN	1/8 in & 1/16 in	1/16 in	1-1/4 in	1 ft	0.30 lb
622FTN	1/8 in & 1/16 in	1/16 in	1-1/4 in	2 ft	0.50 lb
623FTN	1/8 in & 1/16 in	1/16 in	1-1/4 in	3 ft	0.80 lb
624FTN	1/8 in & 1/16 in	1/16 in	1-1/4 in	4 ft	1.00 lb
626FTN	1/8 in & 1/16 in	1/16 in	1-1/4 in	6 ft	1.50 lb

School Shop Steel Rule

- Used in school shops and industrial plants
- Medium weight tempered steel rule
- Deeply-etched permanent markings are black-filled for easy reading
- Large graduations, marked upper edge both sides
- One side 1/8ths; other side 1/16ths
- Opposite sides measure from opposite ends
- Hole in one end for hanging



Cat. No.	Graduation	Blade Thickness	Blade Width	Blade Length	Product Weight
6012INN	1/8 in & 1/16 in	1/32 in	3/4 in	12 in	0.07 lb

Tinner's Steel Circumference Rules

- Standard rule for tanners and other sheetmetal workers
- Tempered medium-weight steel
- Black markings for easy reading
- One side upper edge marked inches to 1/16ths
- Reverse side has formulas for calculating circumference, diameter, area
- Hole in one end for hanging

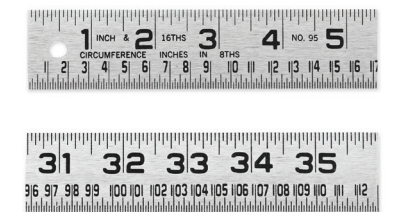

Cat. No.	Graduation	Blade Thickness	Blade Width	Blade Length	Product Weight
953FTN	1/8 in & 1/16 in	1/16 in	1-1/4 in	3 ft	0.80 lb
954FTN	1/8 in & 1/16 in	1/16 in	1-1/4 in	4 ft	1.00 lb

Steel Blacksmith's Rule

- Used for converting diameters directly to circumference measurements
- Built-in catch brings rule to a firm stop when opened straight
- Legible, permanent, deeply etched black markings
- Lower edge graduated to 1/16ths of an inch, upper edge to 1/8ths



Cat. No.	Graduation	Blade Width	Blade Length	Product Weight
86N	1/8 in & 1/16 in	3/4 in	2 ft	0.14 lb

Doyle Log Scale

- Designed for estimating board feet in a cut log
- Graduated inches to 1/16ths lower edge
- Outside markings for 10' and 18' logs
- Inside markings for 12', 14' and 16' logs

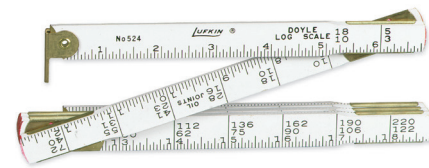

Cat. No.	Graduation	Blade Width	Blade Length	Product Weight
TT524N	1/16 in	5/8 in	4 ft	0.24 lb

Red End® Brick Mason's Folding Wood Rule

- For use in brick laying applications
- Durable construction with brass plated joints and brass end caps that prevent the ends from splintering
- Featuring brick spacing rule on the inside surface
- Outside markings are graduated from feet and inches to 1/16th along both top and bottom edges
- 6 ft. length and 5/8 in. width

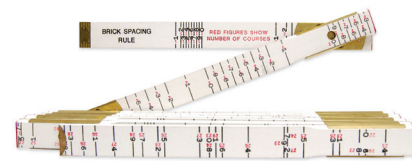

Cat. No.	Graduation	Blade Width	Blade Length	Product Weight
T636N	1/16 in	5/8 in	6 ft	0.30 lb

Red End® Oversized Brick Mason's Folding Wood Rule

- Used by bricklayers for oversized brick
- Graduated vertical markings go from inches to 16ths along both edges
- Brick mason scale on inside, red course counters numbered consecutively
- Regular outside markings in black
- 6 Foot Length

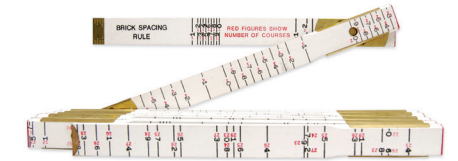

Cat. No.	Graduation	Blade Width	Blade Length	Product Weight
T656N	1/16 in	5/8 in	6 ft	0.35 lb

Red End® Engineer's Folding Wood Rules

- Joints are brass-plated for durability; brass end caps prevent ends from splitting
- Red foot figures for clear visibility and identification
- Graduated in feet, tenths of feet, and hundredths of feet
- Regular outside markings in feet, inches and 1/16ths

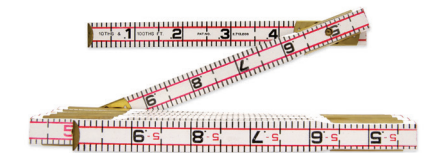

Cat. No.	Graduation	Blade Width	Blade Length	Product Weight
1066DMN	1/16 in	16 mm, 5/8 in	2 m, 6 ft	0.36 lb
1066DN	1/16 in	5/8 in	6 ft	0.35 lb

Red End® Extension Folding Wood Rules

- Graduated slide rule extends up to 6 additional inches
- Stops at each end to prevent slide from falling out
- Marked along both sides and both edges
- Graduated to 1/16ths of an inch

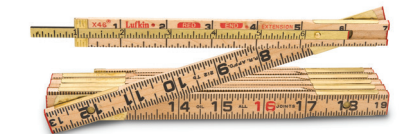

Cat. No.	Graduation	Blade Width	Blade Length	Product Weight
TX46N	1/16 in	5/8 in	6 ft	0.35 lb
HX46N	1/16 in	5/8 in	6 ft	0.39 lb
X48N	1/16 in	5/8 in	8 ft	0.50 lb
X46FN	1/16 in	5/8 in	6 ft	0.35 lb

Red End® Folding Wood Rules

- Durable construction with brass-plated joints and brass end caps which prevent the ends from splitting
- Embossed numbers and graduations prevent print corrosion
- Marked on both sides for versatile use

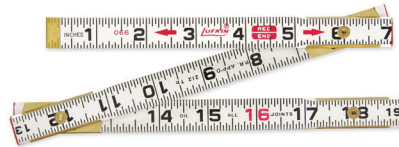

Cat. No.	Blade Width	Blade Length	Product Weight
T066N	5/8 in	6 ft	0.34 lb
O66FN	5/8 in	6 ft	0.34 lb
O62CMEN	5/8 in	2 m, 6 ft	0.39 lb

Red End® Modular Spacing Folding Wood Rule

- Durable construction with brass-plated joints and brass end caps which prevent the ends from splitting
- Outside is graduated along both edges to 1/16ths of an inch
- Inside marked with 6 scales in 16" modules



Cat. No.	Graduation	Blade Width	Blade Length	Product Weight
646LN	1/16 in	5/8 in	6 ft	0.35 lb

Red End® Two Way Folding Wood Rule

- Flat inside markings lie close to the work
- For measuring left to right and right to left
- Marked on both sides for versatile use
- Graduations in feet, inches and 1/16ths on both edges of both sides

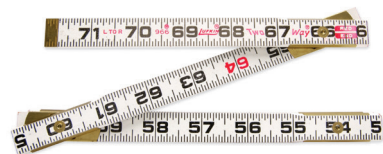

Cat. No.	Graduation	Blade Width	Blade Length	Product Weight
966N	1/16 in	5/8 in	6 ft	0.34 lb

A Perfect Snap Every Time.

The new Crescent Lufkin line of chalk reels offers the professional tradesperson the ultimate in ease of use and dependability. Add to that our offering of genuine Crescent Lufkin chalk — including our new ultra high-visibility Hard Mark Blue — and you have an unbeatable chalk reel and chalk performance combination.

- FASTER**
6X
REWIND
- NESTED**
END HOOK
- ROTATING**
HUBLOCK
- ENHANCED**
3X
GRIP
ENDHOOK



Hard Mark Blue Chalk

Quality chalk designed to be a brighter blue for increased line visibility, regardless of the light conditions or surface.

CB25BA, CB08BA

Professional Aluminum Chalk & Reels

- 6:1 gear ratio, fold-away, rotating hub for faster rewind and reel protection during storage
- Single hand hub lock allows user to stop line in place and snap lines with only one hand
- Nesting end hook retracts into a nested position, protecting the hook from unwanted snags
- Reinforced string perfectly braided for the best balance between chalk retention and reduced overspray
- One-way chalk refill valve designed for quick refills without the mess
- Quarter-turn release for secondary access to the chalk box



Cat. No.	Chalk Color	Line Material	Line Length	Case Material	Rewind Ratio	Product Weight
CLA100	Not Included	Braided String	100 ft	Aluminum	6:1	0.074 lb
CLA100B	Blue	Braided String	100 ft	Aluminum	6:1	0.099 lb
CLA100R	Red	Braided String	100 ft	Aluminum	6:1	0.099 lb

Aluminum Chalk & Reels

- Sliding door for quick and easy chalk refilling
- Cast aluminum body for increased durability
- Centerline marker for use as a plumb bob
- Built-in storage dock protects end hook when not in use



Cat. No.	Chalk Color	Line Material	Line Length	Case Material	Rewind Ratio	Product Weight
CLA100A	Not Included	Braided String	100 ft	Aluminum	1:1	0.400 lb
CLA100AB	Blue	Braided String	100 ft	Aluminum	1:1	0.650 lb

Compact Chalk & Reel

- Fold-away handle locks the retrieval arm in place to prevent breaking or inadvertent unreeling
- Release button disengages crank so line can be pulled out faster
- End hook storage on reverse side of reel protects end hook and prevents line tangles during storage
- Reinforced string perfectly braided for the best balance between chalk retention and reduced overspray
- Easy fill side refill door with large opening capacity for quick and effortless refills



Cat. No.	Chalk Color	Line Material	Line Length	Case Material	Rewind Ratio	Product Weight
CL50	Blue	Braided String	50 ft	Plastic	3:1	0.052 lb

Construction Chalk & Reel

- 6:1 gear ratio, fold-away, rotating hub for faster rewind and reel protection during storage
- End hook storage on the backside that protects the end hook and prevents tangles
- Combo hook and ring end hook for use in all construction environments
- Reinforced string perfectly braided for the best balance between chalk retention and reduced overspray
- One-way chalk refill valve designed for quick chalk refills without the mess



Cat. No.	Chalk Color	Line Material	Line Length	Case Material	Rewind Ratio	Product Weight
CL150	Not Included	Braided String	150 ft	Plastic	6:1	0.033 lb

Contractor Chalk & Reels

- 6:1 gear ratio, fold-away, rotating hub for faster rewind and reel protection during storage
- Single hand hub lock allows user to stop line in place and snap lines with only one hand
- Nesting end hook retracts into a nested position, protecting the hook from unwanted snags
- Reinforced string perfectly braided for the best balance between chalk retention and reduced overspray
- One-way chalk refill valve designed for quick refills without the mess
- Quarter-turn release for secondary access to the chalk box



Cat. No.	Chalk Color	Line Material	Line Length	Case Material	Rewind Ratio	Product Weight
CL0100	Not Included	Braided String	100 ft	Plastic	6:1	0.050 lb
CL100B	Blue	Braided String	100 ft	Plastic	6:1	0.074 lb
CL100R	Red	Braided String	100 ft	Plastic	6:1	0.074 lb

Chalk & Reels

- 3:1 gear crank ratio for faster rewind
- Sliding door for quick and easy chalk refilling
- Centerline marker for use as a plumb bob
- Built-in storage dock protects end hook when not in use
- Release button disengages crank so line can be pulled out faster



Cat. No.	Chalk Color	Line Material	Line Length	Case Material	Rewind Ratio	Product Weight
CLP100	Not Included	Braided String	100 ft	Plastic	3:1	0.308 lb
CLP100B	Blue	Braided String	100 ft	Plastic	3:1	0.558 lb
CLP100R	Red	Braided String	100 ft	Plastic	3:1	0.558 lb

HardMark Blue Chalk Refill

- HardMark Blue is a Crescent Lufkin proprietary marking chalk designed to be a brighter blue for increased line visibility regardless of the light condition or surface
- High visibility blue chalk designed to be three times more visible than standard chalks
- Unique bottle geometry prevents the bottle from rolling on sloped surfaces
- Easy fill bottle top design allows chalk to flow faster for quick refills



Cat. No.	Chalk Color	Chalk Volume	Product Weight
CB08BA	HardMark Blue	8 oz	0.572 lb
CB25BA	HardMark Blue	2.5 lbs	2.750 lb

8 oz Chalk Refill

- Marking chalk for use with chalk reels
- Unique bottle geometry prevents the bottle from rolling on sloped surfaces
- Easy fill bottle top design allows chalk to flow faster for quick refills



Cat. No.	Chalk Color	Chalk Volume	Product Weight
CB08B	Blue	8 oz	0.572 lb
CB08BL	Black	8 oz	0.572 lb
CB08R	Red	8 oz	0.572 lb
CB08Y	Yellow	8 oz	0.572 lb

2.5 Lbs Chalk Refill

- Marking chalk for use with chalk reels
- Unique bottle geometry prevents the bottle from rolling on sloped surfaces
- Easy fill bottle top design allows chalk to flow faster for quick refills



Cat. No.	Chalk Color	Chalk Volume	Product Weight
CB25B	Blue	2.5 lbs	2.750 lb
CB25R	Red	2.5 lbs	2.750 lb

Atlas® Chrome Clad® / Nubian® Double Duty

- Heavy-duty frame designed for years of rugged use
- All frames include a grounding strap
- Plumb bob must be ordered separately



Cat. No.	Bob Cut	Blade Width	Blade Length	Blade Style	Product Weight
CN129012SF5N	590	1/2 in	18 ft	D1	1.60 lb
CN1290SF590N	590	1/2 in	25 ft	D1	1.60 lb
CN1291SF590N	590	1/2 in	33 ft	D1	1.90 lb
CN1293SDF590N	590	1/2 in	50 ft	D2	2.20 lb
CN1293SF5871N	5871/2	1/2 in	50 ft	D1	2.30 lb
CN1293SF590N	590	1/2 in	50 ft	D1	2.20 lb
CN1294SF5871N	5871/2	1/2 in	66 ft	D1	2.70 lb
CN1294SF590N	590	1/2 in	66 ft	D1	2.60 lb
CN1295SF590N	590	1/2 in	75 ft	D1	2.90 lb
CN1296SF590N	590	1/2 in	100 ft	D1	3.56 lb
CN1290SMEN	590	13 mm, 1/2 in	8 m, 26 ft	D3	1.80 lb
CN1293SMEF59N	590	13 mm, 1/2 in	15 m, 50 ft	D3	2.30 lb
CN1294SMEF59N	590	13 mm, 1/2 in	20 m, 66 ft	D3	2.60 lb
CN1295SME590N	590	13 mm, 1/2 in	23 m, 75 ft	D3	2.88 lb
CN1295SMEN	5871/2	13 mm, 1/2 in	23 m, 75 ft	D3	2.70 lb
CN1296SMEF59N	590	13 mm, 1/2 in	30 m, 100 ft	D3	3.980 lb
CN1298SME590N	590	13 mm, 1/2 in	38 m, 125 ft	D3	4.20 lb

Atlas® Chrome Clad®

- Heavy-duty frame designed for years of rugged use
- All frames include a grounding strap
- Blade counts graduated feet down to 1/8th inches, for instantaneous foot readings
- Plumb bob must be ordered separately



Cat. No.	Bob Cut	Blade Width	Blade Length	Blade Style	Product Weight
C129012SFN	590	1/2 in	18 ft	D4	1.60 lb
C1290SF590N	590	1/2 in	25 ft	D4	1.80 lb
C1291SF590N	590	1/2 in	33 ft	D4	1.90 lb
C1293SF590N	590	1/2 in	50 ft	D4	2.30 lb
C2910MME590N	590GM	13 mm, 1/2 in	10 m, 33 ft	D6	1.95 lb
C2915MME590N	590GM	13 mm, 1/2 in	15 m, 50 ft	D6	2.35 lb
C2920MME150MN	150 mm	13 mm, 1/2 in	20 m, 66 ft	D6	2.50 lb
C2920MME590N	590GM	13 mm, 1/2 in	20 m, 66 ft	D6	2.70 lb
C2930MME590N	590GME	13 mm, 1/2 in	30 m, 98 ft	D6	3.95 lb

Atlas® Nubian®

- Heavy-duty frame designed for years of rugged use
- All frames include a grounding strap
- Blade protected by flowed-on epoxy coating
- Ideal for gauging clear oils
- Plumb bob must be ordered separately



Cat. No.	Bob Cut	Blade Width	Blade Length	Blade Style	Product Weight
1290SF590N	590	1/2 in	25 ft	D5	1.70 lb
1293SF590N	590	1/2 in	50 ft	D5	2.30 lb
1293SM590N	590	13 mm, 1/2 in	15 m, 49 ft	D7	1.90 lb

Outage Oil Gauging Plumb Bobs

- Square-shaped solid brass bob
- Eye milled from solid brass block (not removable)
- Zero falls inside top of hook eye
- 3/4"/19mm square, 6"/152mm overall length

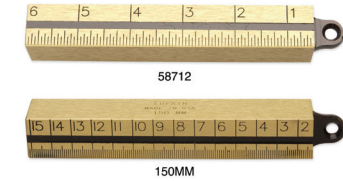

Cat. No.	Weight	Description	SAE/Metric	Measuring Range	Material	Length
58712N	20 oz	Square	SAE/Metric	0 in - 6 in 0mm - 150mm	Brass	6 in
T150MMN	20 oz	Square	Metric	0mm - 150mm	Brass	6 in

Atlas® Stainless Steel®

- Heavy-duty frame designed for years of rugged use
- All frames include a grounding strap
- Designed for use in highly corrosive solutions
- Stainless steel blade resists corrosion
- Plumb bob must be ordered separately
- Recommended plumb bob: S590N



Cat. No.	Bob Cut	Blade Width	Blade Length	Blade Style	Product Weight
S1291F590N	590	1/2 in	33 ft	D4	1.50 lb
S1293F590N	590	1/2 in	50 ft	D4	2.00 lb

Anchor® Replacement Blade

- Anchor® replacement blade for C213DN



Cat. No.	Blade Style	Fits Product Number	Blade Width	Blade Length	Product Weight
OC213DN	B5	C213DN	3/8 in	50 ft	0.60 lb

Artisan® Replacement Blade

- Artisan® replacement blade for 120PN



Cat. No.	Blade Style	Fits Product Number	Blade Width	Blade Length	Product Weight
O120PN	B12	120PN	3/8 in	20 ft	0.30 lb

Inage Oil Gauging Plumb Bobs

- For use in heavy oils
- Cylindrical shaped

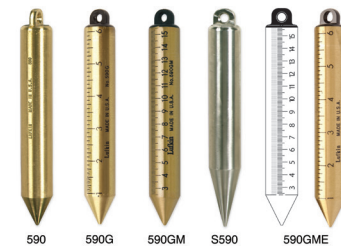

Cat. No.	Weight	Description	SAE/Metric	Measuring Range	Material	Length
590GN	20 oz	Cylindrical, Reads Up	SAE	0 in - 6 in	Brass	6.75 in
590GMN	20 oz	Cylindrical, Reads Up	Metric	0mm - 150mm	Brass	6.75 in
590GMEN	20 oz	Cylindrical, Reads Up	SAE/Metric	0 in - 6 in 0mm - 150mm	Brass	6.75 in
TT590N	20 oz	Cylindrical	No Markings	No Markings	Brass	6.75 in
S590N	20 oz	Cylindrical	No Markings	No Markings	Stainless Steel	6.75 in

Atlas® Stainless Steel Replacement Blades

■ Atlas® replacement blade



Cat. No.	Blade Style	Fits Product Number	Blade Width	Blade Length	Product Weight
OS1291F590N	D4	1291F590N	1/2 in	33 ft	0.70 lb
OS1293F590N	D4	1293F590N	1/2 in	50 ft	0.90 lb

Atlas Nubian® Replacement Blades

■ Atlas Nubian® replacement blade



Cat. No.	Blade Style	Fits Product Number	Blade Width	Blade Length	Product Weight
01290SF590N	D4	1290SF590N	1/2 in	25 ft	0.60 lb
01293SF590N	D4	1293SF590N	1/2 in	50 ft	1.00 lb

Atlas Chrome Clad® / Nubian® Double Duty Replacement Blades

■ Atlas Chrome Clad® / Nubian® Double Duty replacement blade



Cat. No.	Blade Style	Fits Product Number	Blade Width	Blade Length	Product Weight
OC129012SF59N	D4	C129012SFN	1/2 in	18 ft	0.50 lb
OCN129012SF5N	D1	CN129012SF5N	1/2 in	18 ft	0.50 lb
OCN1290SF590N	D1	CN1290SF590N	1/2 in	25 ft	0.60 lb
OCN1291SF590N	D1	CN1291SF590N	1/2 in	33 ft	0.80 lb
OCN1293SF590N	D1	CN1293SF590N	1/2 in	50 ft	1.10 lb
OCN1294SF590N	D1	CN1294SF590N	1/2 in	66 ft	1.50 lb
OCN1295SF590N	D1	CN1295SF590N	1/2 in	75 ft	1.70 lb
OCN1296SF590N	D1	CN1296SF590N	1/2 in	100 ft	2.20 lb
OCN1293SMEF5N	D3	CN1293SMEF5N	13 mm, 1/2 in	15 m, 50 ft	1.20 lb
OCN1294SMEF5N	D3	CN1294SMEF5N	13 mm, 1/2 in	20 m, 66 ft	1.60 lb
OCN1296SMEF5N	D3	CN1296SMEF5N	13 mm, 1/2 in	38 m, 100 ft	2.65 lb

Challenge™ Replacement Blade

■ Challenge™ replacement blade for 261PTH



Cat. No.	Blade Style	Fits Product Number	Blade Width	Blade Length	Product Weight
0261PTHN	B11	261PTHN	3/8 in	33 ft	0.40 lb

Super Hi-Way® Nubian® Replacement Blades

- Nominal thickness 0.017"
- Lines have a blank space at each end
- Extra foot before zero graduated right to left to 1/10ths and 1/100ths
- Balance marked every foot except last foot of each 100' length, 100ths

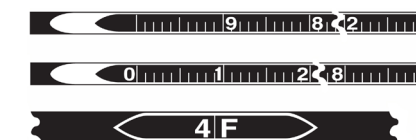

Cat. No.	Fits Product Number	Blade Width	Blade Length	Product Weight
09100BN	Super Hi-Way® Nubian® 5/16" x 100'	5/16 in	100 ft	2.20 lb
09200BN	Super Hi-Way® Nubian® 5/16" x 200'	5/16 in	200 ft	3.60 lb
09300BN	Super Hi-Way® Nubian® 5/16" x 300'	5/16 in	300 ft	5.90 lb

Atlas Chrome Clad® Replacement Blades

■ Atlas Chrome Clad® replacement blade



Cat. No.	Blade Style	Fits Product Number	Blade Width	Blade Length	Product Weight
OC1290SF590N	D4	C1290SF590N	1/2 in	25 ft	0.65 lb
OC1291SF590N	D4	C1291SF590N	1/2 in	33 ft	0.80 lb
OC2910MME590N	D6	C2910MME590N	13 mm, 1/2 in	10 m, 33 ft	0.80 lb

Derrick Replacement Blades

- Derrick replacement blade

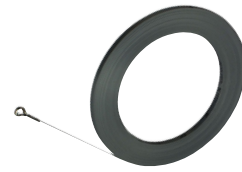

Cat. No.	Blade Style	Fits Product Number	Blade Width	Blade Length	Product Weight
OC2276DN	E1	C2276DN	1/4 in	100 ft	1.60 lb
OC2276MEN	E2	C2276MEN	6 mm, 1/4 in	30 m, 100 ft	0.700

Home Shop Replacement Blades

- Replacement blade



Cat. No.	Blade Style	Fits Product Number	Blade Width	Blade Length	Product Weight
OY50	B1	HW50, 50	3/8 in	50 ft	0.40 lb
OY100	B1	HW100	3/8 in	100 ft	0.80 lb

Western® Replacement Reel

- For 1/4" or 5/16" X 100' lengths of steel tapes only
- Reel is nickel-plated, 2-arm with rollers in each arm for smooth winding
- Oversize drum with long, one-piece winding handle, quick return of line
- 2 arm reel



Cat. No.	Fits Product Number	Blade Width	Blade Length	Style of Case or Reel	Product Weight
T31100N	Fits 100 ft Tapes Only	1/4 in	100 ft	2 Arm	1.40 lb

Engineering and Surveying Replacement Reel

- For 1/2" X 75' Chrome Clad® and gauging tapes
- Reel is nickel-plated, 4-Arm with rollers in each arm for smooth winding
- Oversize drum with long, one-piece winding handle, quick return of line
- 4 arm reel



Cat. No.	Arms	Fits Product Number	Blade Width	Blade Length	Product Weight
9175N	4	Chrome Clad and Gauging Tapes	1/2 in	75 ft	1.30 lb

31 Series Over 100' Length Replacement Reels

- For over 100' lengths
- Chrome 4 arm frame
- Not all replacement parts are sold separately



Cat. No.	Arms	Blade Width	Blade Length	Product Weight
31300N	4	1/4 in	100 ft	3.10 lb
T31200N	4	5/16 in	200 ft	3.00 lb

81 and 91 Series Chrome Clad® and Gauging Tape Replacement Reel

- For 3/8" 10mm and 1/2"/13mm widths - Chrome Clad® and gauging tapes
- Chrome 2 arm frame
- Not all replacement parts are sold separately



Cat. No.	Arms	Blade Width	Blade Length	Product Weight
9150LN	2	1/2 in	50 ft	1.20 lb

Detachable Hook

- Easily attaches and detaches from standard ring tape line
- Heavily nickel plated, zinc hook
- Serrated face grips firmly and releases easily
- On tapes measuring from outer end of ring, zero falls at inside of hook
- Can be used on lines 3/8 inch/10mm or wider



Cat. No.	Product Weight
552N	0.04 lb

Tape Clamps Handle

- Used for quickly gripping a steel tape at any point
- Applies light or heavy tension
- Clamp is applied and removed by simply operating the handle
- Used properly, it will not damage a tape in any way
- Made of chrome-plated zinc alloy



Cat. No.	Product Weight
T584N	0.20 lb

Tape Tension Handle

- Use with steel tapes for extremely accurate measurements
- Rustproof brass construction with black-filled etched graduations
- Graduations begin at snap end, easy-to-read when tension is applied
- Capacity of 30 lb x 1/2 lb and 25kg x 25kg



Cat. No.	Product Weight
586N	0.60 lb

Shaping

Files • Rasps • Sets • Specialty Files



File Terminology

COARSENESS



- Work to be accomplished, roughing or finishing, will determine type of teeth and coarseness for each application
- Most American pattern files are available with 3 grades of cut: bastard-cut, second-cut and smooth-cut
- Swiss pattern files are available in seven cuts: No. 00, 0, 1, 2, 3, 4, and 6
- The degree of coarseness is greater in longer files, but differences between bastard, second and smooth are proportionate

LENGTH

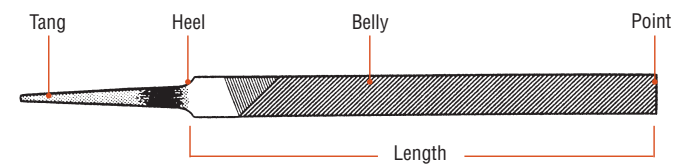

- Length is measured exclusive of tang, from point to heel, unless specified otherwise
- Desired stroke length, type of material and size will determine length required

SHAPE

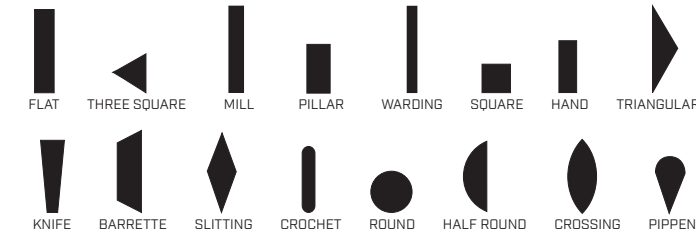

- Area to be filed will determine specific cross-section (round, square, flat, etc.) to be used

Kinds of Teeth

SINGLE-CUT

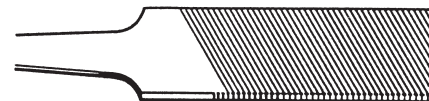

- Single set of parallel, diagonal rows of teeth
- Single-cut files are often used with light pressure to produce a smooth surface finish or to put a keen edge on knives, shears or saws

RASP-CUT

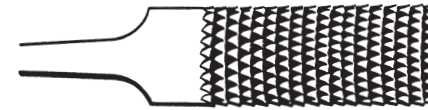

- Series of individual teeth formed by a single-pointed tool
- Produces a rough cut that is used primarily on wood, hooves, aluminum and lead

MAGICUT®



- Single cut teeth divided by angular serrations into shorter cutting edges, which free themselves readily from chips and perform roughing and smoothing at the same time

DOUBLE-CUT



- 2 sets of diagonal rows of teeth
- Second set of teeth cut in opposite diagonal direction and on top of the first set
- First set of teeth is known as the overcut, second is upcut
- Upcut is finer than overcut
- Double-cut file is used with heavier pressure than the single-cut and removes material faster from the workpiece

CURVED-CUT

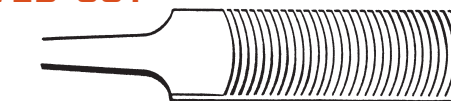

- Teeth arranged in curved contours across the file face
- Curved-cut file is normally used in automotive body shops for smoothing body panels

Fit and Finish in a Single Tool

These American pattern flat files have a bastard cut on one side for aggressive material removal and a smooth cut on the other for more precise finishing. Rough fitting and fine finishing capabilities are combined in a single file to help get jobs done faster.

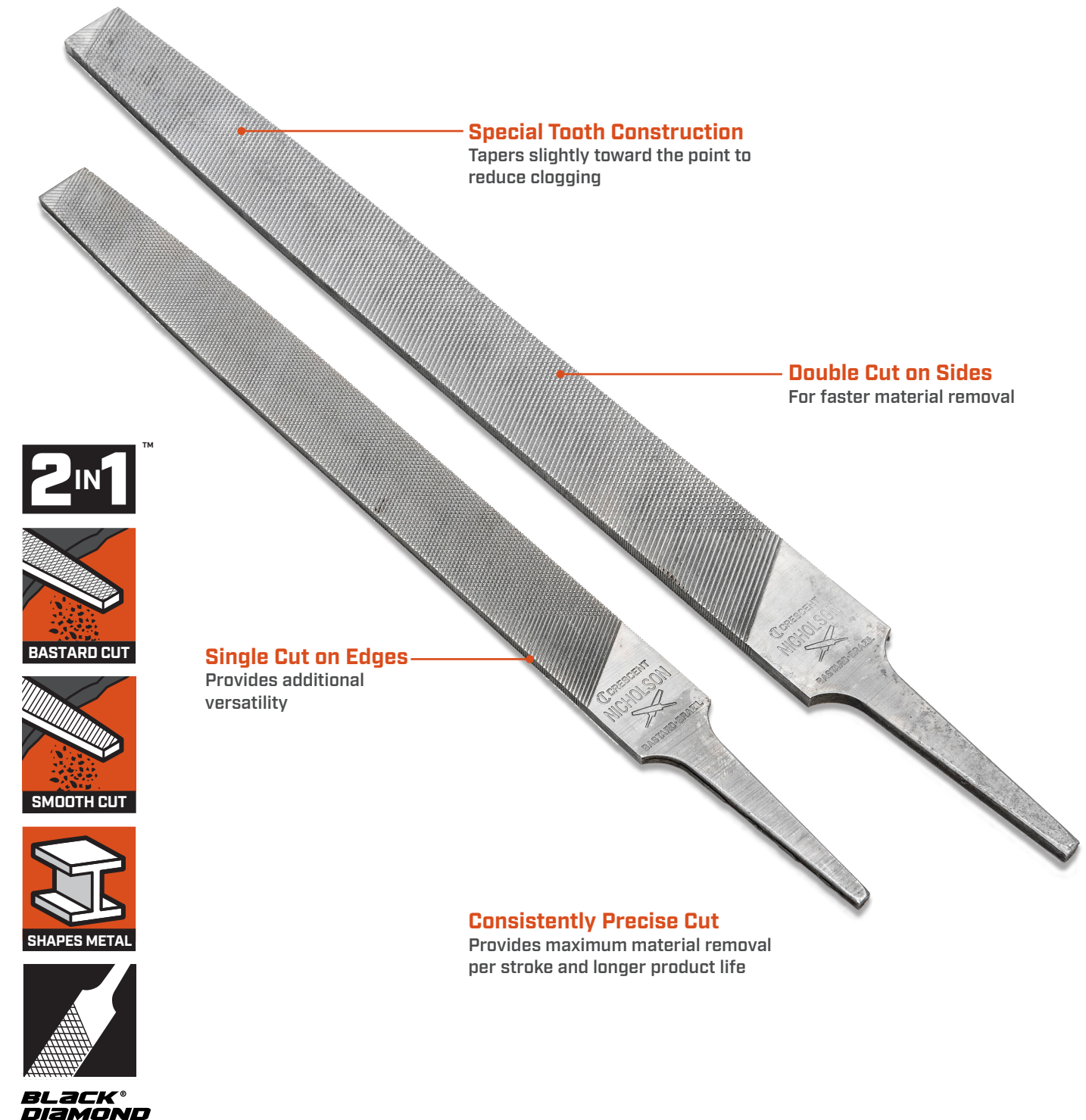

2 IN 1™



2 Pc. 2-in-1 Bastard & Smooth Cut File Set

- American pattern flat file with bastard cut on one side and smooth cut on the other side, providing aggressive material removal and precise finishing capability in one file
- Rectangular cross-section with slight taper towards point
- Double cut on sides and single cut on edges
- Precision engineered to provide maximum material removal per stroke and long product life
- Special tooth construction reduces clogging

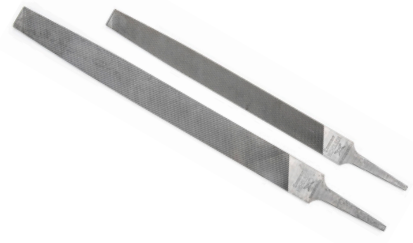

Cat. No.	Included Storage	Product Weight
21981N	None	0.640 lb

Cat. No.	Description
21908N	8" 2-in-1 Bastard and Smooth Cut File
21910N	10" 2-in-1 Bastard and Smooth Cut File

2-in-1 Bastard and Smooth Cut Files

- American pattern flat file with bastard cut on one side and smooth cut on the other, providing aggressive material removal and precise finishing capability in one file
- Rectangular in cross section and tapers slightly towards the point
- Double cut on sides and single cut on edges
- Precision engineered to provide maximum material removal per stroke and long product life
- Special tooth construction reduces clogging



Cat. No.	File Length	Handled	Packaging	Product Weight	Shelf Pack Qty.
21908N	8 in	No	Carded	0.210 lb	6
21910N	10 in	No	Carded	0.430 lb	6

9 Pc. Ergonomic File Set

- Set includes must-have files, which cover a wide range of usage scenarios
- Includes four 10" bastard cut files
- Two 6" tapered files
- Two 8" bastard cut files
- One 12" mill bastard cut file
- Rubber-coated ergonomic handles for better comfort and control
- Includes pouch for storage and organization



Cat. No.	Included Storage	Product Weight
22030HNNN	Pouch	4.35 lb

Cat. No.	Description	Cat. No.	Description
21701HNN	10" Mill Bastard Cut File with Ergonomic Handle	21868HNN	10" Flat Bastard Cut File with Ergonomic Handle
21842HNN	12" Mill Bastard Cut File with Ergonomic Handle	21729HNN	6" Slim Taper File with Ergonomic Handle
-	8" Half Round Bastard Cut File with Ergonomic Handle	-	6" Double Extra Slim Taper File with Ergonomic Handle
-	10" Half Round Bastard Cut File with Ergonomic Handle	-	10" Round Bastard Cut File with Ergonomic Handle
21748HNN	8" Flat Bastard Cut File with Ergonomic Handle		

3 Pc. 6" Ergonomic File Set

- Set includes half round bastard, mill bastard, round bastard files
- Rubber-coated ergonomic handles for better comfort and control
- Bastard coarseness grade for a rough finish
- Basic selection for home and professional use
- Includes pouch for storage and organization



Cat. No.	Included Storage	Product Weight
22015HNNN	Pouch	0.70 lb

Cat. No.	Description
-	6" Half Round Bastard Cut File with Ergonomic Handle
-	6" Round Bastard Cut with Ergonomic Handle
21687HNN	6" Mill Bastard Cut File with Ergonomic Handle

5 Pc. Crescent Nicholson Anniversary Set

- Industrial assortment includes 6-in. slim taper, 8-in. round, 8-in. single-cut mill, 8-in. half-round, and 10-in. double-cut flat files
- Ergonomic co-molded handles with anniversary design provide a comfortable grip, enhancing productivity and reducing hand fatigue
- Tempered steel construction offers strength and durability for long-lasting performance
- Must-have files to cover a broad range of uses
- Includes pouch for storage and organization



Cat. No.	Included Storage	Product Weight
22150HIN	Pouch	1.730 lb

Cat. No.	Description	Cat. No.	Description
21694HNN	8" Mill Bastard Cut File with Ergonomic Handle	-	8" Half Round Bastard Cut File with Ergonomic Handle
21729HNN	6" Slim Taper File with Ergonomic Handle	-	8" Round Bastard Cut File with Ergonomic Handle
21868HNN	10" Flat Bastard Cut File with Ergonomic Handle		

9 Pc. Maintenance File Set

- An all-encompassing 9-piece maintenance file set
- Includes five different 10" files
- Includes three 8" files and rasps
- Includes one 6" slim taper file
- For home and professional use
- Includes pouch for storage and organization



Cat. No.	Included Storage	Product Weight
22030NNN	Pouch	3.45 lb

Cat. No.	Description	Cat. No.	Description
03633NN	8" Flat Smooth Cut File	21854	10" Round Bastard Cut File
03732NN	10" Flat Smooth Cut File	21842NN	12" Mill Bastard Cut File
21868NN	10" Flat Bastard Cut File	21866NN	6" Slim Taper File
21857LN	8" Half Round Bastard Cut File	21860NNN	8" 4-in-Hand® Rasp and File
21858N	10" Half Round Bastard Cut File		

8 Pc. Machinist File Set

- File shapes and coarseness grades offer a range of shop uses for added versatility
- Complete set conveniently fits into rugged compact pouch for easy transport and storage
- Bastard-cut files are perfect for rough work and aggressive material removal
- Must-have file set for every machinist
- Includes pouch for storage and organization



Cat. No.	Included Storage	Product Weight
22025NNN	Pouch	3.35 lb

Cat. No.	Description	Cat. No.	Description
21868NN	10" Flat Bastard Cut File	21854	10" Round Bastard Cut File
03732NN	10" Flat Smooth Cut File	T21455	8" File Cleaner
21858N	10" Half Round Bastard Cut File	14255MN	7" Slim Taper File
21839NN	10" Mill Bastard Cut File	T13196	10" Square Bastard Cut File

5 Pc. General Purpose Set

- Set includes 10" half round bastard, 8" mill bastard, 8" mill smooth, 10" mill bastard, 6" slim taper files
- General-purpose files for a range of home and professional uses
- Bastard-cut files are perfect for rough work and aggressive material removal
- Slim taper files are excellent for precision work
- Includes pouch for storage and organization



Cat. No.	Included Storage	Product Weight
22040NNN	Pouch	1.80 lb

Cat. No.	Description	Cat. No.	Description
21858N	10" Half Round Bastard Cut File	21839NN	10" Mill Bastard Cut File
21832NN	8" Mill Bastard Cut File	21866NN	6" Slim Taper File
-	8" Mill Smooth Cut File		

3 Pc. File Pack

- For home and professional use
- Pack contains files for every purpose
- 6"/150mm slim taper file
- 6"/150mm round file
- 6"/150mm mill bastard file
- Includes pouch for storage and organization



Cat. No.	Included Storage	Product Weight
22015NNN	Pouch	0.28 lb

Cat. No.	Description
21825NN	6" Mill Bastard Cut File
21846NN	6" Round Bastard Cut File
21866NN	6" Slim Taper File

6 Pc. American Pattern File Assortment

- 4" file set includes warding, half round, round, hand, square, and slim taper files
- Must-have files to cover a broad range of uses
- All files come with handles
- Kit comes in bastard-cut only
- Includes pouch for storage and organization



Cat. No.	Included Storage	Product Weight
22062NNN	Pouch	0.40 lb

Cat. No.	Description	Cat. No.	Description
-	4" Warding Bastard Cut File with Wood Handle	-	4" Hand Bastard Cut File with Wood Handle
-	4" Half Round Bastard Cut File with Wood Handle	-	4" Square Bastard Cut File with Wood Handle
-	4" Round Bastard Cut File with Wood Handle	-	4" Slim Taper Bastard Cut File with Wood Handle

10" General Purpose Laminate File with Handle

- American pattern, bastard file
- Single-cut
- For use on plastic, aluminum, or laminate
- Rapid metal removal
- Results in fine to medium finish



Cat. No.	File Length	File Cut	Handled	Handle No.	Product Weight	Shelf Pack Qty.
21690NN	10 in	Bastard	Yes	#5	0.650 lb	6

Flat Files

- American pattern files available in bastard, second, and smooth cut in a variety of the most common lengths
- Ideal for machinists, machinery builders, ship and engine builders
- Can be used effectively by repairmen and others who require rapid removal of metal
- Rectangular cross section allows you to smooth and sharpen straight surfaces, while slight taper in width towards the file's point creates ease of access in slots
- Double-cut on the sides for rough filing and single-cut on the edges for a smooth finish



Cat. No.	File Length	File Cut	Handled	Packaging	Product Weight	Shelf Pack Qty.
03367NN	4 in	Bastard	No	Boxed	0.03 lb	12
21867NN	6 in	Bastard	No	Carded	0.15 lb	3
03467NN	6 in	Bastard	No	Boxed	0.10 lb	12
21862NN	8 in	Bastard	No	Carded	0.20 lb	3
03566NN	8 in	Bastard	No	Boxed	0.25 lb	12
21748HNN	8 in	Bastard	Yes	Carded	0.35 lb	6
21868NN	10 in	Bastard	No	Carded	0.48 lb	3
03665NN	10 in	Bastard	No	Boxed	0.45 lb	6
21868HNN	10 in	Bastard	Yes	Carded	0.60 lb	3
03762NN	12 in	Bastard	No	Carded	0.75 lb	6
03764NN	12 in	Bastard	No	Boxed	0.352	6
03863NN	14 in	Bastard	No	Boxed	0.545	6
03980NN	16 in	Bastard	No	Boxed	2.00 lb	6
03500NN	6 in	Second	No	Boxed	0.10 lb	12
03599NN	8 in	Second	No	Boxed	0.25 lb	12
03698NN	10 in	Second	No	Boxed	0.45 lb	6
03797NN	12 in	Second	No	Boxed	0.80 lb	6
03434NN	4 in	Smooth	No	Boxed	0.03 lb	12
03534NN	6 in	Smooth	No	Carded	0.15 lb	6
03533NN	6 in	Smooth	No	Boxed	0.10 lb	12
03633NN	8 in	Smooth	No	Carded	0.25 lb	6
03632NN	8 in	Smooth	No	Boxed	0.25 lb	12
03732NN	10 in	Smooth	No	Carded	0.60 lb	6
03731NN	10 in	Smooth	No	Boxed	0.45 lb	6
03830NN	12 in	Smooth	No	Boxed	0.80 lb	6
03929NN	14 in	Smooth	No	Boxed	0.545	6

Type "A" Flat Aluminum Files

- American pattern flat file specifically designed to file aluminum
- Special tooth construction eliminates clinging and clogging when filing aluminum
- Flat shape fits into restricted areas and removes material quickly
- All sizes have same number of teeth per inch
- Obtain a smooth finish by using a shearing cut in a leftward motion



Cat. No.	File Length	File Cut	Handled	Packaging	Product Weight	Shelf Pack Qty.
00024NN	8 in	Double Cut	No	Boxed	0.25 lb	12
00047NN	10 in	Double Cut	No	Boxed	0.45 lb	6
00070NN	12 in	Double Cut	No	Boxed	0.80 lb	6

Half Round Files

- American pattern files available in bastard, second, and smooth cut in a variety of the most common lengths
- Perfect for use on concave, convex, and flat surfaces
- Two-sided file is rounded on 1 side and flat on the other, so you can round out holes with ease
- Rounded sides of pipeliner files are single-cut, allowing you to quickly remove material from the work piece
- This pipeliner file from Crescent Nicholson features single-cut sides



Cat. No.	File Length	File Cut	Handled	Packaging	Product Weight	Shelf Pack Qty.
04695N	4 in	Bastard	No	Boxed	0.06 lb	12
21881N	6 in	Bastard	No	Carded	0.15 lb	6
04795N	6 in	Bastard	No	Boxed	0.13 lb	12
21857LN	8 in	Bastard	No	Carded	0.31 lb	3
21745N	8 in	Bastard	Yes	Carded	0.40 lb	6
04896N	8 in	Bastard	No	Boxed	0.27 lb	12
21858N	10 in	Bastard	No	Carded	0.56 lb	6
21746HN	10 in	Bastard	Yes	Carded	0.69 lb	6
04995N	10 in	Bastard	No	Boxed	0.55 lb	6
05090N	12 in	Bastard	No	Carded	0.90 lb	6
05094N	12 in	Bastard	No	Boxed	0.85 lb	6
05190N	14 in	Bastard	No	Boxed	1.50 lb	6
05194N	14 in	Bastard	No	Boxed	1.25 lb	6
05307N	16 in	Bastard	No	Boxed	1.99 lb	6
04729N	4 in	Second	No	Boxed	0.06 lb	12
04828N	6 in	Second	No	Boxed	0.10 lb	12
04927N	8 in	Second	No	Boxed	0.25 lb	12
05026N	10 in	Second	No	Boxed	0.49 lb	6
05125N	12 in	Second	No	Boxed	0.90 lb	6
04762N	4 in	Smooth	No	Boxed	0.06 lb	12
04861N	6 in	Smooth	No	Boxed	0.10 lb	12

Cat. No.	File Length	File Cut	Handled	Packaging	Product Weight	Shelf Pack Qty.
04960N	8 in	Smooth	No	Boxed	0.25 lb	12
05059N	10 in	Smooth	No	Boxed	0.53 lb	6
05158N	12 in	Smooth	No	Boxed	0.95 lb	6
05258N	14 in	Smooth	No	Boxed	1.28 lb	6

Hand Files

- American pattern files available in bastard, second, and smooth cut in a variety of the most common lengths
- Rectangular shape for efficient filing across a large surface
- Double-cut abrasive surfaces perfect for widening holes or smoothing a plane
- One safe edge to protect finished surfaces or your hands during use
- Coarseness matches flat files of the same length



Cat. No.	File Length	File Cut	Handled	Packaging	Product Weight	Shelf Pack Qty.
05738N	6 in	Bastard	No	Boxed	0.15 lb	12
05853N	8 in	Bastard	No	Boxed	0.30 lb	12
05968N	10 in	Bastard	No	Boxed	0.50 lb	6
06084N	12 in	Bastard	No	Boxed	0.95 lb	6
05771N	6 in	Second	No	Boxed	0.15 lb	12
05886N	8 in	Second	No	Boxed	0.30 lb	12
06001NN	10 in	Second	No	Boxed	0.50 lb	6
06117N	12 in	Second	No	Boxed	0.95 lb	6
05804N	6 in	Smooth	No	Boxed	0.15 lb	12
05919N	8 in	Smooth	No	Boxed	0.30 lb	12
06034N	10 in	Smooth	No	Boxed	0.50 lb	6
06150N	12 in	Smooth	No	Boxed	0.95 lb	6

Handy Files

- American pattern handy file
- Single cut on one side allows you to sharpen and smooth metal surfaces
- Double cut on the reverse side can be used for general filing and rapid stock removal
- Rectangular shape lets you smooth and sharpen straight surfaces
- File features one cut edge and one safe edge to let you work in tight spaces



Cat. No.	File Length	Handled	Packaging	Product Weight	Shelf Pack Qty.
06601NN	8 in	No	Carded	0.37 lb	6
06602NN	8 in	No	Boxed	0.60 lb	12
06686NN	12 in	No	Boxed	0.90 lb	6

Knife Files

- American pattern files available in bastard, second, and smooth cut in a variety of the most common lengths
- Used primarily by tool and diemakers who need to file acute angles
- Triangular shape is perfect for trade work and filing interior angles
- Double-cut on sides for faster material removal; single-cut on the sharp edge
- All Crescent Nicholson knife-shape files are supplied with safe backs



Cat. No.	File Length	File Cut	Handled	Packaging	Product Weight	Shelf Pack Qty.
06711N	4 in	Bastard	No	Boxed	0.03 lb	12
06804N	6 in	Bastard	No	Boxed	0.10 lb	12
06898N	8 in	Bastard	No	Boxed	0.15 lb	12
06992N	10 in	Bastard	No	Boxed	0.35 lb	6
07085N	12 in	Bastard	No	Boxed	0.70 lb	6
06836N	6 in	Second	No	Boxed	0.10 lb	12
06930N	8 in	Second	No	Boxed	0.15 lb	12
06773N	4 in	Smooth	No	Boxed	0.03 lb	12
06867N	6 in	Smooth	No	Boxed	0.10 lb	12
06961N	8 in	Smooth	No	Boxed	0.15 lb	12
07054N	10 in	Smooth	No	Boxed	0.35 lb	12

Long Angle Lathe Files

- American pattern flat long-angle lathe file
- Rapid, free-cutting files designed for lathe filing on wood or soft metals
- Rectangular shape is reliably strong and has a wide surface for faster filing
- Single-cut pattern is perfect for smoothing edges or precision work
- Safe edges designed to protect lathe and file when working close to the edges of a work piece
- Made on flat file blanks with a bastard-cut style that is coarser to the touch
- Cuts faster than regular mill files and leaves a smoother finish



Cat. No.	File Length	File Cut	Handled	Packaging	Product Weight	Shelf Pack Qty.
07835N	8 in	Fine	No	Boxed	0.30 lb	12
07842N	10 in	Fine	No	Boxed	0.50 lb	6
07851N	12 in	Fine	No	Boxed	0.93 lb	6
07863N	14 in	Fine	No	Boxed	1.40 lb	6
07657NN	10 in	Bastard	No	Boxed	0.45 lb	6
07688NN	12 in	Bastard	No	Boxed	0.80 lb	6
07719NN	14 in	Bastard	No	Boxed	1.10 lb	6

Magicut® Flat Files

- American pattern flat Magicut® file
- All-purpose file is ideal for machinists and removes stock rapidly for a fast and efficient application
- Rectangular shape allows you to smooth and sharpen straight surfaces
- Narrow chip breaker pattern created by steep, angled serrations helps quickly remove material and provides a smoother finish
- Slight taper in width towards the file's point creates ease of access in slots



Cat. No.	File Length	File Cut	Handled	Product Weight	Shelf Pack Qty.
07894NN	8 in	Single Cut	No	0.25 lb	12
07917NN	10 in	Single Cut	No	0.45 lb	6
07941NN	12 in	Single Cut	No	0.80 lb	6

Mill Files

- American pattern files available in bastard, second, and smooth cut in a variety of the most common lengths
- Sharpens mill or circular saws
- Great for draw filing and finishing metals
- Rectangular shape lets you smooth and sharpen straight surfaces
- Single-cut texture on the sides and edges for applying a smooth finish
- Two square edges allow you to make grooves fixed at the same width as the file
- All sizes taper slightly in width to improve access in slots



Cat. No.	File Length	File Cut	Handled	Packaging	Product Weight	Shelf Pack Qty.
08243NN	4 in	Bastard	No	Boxed	0.03 lb	12
21825NN	6 in	Bastard	No	Carded	0.18 lb	6
08354NN	6 in	Bastard	No	Boxed	0.10 lb	12
21687HNN	6 in	Bastard	Ergonomic	Carded	0.25 lb	6
21687NN	6 in	Bastard	Yes	Carded	0.25 lb	6
21832NN	8 in	Bastard	No	Carded	0.25 lb	6
08497NN	8 in	Bastard	No	Boxed	0.25 lb	12
21694HNN	8 in	Bastard	Ergonomic	Carded	0.35 lb	6
21694NN	8 in	Bastard	Yes	Carded	0.35 lb	6
21839NN	10 in	Bastard	No	Carded	0.60 lb	6
08642NN	10 in	Bastard	No	Boxed	0.45 lb	6
21701HNN	10 in	Bastard	Ergonomic	Carded	0.60 lb	6
21701NN	10 in	Bastard	Yes	Carded	0.60 lb	6
21842NN	12 in	Bastard	No	Carded	0.72 lb	3
08737NN	12 in	Bastard	No	Boxed	0.80 lb	6
21842HNN	12 in	Bastard	Ergonomic	Boxed	0.80 lb	-
08832NN	14 in	Bastard	No	Boxed	1.10 lb	6

Continued on next page

Mill Files ■ *Continued from previous page*

Cat. No.	File Length	File Cut	Handled	Packaging	Product Weight	Shelf Pack Qty.
08385NN	6 in	Second	No	Boxed	0.10 lb	12
08529NN	8 in	Second	No	Boxed	0.25 lb	12
08673NN	10 in	Second	No	Boxed	0.45 lb	12
08768NN	12 in	Second	No	Boxed	0.80 lb	6
08306NN	4 in	Smooth	No	Boxed	0.03 lb	12
08416NN	6 in	Smooth	No	Boxed	0.10 lb	12
08560NN	8 in	Smooth	No	Boxed	0.25 lb	12
08704NN	10 in	Smooth	No	Boxed	0.45 lb	12
08799NN	12 in	Smooth	No	Boxed	0.80 lb	6
08894NN	14 in	Smooth	No	Boxed	1.10 lb	6

1 and 2 Round Edge Mill Files

- Round edges are used where rounding gullets are preferred compared to sharp corners or squared gullets
- Rectangular shape
- Single cut on sides and edges
- Bastard cut
- Same as regular mill file except it has one round edge



Cat. No.	File Length	File Cut	Handled	Product Weight	Shelf Pack Qty.
09179N	10 in	Bastard	No	0.45 lb	12

Axe Sharpening Files

- American pattern axe sharpening file
- Ideal file for sharpening axes and miscellaneous garden tools
- Rectangular shape has a large surface area for faster filing work
- Double-cut on one side for rough filing and single-cut on the opposite for finishing
- This file has two safe edges to work easily in restricted confines without damage



Cat. No.	File Length	File Cut	Handled	Packaging	Product Weight	Shelf Pack Qty.
06706NN	8 in	Double / Single	No	Carded	0.50 lb	6
06704NN	8 in	Double / Single	No	Boxed	0.45 lb	12

Square Files

- Used on slots, keyways and general surface filing
- Double cut for faster material removal
- Tapered slightly towards point
- Larger sizes frequently preferred to corresponding flat files due to a heavier section and four filing surfaces



Cat. No.	File Length	Diameter	File Cut	Handled	Packaging	Product Weight	Shelf Pack Qty.
12790	4 in	5/32 in	Bastard	No	Boxed	0.03 lb	12
12967	6 in	1/4 in	Bastard	No	Boxed	0.10 lb	12
13081	8 in	5/16 in	Bastard	No	Boxed	0.10 lb	12
T13196	10 in	3/8 in	Bastard	No	Boxed	0.30 lb	12
13310	12 in	1/2 in	Bastard	No	Boxed	0.65 lb	6
13343	12 in	1/2 in	Second	No	Boxed	0.68 lb	6
12857	4 in	5/32 in	Smooth	No	Boxed	0.03 lb	12
13033	6 in	1/4 in	Smooth	No	Boxed	0.08 lb	12
13147	8 in	5/16 in	Smooth	No	Boxed	0.55 lb	12
13262	10 in	3/8 in	Smooth	No	Boxed	0.30 lb	12
13376	12 in	1/2 in	Smooth	No	Boxed	0.31 lb	6

Round Files

- American pattern files available in bastard, second, and smooth cut in a variety of the most common lengths
- Can be used to file circular openings or concave surfaces
- Single cut construction provides light removal of material and slightly smoother edges
- Slight taper in width towards the file's point creates ease of access in slots
- Round file can work in areas that a rectangular file cannot
- Safe point on round files helps reduce the risk of injury



Cat. No.	File Length	Diameter	File Cut	Handled	Packaging	Product Weight	Shelf Pack Qty.
11526NN	4 in	1/8 in	Bastard	No	Boxed	0.02 lb	12
21846NN	6 in	1/4 in	Bastard	No	Carded	0.12 lb	3
21708NN	6 in	1/4 in	Bastard	Yes	Carded	0.21 lb	6
21853	8 in	5/16 in	Bastard	No	Carded	0.16 lb	6
11904	8 in	5/16 in	Bastard	No	Boxed	0.14 lb	12
21715	8 in	5/16 in	Bastard	Yes	Carded	0.26 lb	6
21854	10 in	3/8 in	Bastard	No	Carded	0.30 lb	6
12019	10 in	3/8 in	Bastard	No	Boxed	0.25 lb	12
12131	12 in	1/2 in	Bastard	No	Carded	0.60 lb	6
12134	12 in	1/2 in	Bastard	No	Boxed	0.55 lb	6
12248	14 in	5/8 in	Bastard	No	Boxed	1.00 lb	6

■ *Continued on next page*

Round Files ■ *Continued from previous page*

Cat. No.	File Length	Diameter	File Cut	Handled	Packaging	Product Weight	Shelf Pack Qty.
11748NN	6 in	1/4 in	Second	No	Boxed	0.05 lb	12
11936	8 in	5/16 in	Second	No	Boxed	0.10 lb	12
12051	10 in	3/8 in	Second	No	Boxed	0.25 lb	12
12166	12 in	1/2 in	Second	No	Boxed	0.55 lb	6
11592NNN	4 in	1/8 in	Smooth	No	Boxed	0.02 lb	12
11969	8 in	5/16 in	Smooth	No	Boxed	0.20 lb	12
12084	10 in	3/8 in	Smooth	No	Boxed	0.30 lb	12
12199	12 in	1/2 in	Smooth	No	Boxed	0.55 lb	6

Round Chain Saw Files

- American pattern file with knurl cut
- Tighten tension on chain to firmly support cutters when filing
- Place file against beveled cutting surface of teeth 20° to 45° with saw
- File from inside to outside of cutter
- Sharpen all left-hand cutters on one side of chain and move to the other side and file all the right-hand cutters
- Check depth gauge height every 2 or 3 sharpenings
- Height between cutting teeth and depth gauge is between .020" to .030"
- Follow the manufacturer's specifications for safe usage

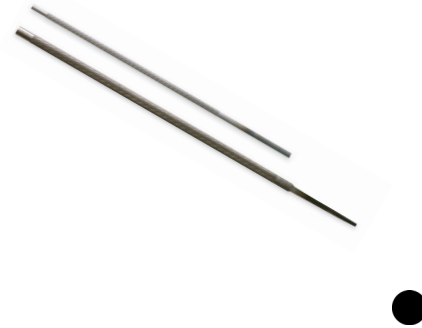

Cat. No.	File Length	Diameter	File Cut	Handled	Packaging	Product Weight	Shelf Pack Qty.
T01590	6 in	1/8 in	Knurl Cut	No	Carded	0.08 lb	6
02144N	6 in	1/8 in	Knurl Cut	No	Boxed	0.02 lb	6
T01630	6 in	5/32 in	Knurl Cut	No	Carded	0.08 lb	3
T01891	8 in	5/32 in	Knurl Cut	No	Carded	0.09 lb	6
T01765	8 in	3/16 in	Knurl Cut	No	Carded	0.09 lb	6
23861	8 in	13/64 in	Knurl Cut	No	Carded	0.18 lb	6
T01888	8 in	7/32 in	Knurl Cut	No	Carded	0.10 lb	3
02230B	8 in	7/32 in	Knurl Cut	No	Bagged	0.10 lb	4
T01974	8 in	1/4 in	Knurl Cut	No	Carded	0.14 lb	6
02147N	8 in	1/4 in	Knurl Cut	No	Boxed	0.10 lb	1

Depth Gauge Chain Saw File

- American pattern depth gauge chain saw file
- Rectangular shape
- Single cut, safe edges
- Used for filing and maintaining proper depth gauge clearance



Cat. No.	File Length	File Cut	Handled	Packaging	Product Weight	Shelf Pack Qty.
02244NN	8 in	Single	No	Boxed	0.08 lb	12

Taper Files

- American pattern taper file
- Expertly made to effectively file saws with 60° angle teeth
- Triangular shape makes accessing tight internal angles and squaring corners easy
- Single cut construction is ideal for sharpening tools, finish filing, and draw filing
- Edges set and cut for filing gullets between saw teeth
- Tapers slightly towards the point
- Select the right file when filing handsaws for long-lasting performance



Cat. No.	File Length	Style	File Cut	Handled	Packaging	Product Weight	Shelf Pack Qty.
13807MN	6 in	Regular	Single	No	Boxed	0.15 lb	12
13875MN	8 in	Regular	Single	No	Boxed	0.35 lb	12
13930NN	10 in	Regular	Single	No	Boxed	0.60 lb	12
14106MN	4 in	Slim	Single	No	Boxed	0.03 lb	12
14162MN	5 in	Slim	Single	No	Boxed	0.05 lb	12
21866NN	6 in	Slim	Single	No	Carded	0.11 lb	6
14224MN	6 in	Slim	Single	No	Boxed	0.09 lb	12
21729NN	6 in	Slim	Single	Yes	Carded	0.20 lb	6
21729HNN	6 in	Slim	Single	Ergonomic	Carded	1.00 lb	6
14255MN	7 in	Slim	Single	No	Boxed	0.14 lb	12
14290MN	8 in	Slim	Single	No	Boxed	0.30 lb	12
14341NNN	10 in	Slim	Single	No	Boxed	0.410 lb	12
14547MN	4 in	Extra Slim	Single	No	Boxed	0.02 lb	12
14599MN	5 in	Extra Slim	Single	No	Boxed	0.03 lb	12
21873NN	6 in	Extra Slim	Single	No	Carded	0.05 lb	6
14665MN	6 in	Extra Slim	Single	No	Boxed	0.05 lb	12
21736NN	6 in	Extra Slim	Single	Yes	Carded	0.19 lb	6
14729NN	8 in	Extra Slim	Single	No	Boxed	0.20 lb	12
14942MN	4 in	Double Extra Slim	Single	No	Boxed	0.02 lb	12
14992MN	5 in	Double Extra Slim	Single	No	Boxed	0.03 lb	12
21874NN	6 in	Double Extra Slim	Single	No	Carded	0.05 lb	6
15024NN	6 in	Double Extra Slim	Single	No	Boxed	0.05 lb	12
21743NN	6 in	Double Extra Slim	Single	Yes	Carded	0.20 lb	6
15056NN	7 in	Double Extra Slim	Single	No	Boxed	0.04 lb	12

Tungsten Point Files

- American pattern file with tungsten-tipped teeth
- Ideal for dressing distributor points that are tipped with tungsten or iridium
- Thin rectangular shape fits into restricted areas without compromising on strength
- Double-cut pattern is perfect for rougher work or removing material quickly
- Chisel-shaped teeth enter slots or gaps easily
- Handle-shaped tang can fit into larger cushioned handles or be a handle by itself



Cat. No.	File Length	File Cut	Handled	Packaging	Product Weight	Shelf Pack Qty.
02375NN	5.25 in	Double	No	Carded	0.03 lb	6
02373NN	5.25 in	Double	No	Boxed	0.05 lb	12

Warding Files

- American pattern files available in bastard, second, and smooth cut in a variety of the most common lengths
- Used primarily by locksmiths in repairing and filing the ward notches in keys
- Thin rectangular shape lets you work on fine objects or in small areas
- Double-cut on sides and single-cut on edges for more versatile performance
- Also suited for use in narrow spaces where other files won't fit



Cat. No.	File Length	File Cut	Handled	Packaging	Product Weight	Shelf Pack Qty.
16507NN	4 in	Bastard	No	Boxed	0.03 lb	12
16663NN	6 in	Bastard	No	Boxed	0.10 lb	12
16761NN	8 in	Bastard	No	Boxed	0.15 lb	12
16540N	4 in	Second	No	Boxed	0.03 lb	12
16573NN	4 in	Smooth	No	Boxed	0.03 lb	12
16729NN	6 in	Smooth	No	Boxed	0.10 lb	6
16827NN	8 in	Smooth	No	Boxed	0.15 lb	12

Coarse Half Round Wood File

- American pattern wood file
- Half round shape for use on concave, convex, and flat surfaces
- Used primarily in woodworking
- Specially coarse teeth for use on wood
- Made in same section and size as half round file



Cat. No.	File Length	File Cut	Handled	Packaging	Product Weight	Shelf Pack Qty.
17505N	10 in	Coarse	No	Boxed	0.50 lb	6

Three Square Files

- American pattern triangle file available in bastard and smooth cut styles
- Double-cut pattern is perfect for rougher work or removing material quickly
- For use by machinists for filing internal angles
- Filing taps and gutters
- More acute than right angles, clearing out square corners
- Sharp corners are slightly set and cut
- Cut to the point



Cat. No.	File Length	File Cut	Handled	Packaging	Product Weight	Shelf Pack Qty.
15925NNN	6 in	Bastard	No	Boxed	0.17 lb	12
16036NNN	8 in	Bastard	No	Boxed	0.40 lb	12
16147NNN	10 in	Bastard	No	Boxed	0.55 lb	12
15991NNN	6 in	Smooth	No	Boxed	0.17 lb	12
16102NNN	8 in	Smooth	No	Boxed	0.35 lb	12

3 Pc. 4-in-1 Combination Chisel and Wood Rasp Set

- Half round wood rasp for enlarging round surfaces
- Flat wood rasp for rapid stock removal
- Edge teeth for removal of materials in confined areas
- High quality steel chisel for cutting and scraping
- Co-molded handle for comfort and grip
- Striking cap



Cat. No.	Included Storage	Product Weight
WCSET3CMNNN	None	1.8 lb

Cat. No.	Description
-	1/2" Wood Chuck Combination Chisel and Wood Rasp
-	3/4" Wood Chuck Combination Chisel and Wood Rasp
-	1" Wood Chuck Combination Chisel and Wood Rasp

4-in-1 Hand Rasps

- 4-in-1 combination file and wood rasp
- Includes two types of rasps and two files
- Half-round wood rasp for enlarging round surfaces
- Flat wood rasp for rapid stock removal
- Both half-round and flat files for smoothing curved surfaces
- Precision engineered to provide maximum material removal per stroke and long product life
- Machine milled for precise material removal
- Reduces the number of files needed on a job

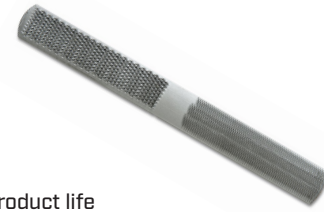

Cat. No.	Rasp Length	File Cut	Handled	Packaging	Product Weight	Shelf Pack Qty.
18924NNN	8 in	Rasp/Single/Double	No	Boxed	0.35 lb	6
21860NNN	8 in	Rasp/Single/Double	No	Carded	0.36 lb	6
21870NNN	9 in	Rasp/Single/Double	No	Carded	0.40 lb	6

Pattern Maker's Cabinet Rasps

- American pattern rasp
- Used primarily by cabinetmakers and other woodworking trade professionals
- Versatile half-round shape lets you work on a variety of projects
- Narrow-pattern cut edges let you file material in narrow, restricted areas
- Used when a smooth wood finish is required
- Tanged design integrates with any Crescent Nicholson adjustable handle



Cat. No.	Rasp Length	File Cut	Code No.	Handled	Packaging	Product Weight	Shelf Pack Qty.
18846N	10 in	Second	49	No	Boxed	0.25 lb	6
18861N	10 in	Smooth	50	No	Boxed	0.25 lb	6

Cabinet Rasps

- American pattern rasp
- Used by cabinetmakers and woodworkers
- Half-round shape for use on concave, convex, and flat surfaces
- Single cut on edges for applying a smooth finish
- Curved side of rasps similar to half-round rasps but has larger radius
- Tanged design integrates with any Crescent Nicholson adjustable handle



Cat. No.	Rasp Length	File Cut	Handled	Packaging	Product Weight	Shelf Pack Qty.
17615N	8 in	Regular Second	No	Boxed	0.23 lb	12
17683N	10 in	Regular Second	No	Boxed	0.40 lb	6
17751N	12 in	Regular Second	No	Boxed	0.80 lb	6

Wood Rasps

- American pattern rasp with a bastard cut
- Used by woodworkers, hobbyists and plumbers
- Ideal for use removing stock from wood or soft metal materials
- Used in places for which their shapes make them particularly effective
- Tanged design integrates with any Crescent Nicholson adjustable handle



Cat. No.	Rasp Length	File Shape	File Cut	Handled	Packaging	Product Weight	Shelf Pack Qty.
19136N	10 in	Flat	Bastard	No	Boxed	0.65 lb	6
21878N	8 in	Half Round	Bastard	No	Carded	0.30 lb	6
19394N	8 in	Half Round	Bastard	No	Boxed	0.25 lb	12
19427N	10 in	Half Round	Bastard	No	Boxed	0.65 lb	6
19460N	12 in	Half Round	Bastard	No	Boxed	0.90 lb	6
19493N	14 in	Half Round	Bastard	No	Boxed	1.40 lb	6
19875	10 in	Round	Bastard	No	Boxed	0.26 lb	12

Farrier's Handy Rasp

- Farrier's American pattern rasp
- Rectangular shape
- Single cut on edges
- Comfortable cushion grip at point and handle
- Rasp teeth on one side, file teeth on other
- Has 6 teeth per row vs. 5 teeth per row on standard horse rasps



Cat. No.	Rasp Length	File Cut	Handled	Packaging	Product Weight	Shelf Pack Qty.
18155N	14 in	Rasp/Double	Yes	Boxed	1.45 lb	5

Magicut® Plater's Special Horse Rasp

- American pattern rasp
- Maximum cutting surface design gives rapid removal and smoother finish
- Single cut on edges for applying a smooth finish
- Opposite side has the unique Crescent Nicholson Magicut® file pattern
- Narrow chip breakers created by steep angled serrations reduce clogging
- Rectangular shape lets you smooth and sharpen straight surfaces
- Faster cutting than conventional horse rasps
- Has 6 teeth per row vs. 5 teeth per row on standard horse rasps
- Tanged design integrates with any Crescent Nicholson adjustable handle

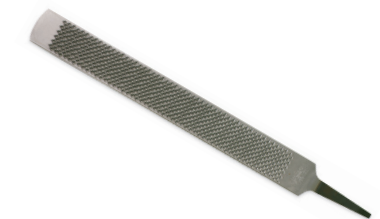

Cat. No.	Rasp Length	File Cut	Handled	Packaging	Product Weight	Shelf Pack Qty.
18130N	14 in	Rasp/Magicut®	No	Boxed	1.35 lb	6

Horse Rasp

- American pattern rasp
- Rectangular shape provides maximum surface area for faster filing
- Single cut on edges for applying a smooth finish
- Tanged design integrates with any Crescent Nicholson adjustable handle
- Features rasp teeth down one side and file teeth down the other side
- Heavy-duty design is thicker than Plater's Special and is ideal for hot rasping



Cat. No.	Rasp Length	File Cut	Handled	Packaging	Product Weight	Shelf Pack Qty.
18057N	14 in	Rasp/Double	No	Boxed	2.15 lb	6

Horse Rasps with Plain 1/2 File

- American pattern rasp and plain 1/2 file on opposite ends of the same tool
- Designed for shoeing racehorses, riding horses, and ponies
- Double-ended with rasp teeth on one side and file teeth on the other
- Teeth on both sides of the body for variable use
- Rectangular shape is easy to transport and provides maximum filing surface



Cat. No.	Rasp Length	File Cut	Handled	Packaging	Product Weight	Shelf Pack Qty.
17873N	12 in	Rasp Punch/Coarse	No	Boxed	1.10 lb	6
17903N	14 in	Rasp Punch/Coarse	No	Boxed	1.60 lb	6
17910N	14 in	Rasp Punch/Coarse	No	Pouch	1.60 lb	6

6 Pc. Hobby File Set

- 5-1/2" Swiss pattern files
- Selection of six miniature files with a fine cut for intricate work
- One each of equaling, half round, flat, round, three square, square files
- Ideal for handicrafts and hobbies
- Double-cut teeth for rapid removal of material
- Includes pouch for storage and organization

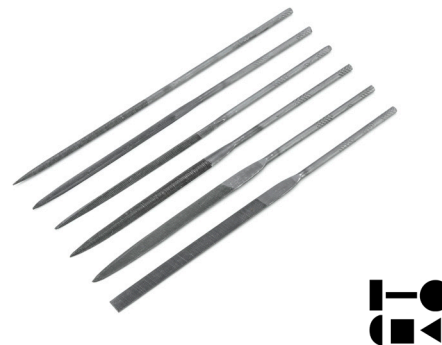

Cat. No.	Included Storage	Product Weight
42030L	Pouch	0.010 lb

Cat. No.	Description	Cat. No.	Description
-	5-1/2" Fine Cut Equaling File	-	5-1/2" Fine Cut Round File
-	5-1/2" Fine Cut Half Round File	-	5-1/2" Fine Cut Three Square File
-	5-1/2" Fine Cut Flat File	-	5-1/2" Fine Cut Square File

X.F.® Swiss Pattern Needle File Assortment Sets

- Swiss pattern files, made to more exacting measurements than American pattern files
- Used primarily by jewelers, diemakers, watchmakers, fine toolmakers, and other trades professionals
- Knurled handles give you an easy and secure grip on the files
- Excellent for precise and intricate work
- Assortment of 12 file shapes with different cuts
- Assortment also includes files for smoothing joints or making markings
- Includes pouch for storage and organization

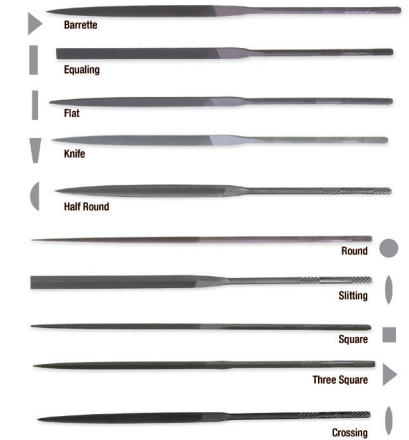

Cat. No.	Included Storage	Product Weight
37029	Pouch	0.10 lb

Cat. No.	Description	Cat. No.	Description
-	Joint File	-	4" 0 Cut Half Round File
-	Marking File	-	4" 0 Cut Round File
-	4" 0 Cut Barrette File	-	4" 0 Cut Slitting File
-	4" 0 Cut Equaling File	-	4" 0 Cut Square File
-	4" 0 Cut Flat File	-	4" 0 Cut Three Square File
-	4" 0 Cut Knife File	-	4" 0 Cut Crossing File

Cat. No.	Included Storage	Product Weight
37392	Pouch	0.20 lb

Cat. No.	Description	Cat. No.	Description
-	Joint File	-	5-1/2" 0 Cut Half Round File
-	Marking File	-	5-1/2" 0 Cut Round File
-	5-1/2" 0 Cut Barrette File	-	5-1/2" 0 Cut Slitting File
-	5-1/2" 0 Cut Equaling File	-	5-1/2" 0 Cut Square File
-	5-1/2" 0 Cut Flat File	-	5-1/2" 0 Cut Three Square File
-	5-1/2" 0 Cut Knife File	-	5-1/2" 0 Cut Crossing File

Cat. No.	Included Storage	Product Weight
37398	Pouch	0.20 lb

Cat. No.	Description	Cat. No.	Description
-	Joint File	-	5-1/2" 2 Cut Half Round File
-	Marking File	-	5-1/2" 2 Cut Round File
-	5-1/2" 2 Cut Barrette File	-	5-1/2" 2 Cut Slitting File
-	5-1/2" 2 Cut Equaling File	-	5-1/2" 2 Cut Square File
-	5-1/2" 2 Cut Flat File	-	5-1/2" 2 Cut Three Square File
-	5-1/2" 2 Cut Knife File	-	5-1/2" 2 Cut Crossing File

Cat. No.	Included Storage	Product Weight
37404	Pouch	0.20 lb

Cat. No.	Description	Cat. No.	Description
-	Joint File	-	5-1/2" 4 Cut Half Round File
-	Marking File	-	5-1/2" 4 Cut Round File

Continued on next page

X.F.® Swiss Pattern Needle File Assortment Sets ■ *Continued from previous page*

Cat. No.	Description	Cat. No.	Description
-	5-1/2" 4 Cut Barrette File	-	5-1/2" 4 Cut Slitting File
-	5-1/2" 4 Cut Equaling File	-	5-1/2" 4 Cut Square File
-	5-1/2" 4 Cut Flat File	-	5-1/2" 4 Cut Three Square File
-	5-1/2" 4 Cut Knife File	-	5-1/2" 4 Cut Crossing File

Cat. No.	Included Storage	Product Weight
37767	Pouch	0.25 lb

Cat. No.	Description	Cat. No.	Description
-	Joint File	-	6-1/4" 4 Cut Half Round File
-	Marking File	-	6-1/4" 4 Cut Round File
-	6-1/4" 4 Cut Barrette File	-	6-1/4" 4 Cut Slitting File
-	6-1/4" 4 Cut Equaling File	-	6-1/4" 4 Cut Square File
-	6-1/4" 4 Cut Flat File	-	6-1/4" 4 Cut Three Square File
-	6-1/4" 4 Cut Knife File	-	6-1/4" 4 Cut Crossing File

Cat. No.	Included Storage	Product Weight
T37035	Pouch	0.13 lb

Cat. No.	Description	Cat. No.	Description
-	Joint File	-	4" 2 Cut Half Round File
-	Marking File	-	4" 2 Cut Round File
-	4" 2 Cut Barrette File	-	4" 2 Cut Slitting File
-	4" 2 Cut Equaling File	-	4" 2 Cut Square File
-	4" 2 Cut Flat File	-	4" 2 Cut Three Square File
-	4" 2 Cut Knife File	-	4" 2 Cut Crossing File

Cat. No.	Included Storage	Product Weight
T37755	Pouch	0.25 lb

Cat. No.	Description	Cat. No.	Description
-	Joint File	-	6-1/4" 0 Cut Half Round File
-	Marking File	-	6-1/4" 0 Cut Round File
-	6-1/4" 0 Cut Barrette File	-	6-1/4" 0 Cut Slitting File
-	6-1/4" 0 Cut Equaling File	-	6-1/4" 0 Cut Square File
-	6-1/4" 0 Cut Flat File	-	6-1/4" 0 Cut Three Square File
-	6-1/4" 0 Cut Knife File	-	6-1/4" 0 Cut Crossing File

Cat. No.	Included Storage	Product Weight
T37761	Pouch	0.25 lb

Cat. No.	Description	Cat. No.	Description
-	Joint File	-	6-1/4" 2 Cut Half Round File
-	Marking File	-	6-1/4" 2 Cut Round File
-	6-1/4" 2 Cut Barrette File	-	6-1/4" 2 Cut Slitting File
-	6-1/4" 2 Cut Equaling File	-	6-1/4" 2 Cut Square File
-	6-1/4" 2 Cut Flat File	-	6-1/4" 2 Cut Three Square File
-	6-1/4" 2 Cut Knife File	-	6-1/4" 2 Cut Crossing File

Needle Files

- Swiss pattern files, made to more exacting measurements than American pattern files
- Used primarily by jewelers, diemakers, watchmakers, and other fine toolmakers
- Knurled handle for a better grip in hand or in a handle
- Excellent for precise and intricate work



Cat. No.	File Length	Style	File Cut	Handled	Packaging	Product Weight	Shelf Pack Qty.
T37277	4 in	Barrette	0	No	Boxed	0.01 lb	12
37640	5.5 in	Barrette	0	No	Boxed	0.01 lb	12
37752	5.5 in	Barrette	0	No	Boxed	0.01 lb	12
T38003	6.25 in	Barrette	0	No	Boxed	0.02 lb	12
T38115	6.25 in	Barrette	0	No	Boxed	0.02 lb	12
T37647	5.5 in	Barrette	2	No	Boxed	0.01 lb	12
T38010	6.25 in	Barrette	2	No	Boxed	0.02 lb	12
37500	5.5 in	Crossing	0	No	Boxed	0.01 lb	12
37863	6.25 in	Crossing	0	No	Boxed	0.02 lb	12
T37870	6.25 in	Crossing	2	No	Boxed	0.03 lb	12
37612	5.5 in	Equaling	0	No	Boxed	0.01 lb	12
T37249	4 in	Equaling	0	No	Boxed	0.01 lb	12
T37975	6.25 in	Equaling	0	No	Boxed	0.02 lb	12
37256	4 in	Equaling	2	No	Boxed	0.01 lb	12
37619	5.5 in	Equaling	2	No	Boxed	0.01 lb	12
T37982	6.25 in	Equaling	2	No	Boxed	0.02 lb	12
T37626	5.5 in	Equaling	4	No	Boxed	0.01 lb	12
T37989	6.25 in	Equaling	4	No	Boxed	0.02 lb	12
T37996	6.25 in	Equaling	6	No	Boxed	0.02 lb	12
T37109	4 in	Flat	0	No	Boxed	0.02 lb	12
T37472	5.5 in	Flat	0	No	Boxed	0.01 lb	12
T37835	6.25 in	Flat	0	No	Boxed	0.02 lb	12
37116	4 in	Flat	2	No	Boxed	0.02 lb	12
37842	6.25 in	Flat	2	No	Boxed	0.02 lb	12
T37479	5.5 in	Flat	2	No	Boxed	0.01 lb	12
37486	5.5 in	Flat	4	No	Boxed	0.01 lb	12
37849	6.25 in	Flat	4	No	Boxed	0.02 lb	12
37081	4 in	Half Round	0	No	Boxed	0.10 lb	12
T37444	5.5 in	Half Round	0	No	Boxed	0.01 lb	12
T37807	6.25 in	Half Round	0	No	Boxed	0.02 lb	12
T37088	4 in	Half Round	2	No	Boxed	0.02 lb	12
T37451	5.5 in	Half Round	2	No	Boxed	0.02 lb	12
T37814	6.25 in	Half Round	2	No	Boxed	0.02 lb	12
T37458	5.5 in	Half Round	4	No	Boxed	0.01 lb	12
T37821	6.25 in	Half Round	4	No	Boxed	0.02 lb	12
37828	6.25 in	Half Round	6	No	Boxed	0.02 lb	12
37891	6.25 in	Knife	0	No	Boxed	0.02 lb	12

■ *Continued on next page*

Needle Files ■ *Continued from previous page*

Cat. No.	File Length	Style	File Cut	Handled	Packaging	Product Weight	Shelf Pack Qty.
T37165	4 in	Knife	0	No	Boxed	0.01 lb	12
37898	6.25 in	Knife	2	No	Boxed	0.02 lb	12
T37172	4 in	Knife	2	No	Boxed	0.01 lb	12
37416	5.5 in	Round	0	No	Boxed	0.01 lb	12
37779	6.25 in	Round	0	No	Boxed	0.01 lb	12
T37053	4 in	Round	0	No	Boxed	0.02 lb	12
37060	4 in	Round	2	No	Boxed	0.02 lb	12
T37423	5.5 in	Round	2	No	Boxed	0.01 lb	12
T37786	6.25 in	Round	2	No	Boxed	0.02 lb	12
37430	5.5 in	Round	4	No	Boxed	0.01 lb	12
37793	6.25 in	Round	4	No	Boxed	0.02 lb	12
T37800	6.25 in	Round	6	No	Boxed	0.02 lb	12
38059	6.25 in	Slitting	0	No	Boxed	0.02 lb	12
T37703	5.5 in	Slitting	2	No	Boxed	0.02 lb	12
T37193	4 in	Square	0	No	Boxed	0.01 lb	12
T37556	5.5 in	Square	0	No	Boxed	0.01 lb	12
T37919	6.25 in	Square	0	No	Boxed	0.02 lb	12
37200	4 in	Square	2	No	Boxed	0.01 lb	12
37926	6.25 in	Square	2	No	Boxed	0.02 lb	12
T37563	5.5 in	Square	2	No	Boxed	0.01 lb	12
37947	6.25 in	Three Square	0	No	Boxed	0.02 lb	12
T37221	4 in	Three Square	0	No	Boxed	0.01 lb	12
T37584	5.5 in	Three Square	0	No	Boxed	0.01 lb	12
37228	4 in	Three Square	2	No	Boxed	0.01 lb	12
37591	5.5 in	Three Square	2	No	Boxed	0.01 lb	12
T37954	6.25 in	Three Square	2	No	Boxed	0.02 lb	12
T37598	5.5 in	Three Square	4	No	Boxed	0.02 lb	12
T37961	6.25 in	Three Square	4	No	Boxed	0.02 lb	12

Silversmith's Rifflers

- 7-1/2" silversmith's riffler
- Made to more exacting measurements than American pattern files
- Made in approximately 7 1/8"/180mm lengths only
- Most often used for deburring, wood working, and sculpting
- Ideal for fine work



Cat. No.	File Length	Style	File Cut	Handled	Packaging	Product Weight	Shelf Pack Qty.
41018	7.5 in	3	2	No	Boxed	0.07 lb	12
T41096	7.5 in	10	0	No	Boxed	0.05 lb	12
41102	7.5 in	10	2	No	Boxed	0.06 lb	12

Die Sinker's Rifflers

- Made to more exacting measurements than American pattern files
- Used by tool and die makers, jewelers, model makers and home craftsman
- Made in approximately 6-1/2" length
- Each riffler identified by number



Cat. No.	File Length	File Shape	Style	File Cut	Handled	Packaging	Product Weight	Shelf Pack Qty.
36018N	6.5 in	Knife	5	2	No	Boxed	0.02 lb	12
T35976	6.5 in	Round	1	0	No	Boxed	0.02 lb	12
T35982	6.5 in	Round	1	2	No	Boxed	0.02 lb	12
T36054	6.5 in	Half Round	7	2	No	Boxed	0.02 lb	12

Pillar Files

- Made to more exacting measurements than American pattern files
- Rectangular shape
- Double cut on two sides only
- Safe edges
- Tapered in thickness



Cat. No.	File Length	Style	File Cut	Handled	Packaging	Product Weight	Shelf Pack Qty.
39855N	4 in	Regular	00	No	Boxed	0.04 lb	12
39861N	4 in	Regular	0	No	Boxed	0.04 lb	12
39873N	4 in	Regular	2	No	Boxed	0.04 lb	12
39881N	4 in	Regular	4	No	Boxed	0.04 lb	12
39893N	6 in	Regular	00	No	Boxed	0.10 lb	12
39899N	6 in	Regular	0	No	Boxed	0.10 lb	12
39905N	6 in	Regular	1	No	Boxed	0.10 lb	12
39911N	6 in	Regular	2	No	Boxed	0.10 lb	12
39923N	6 in	Regular	4	No	Boxed	0.10 lb	12
39929N	6 in	Regular	00	No	Boxed	0.23 lb	12
39935N	8 in	Regular	0	No	Boxed	0.23 lb	12
39947N	8 in	Regular	2	No	Boxed	0.23 lb	12
39965N	10 in	Regular	00	No	Boxed	0.45 lb	6
39971N	10 in	Regular	0	No	Boxed	0.45 lb	6
39992N	12 in	Regular	00	No	Boxed	0.74 lb	6
40076N	6 in	Narrow	0	No	Boxed	0.08 lb	12
40082N	6 in	Narrow	1	No	Boxed	0.08 lb	12
40088N	6 in	Narrow	2	No	Boxed	0.08 lb	12
40222N	4 in	Extra Narrow	2	No	Boxed	0.02 lb	12
40242N	6 in	Extra Narrow	00	No	Boxed	0.05 lb	12
40248N	6 in	Extra Narrow	0	No	Boxed	0.05 lb	12
40254N	6 in	Extra Narrow	1	No	Boxed	0.05 lb	12

■ *Continued on next page*

Pillar Files ■ *Continued from previous page*

Cat. No.	File Length	Style	File Cut	Handled	Packaging	Product Weight	Shelf Pack Qty.
40260N	6 in	Extra Narrow	2	No	Boxed	0.05 lb	12
40281N	8 in	Extra Narrow	00	No	Boxed	0.11 lb	12
40287N	8 in	Extra Narrow	0	No	Boxed	0.11 lb	12

Equaling Files

- Made to more exacting measurements than American pattern files
- Used by tool and die makers, jewelers, model makers and home craftsman
- Rectangular shape
- Double-cut on sides; single-cut on edges
- Parallel in both width and thickness for their entire length



Cat. No.	File Length	File Cut	Handled	Packaging	Product Weight	Shelf Pack Qty.
36219N	4 in	0	No	Boxed	0.05 lb	12
36227N	4 in	2	No	Boxed	0.05 lb	12
36253N	6 in	2	No	Boxed	0.10 lb	12
36281N	8 in	2	No	Boxed	0.25 lb	12

Warding Files

- Made to more exacting measurements than American pattern files
- Used by locksmiths and anywhere a thin file is required
- Width tapers slightly to point
- Thin rectangular shape with a 1:8 thickness-to-width ratio
- Made in much finer cuts, which vary from No. 0 [coarse] to No. 2 [less coarse]



Cat. No.	File Length	File Cut	Handled	Packaging	Product Weight	Shelf Pack Qty.
41612N	6 in	0	No	Boxed	0.10 lb	12
41618N	6 in	2	No	Boxed	0.10 lb	12
41636N	8 in	0	No	Boxed	0.15 lb	12

Barrette Files

- Made to more exacting measurements than American pattern files
- Used by tool and die makers, jewelers, model makers and home craftsman
- Recommended for those who do superfine precision filing
- Double cut, wide flat sides
- Flat on one side, backs are beveled on edges as indicated by cross section
- Back and beveled edges are safe
- 33° angle



Cat. No.	File Length	File Cut	Handled	Packaging	Product Weight	Shelf Pack Qty.
35025N	4 in	00	No	Boxed	0.05 lb	12
35031N	4 in	0	No	Boxed	0.05 lb	12
35061N	6 in	0	No	Boxed	0.10 lb	12
35073N	6 in	2	No	Boxed	0.10 lb	12

Hot Die Barrette Files

- X.F.® files, Swiss pattern Barrette file, hot die, cut no. 00
- Made to more exacting measurements than American pattern files
- Used by tool and die makers, jewelers, model makers and home craftsman
- Recommended for superfine precision filing
- Double cut, wide flat sides
- Flat on one side; backs are beveled on edges as indicated by cross-section
- Back and beveled edges are safe
- 33° angle
- Approximate point thickness is .040"/1.10mm
- Thinner point than standard Barrette files



Cat. No.	File Length	File Cut	Handled	Packaging	Product Weight	Shelf Pack Qty.
35108N	3 in	00	No	Boxed	0.02 lb	12
35114N	4 in	00	No	Boxed	0.03 lb	12

Pippin File

- X.F.® files, Swiss pattern Pippin file, cut no. 2
- Made to more exacting measurements than American pattern files
- Rounded back tapers to sharp edge
- Tapers to point in both width and thickness
- Sometimes called "appleseed" files



Cat. No.	File Length	File Cut	Handled	Packaging	Product Weight	Shelf Pack Qty.
TT40506	6 in	2	No	Boxed	0.08 lb	12

Half Round Files

- Made to more exacting measurements than American pattern files
- Used by tool and die makers, jewelers, model makers and home craftsmen
- Double cut on both flat and half-round sides
- Tapered in thickness and width to point
- Half round shape
- Made in much finer cuts, which vary from No. 00 [coarsest] to No. 4 [finest]



Cat. No.	File Length	File Cut	Handled	Packaging	Product Weight	Shelf Pack Qty.
36521N	6 in	0	No	Boxed	0.10 lb	12
36527N	6 in	1	No	Boxed	0.10 lb	12
36533N	6 in	2	No	Boxed	0.10 lb	12
36539N	6 in	3	No	Boxed	0.10 lb	12
36545N	6 in	4	No	Boxed	0.10 lb	12
36557N	8 in	00	No	Boxed	0.20 lb	12
36563N	8 in	0	No	Boxed	0.20 lb	12
36569N	8 in	1	No	Boxed	0.20 lb	12

Round Files

- Made to more exacting measurements than American pattern files
- Round shape
- Double cut
- Tapers throughout length to fine point
- Made in much finer cuts, which vary from No. 00 [coarsest] to No. 4 [finest]



Cat. No.	File Length	Diameter	File Cut	Handled	Packaging	Product Weight	Shelf Pack Qty.
40580N	4 in	1/8 in	0	No	Boxed	0.01 lb	12
40645N	6 in	3/16 in	00	No	Boxed	0.04 lb	12
40651N	6 in	3/16 in	0	No	Boxed	0.04 lb	12
40663N	6 in	3/16 in	2	No	Boxed	0.04 lb	12
40687N	8 in	1/4 in	00	No	Boxed	0.08 lb	12
40699N	8 in	1/4 in	1	No	Boxed	0.08 lb	12
40705N	8 in	1/4 in	2	No	Boxed	0.08 lb	12
40717N	8 in	1/4 in	4	No	Boxed	0.08 lb	12

4 Pc. Thread Restoring File Set

- Ideal for restoring damaged or worn external threads on bolts and pipes
- Thread restoring files can be used with 8 different thread sizes, allowing you to find a true fit effortlessly
- 4-piece set offers 4 convenient file sizes for quick and effective application
- Color caps on tubes help identify the file type, so you can select the tool you need with ease
- Type 1 black cap: regular bolt; 11, 12, 13, 14, 16, 18, 20, 24 TPI
- Type 2 red cap: extra-fine/extra-coarse bolt; 9, 10, 12, 16, 20, 27, 28, 32 TPI
- Type 7 green cap: regular pipe; 8, 10, 11 1/2, 14, 16, 18, 24, 27 TPI
- Type 8 blue cap: metric bolt; .80, 1.00, 1.25, 1.50, 1.75, 2.00, 2.50, 3.00 mm
- Includes pouch for storage and organization



Cat. No.	Included Storage	Product Weight
T33024	Pouch	1.60 lb

Cat. No.	Description	Cat. No.	Description
T33001	No. 1 Regular Bolt Thread Restoring File	-	No. 7 Regular Pipe Restoring File
T33007	No. 2 Extra Fine/Extra Coarse Thread Restoring File	T33016	No. 8 Metric Bolt Thread Restoring File

Thread Restoring Files

- Used to restore damaged or worn external threads on bolts, pipes, etc.
- Each thread restoring file will work with 8 different thread sizes
- Color caps on tubes
- Excellent for bolt, thread, and pipe repairs



Cat. No.	File Length	Style	File Cut	Handled	Packaging	Product Weight	Shelf Pack Qty.
T33001	8.44 in	1	Regular Bolt	No	Bagged	0.40 lb	16
T33007	8.44 in	2	Ex Fine/Ex Coarse Bolt	No	Bagged	0.40 lb	16
T33016	8.44 in	8	Metric Bolt	No	Bagged	0.35 lb	12

Milled Tooth Bodifiles

- A flexible milled tooth body file with a curved-tooth pattern and no tang
- For smooth, rapid work on cast iron, bronze, lead, babbitt, or aluminum
- A good choice for filing down zinc or plastic stock
- Cuts any steel up to the hardness of annealed tool steel
- Rectangular file for maximum material removal
- Curved-cut pattern that leaves a smooth finish in even hard metals
- Pitch and rake designed to avoid pinning or binding even during heavy use
- 8 teeth per inch; cut: 50-908 standard



Cat. No.	File Length	Teeth per inch	File Cut	Handled	Packaging	Product Weight	Shelf Pack Qty.
20189NN	14 in	8	50-908 Standard	No	Boxed	0.75 lb	6

File Cleaners

- Perfect for general cleaning of file teeth
- Helps remove fillings, dirt, rust, burrs, corrosion, and most buildups of foreign material on metal
- File card and brush unclog teeth on finer cut files, allowing the abrasive to cut properly each time
- Wood base construction offers durability and ease of grip, so you can work confidently over time
- Cleaning files helps with long lasting performance



Cat. No.	File Length	Description	Handled	Packaging	Product Weight	Shelf Pack Qty.
T21455	8 in	8" File Cleaner	Yes	Carded	0.14 lb	6
21458	10 in	10" File Card	Yes	Boxed	0.30 lb	10
21467	10 in	10" File Card and Brush	Yes	Boxed	0.30 lb	6

Universal Handle

- Handle holds files, reamers, hacksaw blades, and other tools, allowing you to work with a full line of instruments
- Adjustable, steel jaws clamp to the entire length of the tang for a powerful hold in tough working environments
- Large, quick adjusting knob offers fast tool changes, so you can swap files with ease
- Co-molded grip provides comfort and control and the longer, wider handle fits perfectly in your hand for more maneuverability
- Note that this product includes only a handle, and not a filing surface



Cat. No.	Overall Length	Packaging	Product Weight	Shelf Pack Qty.
21474U	5 in	Carded	0.30 lb	3

Ergonomic File Handle

- Comes with two interchangeable cushion inserts
- Designed to fit most popular files
- Sleek black design
- Rubber-coated, ergonomic grip shaped for better comfort and control
- Rear taper, wide middle, and flared neck increases push force



Cat. No.	Overall Length	Packaging	Product Weight	Shelf Pack Qty.
21474H	4.5 in	Carded	0.15 lb	6

Plastic Screw-on Handles

- Screw-on design fits most popular files
- For professionals or DIYers
- Handle made of strong high-impact material
- Contoured to fit hand for straight, lathe, and draw filing
- Non-slip textured finish for better grip



Cat. No.	Overall Length	Handle No.	Packaging	Product Weight	Shelf Pack Qty.
T21484	3.5 in	PH1	Carded	0.10 lb	12
21493	3.75 in	PH2	Carded	0.10 lb	12
T21502	3.75 in	PH3	Carded	0.10 lb	12
21512	4.125 in	PH4	Carded	0.15 lb	12
21513	4.125 in	PH5	Carded	0.13 lb	12
21514	4.75 in	PH6	Carded	0.20 lb	12
21515	5 in	PH7	Carded	0.20 lb	12
21516	5 in	PH8	Carded	0.20 lb	12

Metal Ferruled Wooden Handles

- Made from close grain hardwood with wax finish
- Handles have strong nickel-plated metal ferrules
- A selection of handles to fit most popular files
- Non-slip wax finish for better grip
- For professionals or DIYers



Cat. No.	Overall Length	Handle No.	Packaging	Product Weight	Shelf Pack Qty.
21470N	5.75 in	000	Boxed	0.20 lb	12
21471N	5.75 in	00	Boxed	0.19 lb	12
21528N	5.25 in	0	Carded	0.20 lb	6
21476N	5.25 in	0	Boxed	0.10 lb	12
21526N	4.875 in	1	Carded	0.30 lb	6
21485N	4.875 in	1	Boxed	0.11 lb	12
21524N	4.5 in	2	Carded	0.12 lb	6
21494N	4.5 in	2	Boxed	0.10 lb	12
21522N	4.125 in	3	Carded	0.09 lb	6
21503N	4.125 in	3	Boxed	0.08 lb	12
21520N	3.75 in	4	Carded	0.10 lb	6
21511N	3.75 in	4	Boxed	0.05 lb	12
TG4N	5 in	RASP	Boxed	0.15 lb	12

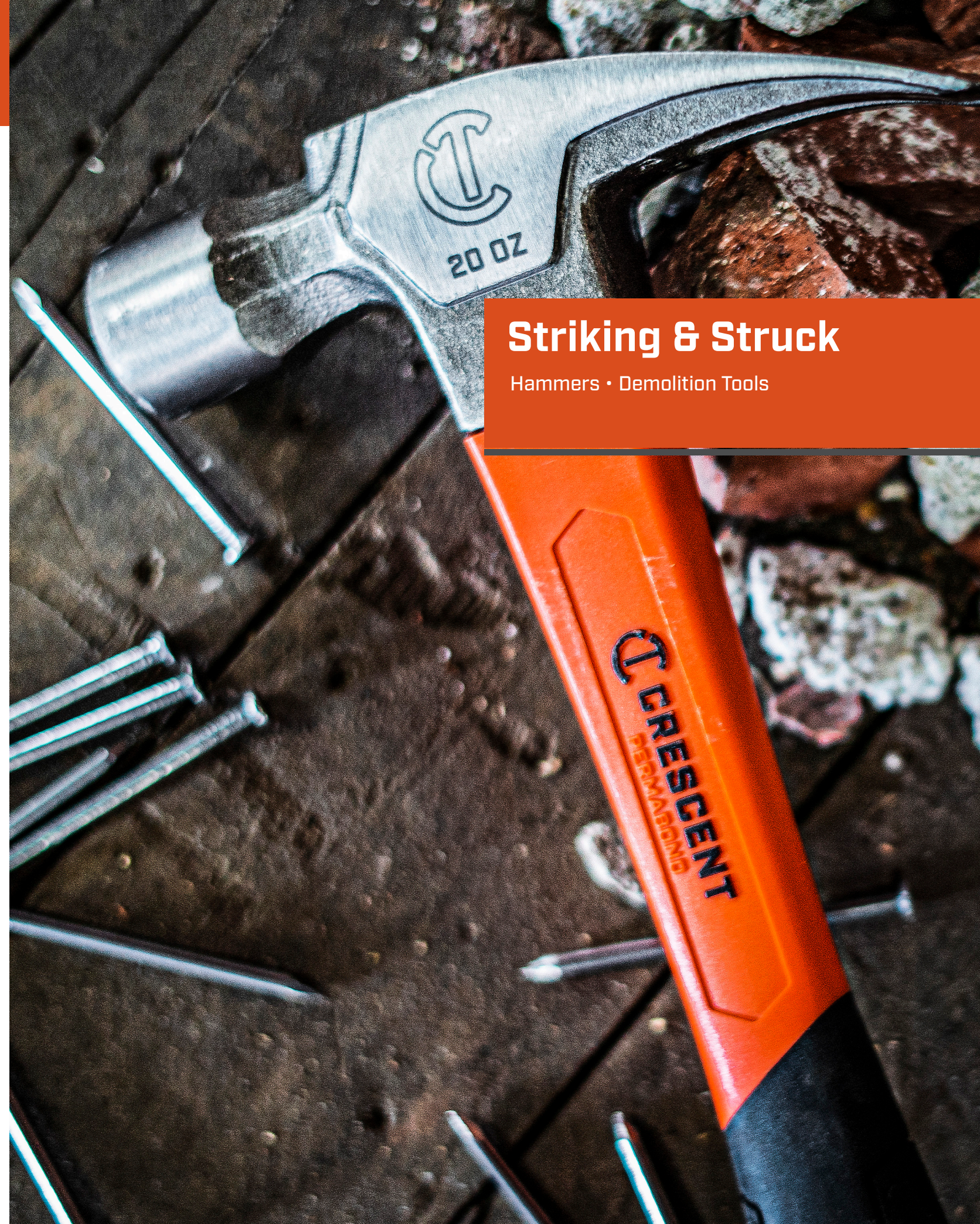

Striking & Struck

Hammers • Demolition Tools

Claw Hammers with Fiberglass Handles

- Maximum-strength head and claw forged of carbon steel, finished with a corrosion and rust resistant clear coat
- Contoured handle to increase comfort and reduce fatigue
- Solid fiberglass handle covered with a molded nylon jacket
- Comfortable cushion-grip handle with an enlarged base for butting materials
- PermaBond® construction securely attaches the head to the handle
- Extended steel throat prevents breakage due to overstrike
- Factory balanced for maximum striking power and control
- Convenient magnetic nail starter
- Rip claws designed to pull nails efficiently



Cat. No.	Head Weight (Oz.)	Head Length	Face Diameter	Face Finish	Handle Length	Overall Length	Product Weight
11419C	16 oz	5.41 in	1.16 in	Polished	5.5 in	13 in	1.200 lb
11418C	20 oz	5.78 in	1.21 in	Polished	5.5 in	13 in	1.750 lb

Indexing Claw Hammer with Steel Handle

- Extra-large smooth striking face provides solid contact when driving nails or persuading boards/materials
- Four unique positions for accessing and prying nails and boards with increased leverage
- Magnetic nail starter holds nails securely under the hammer head for quick and easy one hand nail starting
- Handle and claw are forged of carbon steel for maximum strength and finished with clear coat to prevent corrosion and rust
- TPR grip lets user comfortably apply more force when prying and prevents slippage when swinging with force



Cat. No.	Head Weight (Oz.)	Head Length	Face Diameter	Face Finish	Handle Length	Overall Length	Product Weight
CINDEX18	18 oz	5.25 in	1.18 in	Polished	7 in	14 in	2.110 lb

DIYers and tradesmen alike can count on the Dual Claw Wrecking Bar for every home renovation project.



Increased Leverage
Less effort and faster action



Dual Claw Design
Position tool on joist and forks pry up with even pressure on both sides to quickly remove boards

Deep Central Nail Puller
Quickly removes stubborn nails

Gripping Teeth
Assist in preventing board slippage

Rugged Indexing Joint
Allows for 180-degree flexibility and increased leverage



Bull Bar Indexing Decking Removal Tool

- Double fork design provides balanced lift on both sides of the nail for faster, cleaner, lower-effort board removal
- Rugged indexing joint allows for maximum flexibility and increased leverage
- Precision tips designed for fast access between boards and reduced damage for reclaiming materials
- Gripping teeth on forks assist in preventing board slippage
- Patent-pending center nail puller allows better balance and more leverage



Cat. No.	Tip Length	Tip Width	Overall Length	Product Weight
DKB446X	4.528 in	5.5 in	44 in	7.650 lb

Code Red™ Indexing Flat Renovation Bars

- Head indexes through an arc of over 180° and locks in 15 positions for maximum access
- Angled head with nail slot for prying and pulling nails or boards
- Extra-wide prying end prevents damage by spreading the prying force
- Raised heavy-duty striking surface on the head to assist in demolition
- Solid construction withstands wear, pressure, and damage
- Full steel body for increased durability and longer product life
- Heat-treated striking face
- Durable two-tone grip provides comfort, control, and slip prevention
- Always wear protective gear during use



Cat. No.	Tip Length	Tip Width	Overall Length	Product Weight
DB18X	3.74 in	2.17 in	18 in	2.635 lb
DB30X	3.74 in	2.17 in	30 in	4.100 lb

Code Red™ Adjustable Pry Bars

- Adjustable jaws slide and clamp to fit onto objects for straightening and prying
- Large claw on head adjusts for best leverage when pulling nails
- Crow bar end with nail puller slot
- Hammer head surface for striking



Cat. No.	Tip Length	Tip Width	Overall Length	Product Weight
DB16	5 in	1.73 in	16 in	3.68 lb
DB24	5 in	1.73 in	24 in	4.43 lb

Code Red™ Flat Pry Bars

- Precision ground ends for nail pulling with less material damage
- Nail slots in end and center for better access when pulling nails
- Radius end design adds strength and provides better prying leverage
- Durable high visibility red finish
- Finish is corrosion-resistant



Cat. No.	Tip Length	Tip Width	Overall Length	Product Weight
FB7	2.008 in	0.925 in	7 in	0.27 lb
FB13	3.858 in	1.909 in	13 in	1.46 lb
FB15	3.701 in	1.913 in	15 in	1.59 lb

Code Red™ Molding Bars

- Precision ground ends for nail pulling with less material damage
- Nail slots in both claw and pry ends for better access when pulling nails
- Striking face has ground surface for precision nailing
- Durable high visibility red finish
- Finish is corrosion-resistant



Cat. No.	Tip Length	Tip Width	Overall Length	Product Weight
MB8	2.12 in	.645 in	8 in	0.50 lb
MB10	2.48 in	.708 in	10 in	0.76 lb
MB12	2.48 in	.724 in	12 in	0.80 lb

Code Red™ Nail Pulling Pliers

- Excellent for removing damaged nails and fasteners
- Roll bar allows you to pull nails with a smooth, low-effort action
- Easily extract nails, regardless of their size
- Functionality of the pliers allows you to remove nails from the front or the back
- Plier teeth designed for an optimal grip on varied types of nails
- Dual handles make it quick and easy to grip, roll, and remove nails or staples
- Durable forged steel construction with rubber grips for comfort and control
- Black-oxide finish resists corrosion
- Dipped grips wipe clean easily



Cat. No.	Tip Length	Tip Width	Overall Length	Product Weight
NP11	.709 in	3.217 in	11 in	1.5 lb

Nail Puller

- Forged alloy box-joint and hardened, tempered jaw
- Black enamel finish offers extra durability
- Works great on flush, hard-to-grip nails
- Ideal for remodeling or renovation projects
- 16 penny nail jaw capacity
- 19" length and 24" full extension
- Meets or exceeds U.S. Federal Spec. GGG-P-79Lb, Type 1, Class-1



Cat. No.	Tip Length	Tip Width	Cont. Length	Ext. Length	Product Weight
56	1.1 in	.24 in	19 in	24 in	4.20 lb

Indexing Nail Puller

- Indexing head with 14 locking positions for quick angle adjustment up to 180 degrees for optimized leverage
- Striking face allows for claw to be driven under nails that are under the surface
- Designed to reach between studs, joists, and other obstructions
- Ergonomic, contoured handle for superior grip and user safety
- Exceeds ASME standards for strength; joint tested up to 10,000 lbs. of force



Cat. No.	Tip Length	Tip Width	Overall Length	Product Weight
DB12NP	2.657 in	.906 in	12.598 in	1.130 lb



Trade Tools

Work Gloves • Crimpers • Notchers
Seamers • Pipe Cutters • Molding Snips

Durahide™ Construction Gloves

Crescent has partnered with Mechanix Wear to provide work gloves with maximum durability and hand protection for professional tradespeople. Made with Durahide high-performance leather palms and rugged canvas backs, these gloves offer exceptionally long life and high abrasion resistance. Anatomically-shaped thermoplastic rubber (TPR) ribs protect knuckles and fingers from impact while EVA foam palm padding provides superior comfort.



Durahide™
Performance leather palm provides best-in-class abrasion resistance

Extended Cuff
Hook and loop wrist closure for a secure fit

Durahide™ Thumb Saddle Reinforcement

Rugged Canvas
Back-of-hand construction

EVA Foam
Internal palm padding for comfort

Thermoplastic Rubber (TPR) Ribs
Protect knuckles and fingers from impact



Mixed-Size Counter Display

Heavy Impact Work Gloves

- Durahide™ high abrasion leather and thumb reinforcement
- Thermoplastic rubber (TPR) impact protection
- CW level 4 abrasion rating
- Microfiber sweat wipe on back of thumb
- Internal EVA foam palm padding
- Rugged canvas back
- Extended cuff
- Hook and loop closure
- Machine washable
- 90 day limited warranty



Cat. No.	Gender	Size	Machine Washable	Waterproof	Description	Product Weight
CWGEMD	Unisex	M	Yes	Yes	Heavy Impact Work Gloves - Medium	0.350 lb
CWGLRG	Unisex	L	Yes	Yes	Heavy Impact Work Gloves - Large	0.360 lb
CWGXLG	Unisex	XL	Yes	Yes	Heavy Impact Work Gloves - Extra Large	0.380 lb

3-Blade Crimper

- Crimps male fitting end to connect guttering, downspouts, or metal pipe
- Optimal handle span for maximum power and comfortable operating range
- Ergonomic, single material non-slip handle grips provide excellent control and easy cleaning with built-in hang hole for convenient storage
- Handle latch keeps blades closed during storage or when not in use
- Compound action jaw provides excellent comfort and control



Cat. No.	Handle Color	Number of Blades	Throat Depth	Product Weight
WC3SN	Rawhide	3	1.25 in	0.85 lb

5-Blade Crimper

- Crimps male fitting end to connect guttering, downspouts, or metal pipe
- Optimal handle span for maximum power and comfortable operating range
- Ergonomic, single material non-slip handle grips provide excellent control and easy cleaning with built-in hang hole for convenient storage
- Handle latch keeps blades closed during storage or when not in use
- Compound action jaw provides excellent comfort and control



Cat. No.	Handle Color	Number of Blades	Throat Depth	Product Weight
WC5SN	Rawhide	5	1.25 in	0.95 lb
WC5LN	Rawhide	5	1.625 in	1.00 lb

Hand Notcher

- Cuts 30-degree V-shaped notch in sheet metal
- Produces a clean notch without slipping at corners or take-off tabs
- Ergonomic, single material non-slip handle grips provide excellent control and easy cleaning with built-in hang hole for convenient storage
- Handle latch keeps blades closed during storage or when not in use



Cat. No.	Handle Color	Throat Depth	Product Weight
WHN1N	Rawhide	.812 in	0.95 lb

Cable Tie Tensioning Tool

- Designed to install both heavy and light duty nylon cable ties
- For tightening nylon ties when securing flex duct to take-off collars
- Easy-to-operate cut-off mechanism that trims excess cable strap
- Ergonomic, single material non-slip handle grips provide excellent control and easy cleaning



Cat. No.	Handle Color	Cable Tie Width	Product Weight
WT1	Rawhide	.375" and Thinner	0.90 lb

Hand Seamer

- Used for bending and flattening sheet metal
- Optimal handle span for maximum power and comfortable operating range
- Ergonomic, single material non-slip handle grips provide excellent control and easy cleaning with built-in hang hole for convenient storage
- Handle latch keeps blades closed during storage or when not in use
- 1/4" depth markings
- Produces a permanent, tight-fitting seam



Cat. No.	Handle Color	Jaw Capacity	Throat Depth	Jaw Width	Product Weight
WS3N	Rawhide	.25 in - 1.25 in	1.25 in	3.25 in	1.35 lb
WS6N	Rawhide	.25 in - 1.25 in	1.25 in	6 in	1.90 lb

Folding Tools

- Commonly used for folding channels and making long uniform bends in sheet metal
- Ideal for folding drive cleat channels with 3/8" depth to make longer wider folds in register boots, end caps, plenums, etc...
- Constructed of heavy 16 gauge steel that keeps folding channels from widening and ensures precise and accurate bends
- 3/8" and 1" depth folding channel to ensure proper depth alignment



Cat. No.	Overall Length	Folding Channel Depths	Product Weight
WF12	12 in	.375 in & 1 in	1.30 lb
WF18	18 in	.375 in & 1 in	2.00 lb
WF24	24 in	.375 in & 1 in	2.70 lb

Offset Hand Seamer

- Used for bending and flattening sheet metal
- Ideal for working in confined areas
- Optimal handle span for maximum power and comfortable operating range
- Ergonomic, single material non-slip handle grips provide excellent control and easy cleaning with built-in hang hole for convenient storage
- Handle latch keeps blades closed during storage or when not in use
- 1/4" depth markings
- Produces a permanent, tight-fitting seam



Cat. No.	Handle Color	Throat Depth	Jaw Width	Jaw Capacity	Product Weight
WS4N	Rawhide	1.25 in	3.25 in	.25 in - 1.25 in	1.40 lb

Ratcheting Pipe Cutters

- Cuts copper, brass, aluminum, and thin-wall conduit material
- Made from high-carbon chrome steel
- Includes 2 interchangeable wheels for added convenience
- Easily replaceable cutting wheel installs with a small standard screwdriver



Cat. No.	Cutting Capacity	Product Weight
WRPCLG	.312 in - 1.125 in	0.77 lb

Molding Miter Snips

- Perfect for cutting all types of small molding in PVC, MDF, and pine
- Built-in angle finder for convenience and accuracy
- Saves time by avoiding changing angles on a saw, no need for electricity
- Blade is able to be sharpened for prolonged use
- Single material, dipped grips for easy cleaning and better control
- Durable steel construction



Cat. No.	Handed	Overall Length	Cutter Head / Blades	Blade Length	Cutting Capacity	Product Weight
M45RS	Both	8.5 in	Hardened Steel Cutter	3.5 in	PVC, MDF and Pine	1.050 lb

Siding Removal Tool

- Innovative dual material handle for comfort and performance
- Includes reverse and offset scrapers
- Oil and solvent resistant



Cat. No.	Overall Length	Product Weight
WSR1N	9 in	0.20 lb

Snap Lock Punch

- Forms tabs to secure vinyl siding or plastic skirting to finishing trim
- 3/8" throat
- Vinyl handle grips for added comfort



Cat. No.	Overall Length	Product Weight
WSP1	11 in	0.70 lb

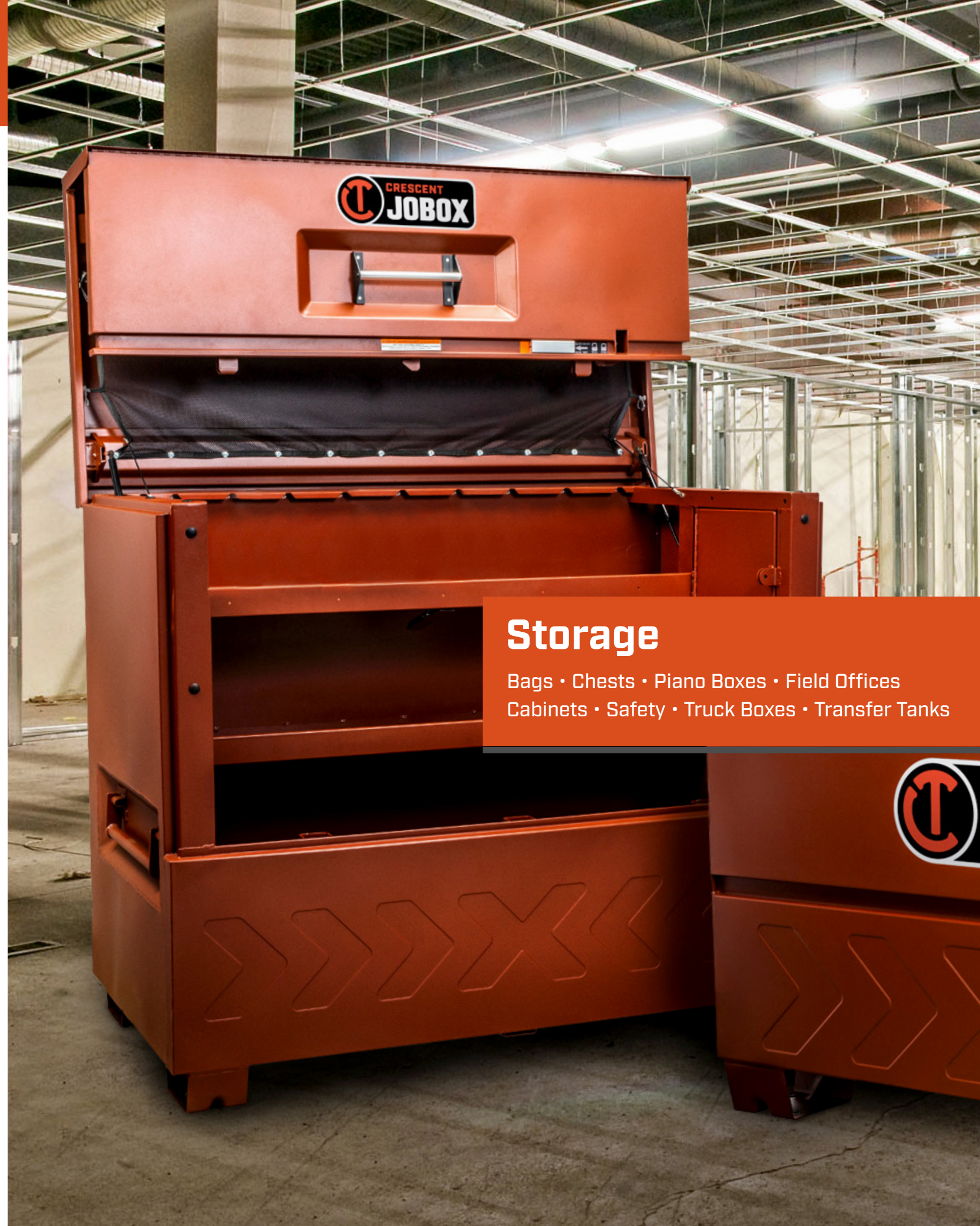

Storage

Bags • Chests • Piano Boxes • Field Offices
Cabinets • Safety • Truck Boxes • Transfer Tanks

Crescent Tradesman Tool Bags

Introducing the new line of Crescent Tool Bags. Made for strength. Made to last. Made for the long haul. Superior tool organization combined with the quickest and easiest access. These bags are made to take the drops, drags, hits and misses that are just part of life on every jobsite.

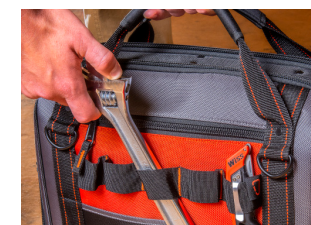

On Closed-Style Bags:
PALS-Style Webbing Allows fast and easy access to frequently used tools

Tradesman Closed Top Tool Bags

- Professional grade closed top bag is ideal for everyday use in rugged conditions
- 3 exterior pockets and a 29-pocket interior tool wall provide additional organization
- Hard polypropylene base resists moisture and withstands impacts, delivering lasting durability
- Bright orange interior helps you find your tools faster in darker environments
- Made with 1680D polyester and metal hardware to hold up on the toughest jobsite
- 13 PALS-style loops on the outside of the bag provide quick, easy access to your frequently used tools
- Inner sleeves are open at the bottom so small items won't get lost deep in narrow pockets
- Adjustable, padded shoulder strap and padded nonslip bar handle make carrying the bag more comfortable
- Includes a water bottle holder and a tape measure clip for added convenience
- Top-quality YKK zipper comes with a 3-year warranty and an oversized pull for added convenience



Cat. No.	Depth	Width	Height	Inside Length	Inside Width	Inside Height	Product Weight
CTB1450	14 in	9.2 in	14.5 in	13.75 in	7.75 in	10.75 in	5.220 lb
CTB1750	17 in	9.5 in	16.7 in	16.75 in	8.75 in	11.75 in	6.550 lb

Tradesman Open Top Tool Bags

- Professional grade open top bag is ideal for everyday use in rugged conditions
- 17 interior and 8 exterior pockets line the bag, so you can keep your equipment in order
- Hard polypropylene base resists moisture and withstands impacts, delivering lasting durability
- Bright orange interior helps you find your tools faster in darker environments
- Made with 1680D polyester and metal hardware to hold up on the toughest jobsite
- 2 exterior pocket sleeves for small parts such as sockets or screws
- Center metal handle meets durability standards and provides comfort while carrying the bag from job to job
- Adjustable, padded shoulder strap and padded nonslip bar handle make carrying the bag more comfortable
- Top-quality YKK zipper comes with a 3-year warranty and an oversized pull for added convenience



Cat. No.	Depth	Width	Height	Inside Length	Inside Width	Inside Height	Product Weight
CTB1410	14 in	9.6 in	14.5 in	13.75 in	7.75 in	9.25 in	5.510 lb
CTB1710	17 in	11 in	16 in	16.5 in	8.75 in	11 in	7.050 lb

20" Contractor Tool Bag

- Professional grade contractor bulk bag is perfect for everyday use in rugged conditions
- 11 exterior and 19 interior pockets provide a variety of storage and organization options for materials, tools and small parts
- Hard polypropylene base resists moisture and protects the bag from wear and tear in tough environments
- Bright orange interior helps you find your tools faster in darker environments
- Made with 1680D polyester and metal hardware to hold up on the toughest jobsite
- 13 PALS-style loops on the outside of the bag provide quick, easy access to your frequently used tools
- Two padded handles make carrying the bag more comfortable and distribute the bag's weight for added durability
- Padded shoulder strap provides convenient, hands-free transportation
- Top-quality YKK zipper comes with a 3-year warranty and an oversized pull for added convenience



Cat. No.	Depth	Width	Height	Inside Length	Inside Width	Inside Height	Product Weight
CTB2010	20 in	12.2 in	13 in	19.75 in	10.75 in	13.75 in	4.870 lb

Tradesman Rolling Tool Bag

- Professional grade rolling bag is ideal for everyday use in rugged conditions
- 200-lb lid capacity allows you to carry all your tool bags together
- 2-way magnetic lid
- Bright orange interior helps you find your tools faster in darker environments
- 1680 denier ballistic weave material for rugged durability
- Ergonomically designed top handle and telescoping pull handle for comfort and easy mobility
- 35 total pockets for ultimate tool storage capability
- 17 interior and 8 exterior pockets line the bag, so you can keep your equipment in order



Cat. No.	Depth	Width	Height	Inside Length	Inside Width	Inside Height	Product Weight
CTBR1850	20 in	13 in	18 in	16.5 in	9.75 in	15.5 in	15.590 lb

Tradesman Steel Chests

- High-security design features enclosed dual lock system that resists saws, pry bars, and bolt cutters
- Grip-Rite™ lifting channel provides better grip on lid for easier and safer lid operation
- Rain-Drain feature in padlock housing prevents water from collecting in box
- Ergonomic lifting handles are positioned inside deep recesses to prevent pinched knuckles and damage to handles
- EZ-Loader 4-way skid bolsters allow forklift loading from any side for quicker and easier transport
- Skid bolsters are compatible with casters (Part #1-320993, not included) for easy mobility
- Heavy-duty hinge is staked and welded to prevent the pin from being forced out for break in



Cat. No.	Length	Width	Height	Inside Length	Inside Width	Inside Height	Usable Cu. Ft.	App. Ship Wt.
CJB635990	36 in	19.5 in	22 in	34 in	18.5 in	18.5 in	8.9 ft³	88 lb
CJB636990	42 in	20 in	22 in	40 in	19 in	19 in	10.7 ft³	101 lb
CJB637990	48 in	24 in	27.5 in	46 in	23 in	24 in	18.3 ft³	140.5 lb
CJB638990	60 in	24 in	27.5 in	58 in	23 in	24 in	22.9 ft³	155 lb

Tradesman Backpack

- Professional grade backpack is ideal for everyday use, with an adjustable front pocket to hold large items like electrical cords
- 4 exterior pockets and 34 interior pockets for all parts as well as exterior pockets for the frequently used tools
- Hard polypropylene base is moisture resistant and stands up to tough environments for long-lasting durability
- Bright orange interior helps you find your tools faster in darker environments
- Made with 1680D polyester and metal hardware to hold up on the toughest jobsite
- Inner sleeves are open at the bottom so small items won't get lost deep in narrow pockets
- Specialized magnetic pocket stores items for quick access
- Ergonomic handle is easy to grab and provides a comfortable, nonslip grip
- Includes a water bottle holder and a tape measure clip for added convenience
- Top-quality YKK zipper comes with a 3-year warranty and an oversized pull for added convenience



Cat. No.	Depth	Width	Height	Inside Length	Inside Width	Inside Height	Product Weight
CTB1000	14 in	10 in	18 in	12.75 in	7.5 in	16.5 in	8.000 lb



Crescent JOBBOX Tradesman Steel Chests

Tradesman Steel Chests provide rugged, dependable, and secure on-site storage in commercial, industrial, and construction environments. Staked and welded hinges and a dual enclosed lock system provide maximum security that is highly resistant to saws, pry bars, and bolt cutters. Gas spring lid control and the exclusive Crescent JOBBOX Grip-Rite™ lifting channel provide easy and safe lid operation. Tradesman Steel Chests offer the perfect combination of security, durability, and utility required by trade professionals.

**Grip-Rite™
Lifting Channel**
Better grip on lid for easier and safer lid operation



Lid Control Gas Spring

Eases lifting and prevents lid from slamming shut

Ergonomic Lifting Handles

Recessed to prevent pinched fingers and damage to the handle

EZ-Loader 4-Way Skid Bolsters

Allow fork lift loading from any side for quicker and easier transport

Lock System Rain Drain
Protects lock and box contents from moisture

Dual Enclosed Lock System
High-security design resists saws, pry bars, and bolt cutters



Crescent JOBBOX Site-Vault™ Heavy-Duty Chests

Designed for security, easy access and excellent weather resistance, the Crescent JOBBOX Chest yields an abundance of features including four-way skid bolsters, and a visual, three-point locking system.

Site-Vault® Security System

The patented system has a full-length steel lock console with three locking points and fluorescent reflective orange tape that indicates chest is locked

More Padlock Compatibility

Use Master #1, #5, #175, and American 50

Reinforced Lid with Full-Length Bolster

Reduces damage from excess stacking weight and resists pry bar entry

EZ-Lock Arm

Securely locks lid open

Dual Built-In Lid Storage Bins

Cargo nets hold items like first aid kit, manuals, rain gear and safety items

Recessed Handles

Prevent pinched fingers and damage to the handle

Integrated Sidewall Cargo Bin

Convenient storage for small tools and parts



EZ-Loader 4-Way Skid Bolsters

Allow fork lift loading from any side for quicker and easier transport

Site-Vault™ Heavy-Duty Chests

- Site-Vault™ security system is a patented system with 3 locking points and a reflective orange lock indicator that shows when the box is locked or unlocked
- Heavy-duty beveled edge lid eliminates sharp front lid corners and enhances lid strength
- Dual built-in lid storage with integrated cargo nets is perfect for rain gear, PPE or small tools
- EZ-Lock support arm secures and locks lid in open position for safe use
- Upgraded lock system now allows usage of padlock models Master #1, #5, #175 and American #50
- Integrated sidewall cargo bin provides convenient storage for small tools and parts
- Ergonomic lifting handles are positioned inside deep recesses to prevent pinched knuckles and damage to handles
- Heavy-duty EZ-Loader 4-way skid bolsters allow fork lift loading from any side for quicker and easier transport
- Skid bolsters are compatible with casters (Part #1-320993, not included) for easy mobility
- Heavy-duty hinge is staked and welded to prevent the pin from being forced out for break in



Cat. No.	Length	Width	Height	Inside Length	Inside Width	Inside Height	Usable Cu. Ft.	App. Ship Wt.
2-651990	30 in	20 in	19.75 in	28 in	19 in	16.2 in	5 ft³	60 lb
2-652990	36 in	20 in	27.5 in	34 in	19 in	24 in	9 ft³	98 lb
2-653990	42 in	20 in	27.5 in	40 in	19 in	24 in	10.5 ft³	118 lb
2-654990	48 in	24 in	30.75 in	46 in	23 in	27.2 in	16.7 ft³	148 lb
2-656990	48 in	30 in	36.75 in	46 in	29 in	33.2 in	25.6 ft³	190 lb
2-655990	60 in	24 in	30.75 in	58 in	23 in	27.2 in	21 ft³	182 lb
2-658990	72 in	24 in	30.75 in	70 in	23 in	27.2 in	25.3 ft³	203 lb

Embedded Lock Small Chest

- Bolt cutter-proof lock housing
- Compact and portable
- Staked and welded hinges
- Welded corner gussets
- Heavy-duty lifting handles
- Bottom bolsters for lift and support
- 10-gauge latching hasp



Cat. No.	Length	Width	Height	Inside Length	Inside Width	Inside Height	Usable Cu. Ft.	App. Ship Wt.
651990D	31 in	18 in	15.5 in	28.48 in	12.75 in	11.95 in	4 ft³	70 lb

Site-Vault™ Heavy Duty Chests with Drawer

- Site-Vault™ security system is a patented system with 3 locking points and a reflective orange lock indicator that shows when the box is locked or unlocked
- Heavy-duty beveled edge lid eliminates sharp front lid corners and enhances lid strength
- EZ-Lock support arm secures and locks lid in open position for safe use
- Upgraded lock system now allows usage of padlock models Master #1, #5, #175 and American #50
- Drawer storage with up to 500lb capacity to meet all your equipment needs and keep your box organized
- Ergonomic lifting handles are positioned inside deep recesses to prevent pinched knuckles and damage to handles
- Heavy-duty EZ-Loader 4-way skid bolsters allow fork lift loading from any side for quicker and easier transport
- Skid bolsters are compatible with casters (Part #1-320993, not included) for easy mobility
- Heavy-duty hinge is staked and welded to prevent the pin from being forced out for break in



Cat. No.	Length	Width	Height	Inside Length	Inside Width	Inside Height	Usable Cu. Ft.	App. Ship Wt.
2D-656990	48 in	30 in	36.625 in	44.5 in	29.875 in	14.625 in	20 ft³	200 lb
2DL-656990	48 in	30 in	36.625 in	44.5 in	29.875 in	14.625 in	20 ft³	225 lb

Welder's Box

- Cut-out for supply hose
- Compact and portable
- Staked and welded hinges
- Welded corner gussets
- 10-gauge latching hasp
- Wide lifting handles
- Textured powder paint finish



Cat. No.	Length	Width	Height	Inside Length	Inside Width	Inside Height	Usable Cu. Ft.	App. Ship Wt.
650990D	30 in	16 in	12 in	29 in	15.45 in	11.84 in	3.3 ft³	33 lb

Slope Lid Chest

- Site-Vault™ security system with bolt-cutter proof housing
- Full-length steel lock console with three locking points
- Fully welded padlock housing
- Lid support rod props up lid for a flat working surface
- Grip-Rite™ lifting channel for easier opening
- Full-length A-frame lid bolster
- 1" locking arms
- Staked and welded hinge
- Lift-N-Stow hinged shelf to store bulky items in the bottom
- Recessed handles



Cat. No.	Length	Width	Height	Inside Length	Inside Width	Inside Height	Usable Cu. Ft.	App. Ship Wt.
1-680990	60 in	30 in	39.5 in	57.5 in	19.4 in	Bottom to Shelf 19.4 in Shelf to Top 13 in	32.7 ft³	243 lb

High-Capacity Drop-Front Chest

- Site-Vault™ security system with bolt-cutter proof housing
- Full-length steel lock console with two locking points
- Fully welded padlock housing
- Grip-Rite™ lifting channel for easier opening
- Full-length A-frame lid bolster
- Staked and welded hinge
- 1" locking arm
- Power cord access hole
- Recessed handles
- Lid lowering assist shock absorber



Cat. No.	Length	Width	Height	Inside Length	Inside Width	Inside Height	Usable Cu. Ft.	App. Ship Wt.
1-657990	60 in	31 in	45 in	57.5 in	27.5 in	39 in	41.5 ft³	340 lb

Crescent JOBBOX Piano Boxes

The perfect combination of storage space, organization, and security, the world renowned Crescent JOBBOX Piano Box is a job site must-have. Two storage bins on both side walls and the Crescent JOBBOX Lift-N-Stow Shelf give you room to store any item, while the Site-Vault™ security system ensures that your valuables remain safe and secure.



Site-Vault® Security System
The patented system has a full-length steel lock console with three locking points and fluorescent reflective tape that indicates chest is unlocked

Built-In Lid Storage
Easy access for hanging harnesses

Top Shelf
Designed for 1,000 lb. capacity to hold chain hoists

Full-Width Shelf
With 500 lb. capacity

Recessed Handles
Prevent pinched fingers and damage to the handle

Side Wall Storage
With padlock-able box for personal items



Lift-N-Stow™ Shelf
Swings up to accommodate large items

Low Height Front Panel
For easier loading and unloading of equipment

Site-Vault™ Heavy-Duty Piano Boxes

- Site-Vault™ is a patented security system with 3 locking points and a reflective orange lock indicator that shows when the box is locked or unlocked
- Heavy-duty beveled edge lid eliminates sharp front lid corners and enhances lid strength
- Built-in door storage with hooks and cargo nets for storing harnesses, rain gear, jackets, etc...
- Upgraded lock system now allows usage of padlock models Master #1, #5, #175 and American #50
- Integrated sidewall storage locker can be padlocked for personal items
- Ergonomic lifting handles are positioned inside deep recesses to prevent pinched knuckles and damage to handles
- Heavy-duty EZ-Loader 4-way skid bolsters allow fork lift loading from any side for quicker and easier transport
- Skid bolsters are compatible with casters (Part #1-320993, not included) for easy mobility
- High-strength top shelf is rated to hold 1,000 pounds
- Rigid 4" formed sidewalls resist wind-driven rain and pry bar break-in for long term durability and equipment protection



Site-Vault™ Heavy-Duty Piano Boxes with Drawer

- Site-Vault™ is a patented security system with 3 locking points and a reflective orange lock indicator that shows when the box is locked or unlocked
- Heavy-duty beveled edge lid eliminates sharp front lid corners and enhances lid strength
- Built-in door storage with hooks and cargo nets for storing harnesses, rain gear, jackets, etc...
- Integrated sidewall storage locker can be padlocked for personal items
- Drawer capacity of up to 500lb- keeping your equipment locked and organized
- Lift-N-Stow™ Bottom Shelf lifts up for easy loading & is rated to support up to 500lbs, High-Strength Top Shelf is Rated to Hold 1,000 lbs
- Rigid 4" Formed Sidewalls resist wind driven rain and pry bars for long term durability and equipment protection
- Short formed lower front panel is stronger and allows easier loading and unloading
- 3 Built-in sidewall bins for convenient access and organized storage
- Improved gas spring mounts allow easier door opening



Cat. No.	Length	Width	Height	Inside Length	Inside Width	Inside Height	Drop Front	Usable Cu. Ft.	App. Ship Wt.
2D-681990	48 in	31.15 in	56.78 in	47.875 in	28.875 in	37.75 in	No	44.45 ft³	450 lb
2D-682990	60 in	30.75 in	56.78 in	59.875 in	28.875 in	37.75 in	No	20 ft³	580 lb

Cat. No.	Length	Width	Height	Inside Length	Inside Width	Inside Height	Drop Front	Usable Cu. Ft.	App. Ship Wt.
2-681990-01	47.9 in	31 in	51 in	47.9 in	29.9 in	47.2 in	No	39.1 ft³	298 lb
2-682990-01	60 in	31 in	51 in	59.9 in	29.9 in	47.2 in	No	48.9 ft³	354.000 lb
2-688990-01	60 in	31 in	39 in	60 in	29.9 in	35.2 in	No	36.5 ft³	279.000 lb
2-689990-01	74 in	31 in	51 in	59.9 in	29.9 in	47.2 in	No	60. ft³	413.000 lb
2-683990-01	60 in	31 in	51 in	59.9 in	29.9 in	47.2 in	Yes	48.9 ft³	380.000 lb
2-684990-01	74 in	31 in	51 in	73.9 in	29.9 in	47.2 in	Yes	60.3 ft³	437.500 lb
2-685990-01	74 in	35 in	64 in	74 in	34 in	60.2 in	No	87.4 ft³	520.000 lb

Field Office

- Large lockable desktop can be raised to make a flat working surface
- Beveled sidewalls for enhanced weather resistance and security
- Steel pegboard
- 30 cubic foot storage locker
- Rain gutters
- Upper door safety bar support with locking pin
- Stainless steel door hinges resist rust
- EZ-Loader® skid bolsters
- One handle lock
- Storage area for plans and binders on side wall



Cat. No.	Length	Width	Height	Storage Cap. Upper	Storage Cap. Lower	Usable Cu. Ft.	App. Ship Wt.
1-674990	63 in	42 in	80 in	60.6 ft³	9.4 ft³	100 ft³	660 lb

Heavy-Duty Piano Box

- Two gas springs assist with opening and closing the door
- Ergonomic lifting handles are positioned inside deep recesses to prevent pinched knuckles and damage to handles
- Tall bottom bolsters for easily moving a loaded piano box with a forklift
- Rain-Drain feature in padlock housing prevents water from collecting in box
- High-security design features enclosed dual lock system that resists saws, pry bars, and bolt cutters



Cat. No.	Length	Width	Height	Inside Length	Inside Width	Inside Height	Usable Cu. Ft.	App. Ship Wt.
640990	60 in	30.5 in	49.88 in	56.5 in	28.5 in	45.3 in	48 ft³	308 lb

Mobile Field Office

- Full size desk, easily handles size "E" prints
- 11 built-in bins for organization while on the job
- Removable upper shelf opens the rear wall to add a monitor
- Extreme mobility for convenience on the job; roll it (through 36" doors), telehandle it, or hoist it
- Perfect desk height for comfort while working
- Slide-out bottom shelf for easy access to items



Cat. No.	Length	Width	Height	Storage Cap. Upper	Storage Cap. Lower	Usable Cu. Ft.	App. Ship Wt.
1-510990	63 in	33 in	80 in	46.5 ft ³	24.69 ft ³	61 ft ³	581 lb

Mesh Cabinets

- Removable shelves can be adjusted to multiple positions for maximum storage flexibility
- Sliding shelves provide easy access even when loaded to the maximum capacity of 200 lbs
- Built-in door shelves provide convenient highly visible storage
- Solid top and bottom construction to prevent items from falling through mesh
- Flat bottom shelf with no lip allows easy loading and unloading of heavy items
- White shelving provides high visibility in the cabinet
- Rugged 3 point locking system and continuous door hinges provide long term durability
- Conveniently fits through a standard 3' commercial doorway
- Push handle and shelf provide convenient storage for a step ladder, shelf can hold up to 200 lbs



Cat. No.	Length	Width	Height	Inside Length	Inside Width	Inside Height	Usable Cu. Ft.	App. Ship Wt.
1-402990	42.5 in	33 in	51.25 in	41.75 in	50.75 in	32.625 in	40 ft ³	215 lb
1-401990	59.25 in	33 in	55 in	58.625 in	54.625 in	32.625 in	60.46 ft ³	328 lb
1-403990	75 in	33 in	55 in	74.625 in	54.625 in	32.625 in	76.96 ft ³	368 lb
1-400990	75 in	33 in	55 in	74.625 in	54.625 in	32.625 in	76.96 ft ³	375 lb

Tradesman Field Office

- Large lockable desktop can be raised to make a flat working surface
- Built-in sidewall bins
- Upper door safety bar support with locking pin
- Full 42" deep bottom shelf
- Full door weather stripping
- EZ-Loader[®] 4-way skid bolsters
- One handle lock
- Lid lowering assist shock absorber
- EZ-Loader[®] skid bolsters
- Formed-in reinforcements strengthen skid bolsters



Cat. No.	Length	Width	Height	Storage Cap. Upper	Storage Cap. Lower	Usable Cu. Ft.	App. Ship Wt.
1-669990	63 in	42 in	79 in	60.1 ft ³	39 ft ³	99.6 ft ³	604 lb

Heavy-Duty Cabinets

- Nearly 17 linear feet of door shelf storage
- Three 5/8" steel locking pins per door
- Welded corner gussets
- Three heavy-duty lock hooks per door
- EZ-Loader[®] skid bolsters
- Access holes for electrical cables
- Staked and welded hinge
- Stainless steel door hinges resist rust
- Hand or foot operated door latch release system
- Grip-Rite[™] lifting channel



Cat. No.	Description	Length	Width	Height	Usable Cu. Ft.	App. Ship Wt.
1-698990	Two Doors	60.125 in	30.25 in	60.75 in	58.7 ft ³	436 lb
1-694990	Two Doors	60.750 in	24.25 in	60.25 in	47.5 ft ³	379 lb
1-697990	Two Doors, Open Side	60.125 in	24.25 in	60.75 in	47.5 ft ³	366 lb
1-695990	Four Doors, Both Sides	60.125 in	32.25 in	60.75 in	63.7 ft ³	523 lb

Rolling Work Benches

- Fully adjustable interiors for maximum storage flexibility
- Heavy-duty 18-gauge steel drawers
- 75 lb. capacity drawers
- Ball bearing glides on drawers
- 4 heavy-duty casters; 2 fixed and 2 locking swivel
- Staked and welded hinge
- Welded corner gussets



Cat. No.	Description	Length	Width	Height	Usable Cu. Ft.	App. Ship Wt.
675990	2 Drawers, 2 Shelves, 4" Casters	43.375 in	26.875 in	38.5 in	21.7 ft³	267 lb
675996	2 Drawers, 2 Shelves, 6" Casters	43.375 in	26.875 in	40.5 in	21.7 ft³	280 lb
676990	4 Drawers, 1 Shelf, 4" Casters	43.375 in	26.875 in	38.5 in	21.7 ft³	294 lb
676996	4 Drawers, 1 Shelf, 6" Casters	43.375 in	26.875 in	40.5 in	21.7 ft³	307 lb
677990	Body with 6" Casters, Add Drawers & Shelves	49.375 in	26.875 in	40.625 in	24.6 ft³	264 lb
678990	6 Drawers, 1 Shelf, 6" Casters	49.375 in	26.875 in	40.625 in	24.6 ft³	342 lb

Rolling Clam Shell Cabinet

- Eight 4" heavy-duty casters open and close cabinet
- Hinge stop prevents cabinet from fully opening and reduces potential for tipping
- High center handles for opening, closing, and moving cabinet
- 10-gauge latching hasp
- Rugged 16-gauge steel construction
- Moveable top and bottom shelves
- Open storage closet for tall items
- Lockable storage locker inside cabinet
- Only key entry area of padlock is exposed



Cat. No.	Length	Width	Height	Inside Length	Inside Width	Inside Height	Usable Cu. Ft.	App. Ship Wt.
692990	62.25 in	30 in	63.5 in	60 in	15.75 in	57.772 in	58 ft³	472 lb

Extra-Heavy Duty Bin Cabinet

- Over 40' of shelving built into doors for holding smaller items
- Heavy-duty galvanized movable bin dividers
- Dividers can be moved in 2" increments or removed to create various size bins
- Divider assembly required
- Center EZ-Loader® skid bolster
- Formed-in reinforcements strengthen skid bolsters
- 7-gauge, one-piece steel bolsters with holes to install optional casters
- Access holes for electrical cables
- Staked and welded hinges
- Hand or foot operated door latch release system



Cat. No.	Length	Width	Height	Usable Cu. Ft.	App. Ship Wt.
1-693990	72 in	24 in	61 in	49 ft³	522 lb

Drawer Cabinet

- Drawers fully extend for easy access
- Hand or foot operated door latch release system
- Site-Vault™ security system
- Fully welded padlock housing
- EZ-Loader® skid bolsters
- Welded corner gussets
- Forklift accessible from all sides
- 4.5" deep top shelf and three 3" deep shelves on each door
- Recessed handles
- 2.5" drawers have 75-lb. load capacity and 5.5" drawers have 125-lb. load capacity.



Cat. No.	Length	Width	Height	Usable Cu. Ft.	App. Ship Wt.
1-679990	60.75 in	60.125 in	60.75 in	58.7 ft³	610 lb

Safety Cabinets

- UL certified; Crescent JOBBOX® safety cabinets are fully insulated to provide superior fire retardant performance and eliminate gaps or hot spots
- Crescent JOBBOX® 12-gauge steel EZ-Level™ skid bolsters come equipped with a leveling screw access hole to provide quick and easy access for leveling your cabinet
- Featuring EZ-Level™, our unique anti-tip design, which provides maximum stability and tipping resistance
- Highly visible safety and warning labels provide a permanent reminder and reference for following proper safety and usage practices
- Cabinets have a 3-point locking system, featuring a rugged lockable paddle handle to restrict access and reduce the potential for theft
- Tilted spill-guide interior shelving directs spills to the back of the cabinet and into the retention sump area for easy cleaning
- Bright white shelves makes it easier to identify spills
- High-quality powder paint finish has 10x the corrosion resistance, 5x the abrasion resistance, and 2x the chip and scratch resistance of liquid paint
- High and low vent connections



■ Use yellow Crescent JOBBOX® cabinets to store flammable liquids

Cat. No.	Capacity	Color	Length	Width	Height	Inside Length	Inside Width	Inside Height	Usable Cu. Ft.	App. Ship Wt.
1-750640	12 Gallons	Yellow	30.4 in	20.04 in	37.17 in	26.92 in	16.56 in	31.29 in	8.07 ft³	160 lb
1-753640	30 Gallons	Yellow	46.12 in	23.25 in	45.72 in	42.84 in	17.32 in	36.47 in	15.66 ft³	235 lb
1-756640	45 Gallons	Yellow	46.07 in	23.25 in	66.71 in	42.84 in	17.36 in	57.42 in	24.71 ft³	325 lb
1-758640	60 Gallons	Yellow	46.12 in	30.22 in	66.71 in	42.84 in	24.41 in	57.42 in	34.74 ft³	384 lb
1-759640	90 Gallons	Yellow	46.12 in	33.23 in	66.71 in	42.84 in	27.38 in	57.42 in	38.97 ft³	408 lb

■ Use red Crescent JOBBOX® cabinets to store paints, inks, and combustibles

Cat. No.	Capacity	Color	Length	Width	Height	Inside Length	Inside Width	Inside Height	Usable Cu. Ft.	App. Ship Wt.
1-750610	12 Gallons	Red	30.4 in	20.04 in	37.17 in	26.92 in	16.56 in	31.29 in	8.07 ft³	160 lb
1-753610	30 Gallons	Red	46.12 in	23.25 in	45.72 in	42.84 in	17.32 in	36.47 in	15.66 ft³	235 lb
1-756610	45 Gallons	Red	46.07 in	23.25 in	66.71 in	42.84 in	17.36 in	57.42 in	24.71 ft³	325 lb
1-758610	60 Gallons	Red	46.12 in	30.22 in	66.71 in	42.84 in	24.41 in	57.42 in	34.74 ft³	384 lb
1-759610	90 Gallons	Red	46.12 in	33.23 in	66.71 in	42.84 in	27.38 in	57.42 in	38.97 ft³	408 lb

■ Use green Crescent JOBBOX® cabinets to store pesticides and insecticides

Cat. No.	Capacity	Color	Length	Width	Height	Inside Length	Inside Width	Inside Height	Usable Cu. Ft.	App. Ship Wt.
1-750620	12 Gallons	Green	30.4 in	20.04 in	37.17 in	26.92 in	16.56 in	31.29 in	8.07 ft³	160 lb
1-753620	30 Gallons	Green	46.12 in	23.25 in	45.72 in	42.84 in	17.32 in	36.47 in	15.66 ft³	235 lb
1-756620	45 Gallons	Green	46.07 in	23.25 in	66.71 in	42.84 in	17.36 in	57.42 in	24.71 ft³	325 lb
1-758620	60 Gallons	Green	46.12 in	30.23 in	66.71 in	42.84 in	24.41 in	57.42 in	38.97 ft³	384 lb
1-759620	90 Gallons	Green	46.12 in	33.23 in	66.71 in	42.84 in	27.38 in	57.42 in	38.97 ft³	408 lb

Self Closing Safety Cabinets

- UL certified; Crescent JOBBOX® safety cabinets are fully insulated to provide superior fire retardant performance and eliminate gaps or hot spots
- Crescent JOBBOX® 12-gauge steel EZ-Level™ skid bolsters come equipped with a leveling screw access hole to provide quick and easy access for leveling your cabinet
- Featuring EZ-Level™, our unique anti-tip design, which provides maximum stability and tipping resistance
- Highly visible safety and warning labels provide a permanent reminder and reference for following proper safety and usage practices
- Self-latching 3-point door locking system includes a heavy-duty enclosed staggering mechanism that ensures the doors close in proper order
- Fusible link assembly disconnects at 165° F to close doors automatically and keep cabinet contents protected
- Tilted spill-guide interior shelving directs spills to the back of the cabinet and into the retention sump area for easy cleaning
- Bright white shelves makes it easier to identify spills
- High-quality powder paint finish has 10x the corrosion resistance, 5x the abrasion resistance, and 2x the chip and scratch resistance of liquid paint



■ Use yellow Crescent JOBBOX® cabinets to store flammable liquids

Cat. No.	Capacity	Color	Length	Width	Height	Inside Length	Inside Width	Inside Height	Usable Cu. Ft.	App. Ship Wt.
1-754640	30 Gallons	Yellow	46.12 in	23.25 in	45.72 in	42.84 in	17.32 in	36.47 in	15.66 ft³	235 lb
1-757640	45 Gallons	Yellow	46.07 in	23.25 in	66.71 in	42.84 in	17.36 in	57.42 in	24.71 ft³	325 lb

■ Use red Crescent JOBBOX® cabinets to store paints, inks, and combustibles

Cat. No.	Capacity	Color	Length	Width	Height	Inside Length	Inside Width	Inside Height	Usable Cu. Ft.	App. Ship Wt.
1-754610	30 Gallons	Red	46.12 in	23.25 in	45.72 in	42.84 in	17.32 in	36.47 in	15.66 ft³	235 lb
1-757610	45 Gallons	Red	46.07 in	23.25 in	66.71 in	42.84 in	17.36 in	57.42 in	24.71 ft³	325 lb

■ Use green Crescent JOBBOX® cabinets to store pesticides and insecticides

Cat. No.	Capacity	Color	Length	Width	Height	Inside Length	Inside Width	Inside Height	Usable Cu. Ft.	App. Ship Wt.
1-754620	30 Gallons	Green	46.12 in	23.25 in	45.72 in	42.84 in	17.32 in	36.47 in	15.66 ft³	235 lb
1-757620	45 Gallons	Green	46.07 in	23.25 in	66.71 in	42.84 in	17.36 in	57.42 in	24.71 ft³	325 lb

Type I Canisters

- Rugged tubular steel handle
- Spring-loaded, gasketed lid seals automatically after handle is released
- High quality terne plate steel construction for superior corrosion resistance
- High visibility safety label
- Zinc plated flame arrestors
- Single opening recommended for storage, but can be used with a funnel for pouring
- Use yellow to store flammable liquids and red to store paints, inks, and combustibles



Cat. No.	Color	Capacity	Dia. (in) x Hose	Approvals / Listings	App. Ship Wt.
821990Y	Yellow	1 gal (US), 4 l	9 x 6	UL/ULC	7 lb
811990YF*	Yellow	1 gal (US), 4 l	9 x 6	UL/ULC	5 lb
812990Y	Yellow	2 gal (US), 7.5 l	9 x 6	UL/ULC	6 lb
812990YF*	Yellow	2 gal (US), 7.5 l	9 x 6	UL/ULC	6 lb
815990Y	Yellow	5 gal (US), 19 l	11.5 x 9	UL/ULC	9 lb
815990YF*	Yellow	5 gal (US), 19 l	11.5 x 9	UL/ULC	9 lb
812990	Red	2 gal (US), 7.5 l	9 x 6	UL/ULC	6 lb
812990F*	Red	2 gal (US), 7.5 l	9 x 6	UL/ULC	6 lb
815990	Red	5 gal (US), 19 l	11.5 x 9	UL/ULC	9 lb
815990F*	Red	5 gal (US), 19 l	11.5 x 9	UL/ULC	9 lb

* Funnel Included

Type II Canisters

- Rugged tubular steel handle
- Spring-loaded, gasketed lid seals automatically after handle is released
- High quality terne plate steel construction for superior corrosion resistance
- High visibility safety label
- Zinc plated flame arrestors
- Two openings, one for filling and one for pouring
- Spark-resistant brass tip on pouring hose
- Use yellow to store flammable liquids and red to store paints, inks, and combustibles



Cat. No.	Color	Capacity	Dia. (in) x Hose	Approvals / Listings	App. Ship Wt.
822990Y	Yellow	2 gal (US), 7.5 l	9 x 6	UL/ULC	8.5 lb
825990Y	Yellow	5 gal (US), 19 l	11.5 x 9	UL/ULC	12 lb
822990	Red	2 gal (US), 7.5 l	9 x 6	UL/ULC	8.5 lb
825990	Red	5 gal (US), 19 l	11.5 x 9	UL/ULC	12 lb

Safety Accessories

- Replacement nozzles and funnel for safety cans



Cat. No.	Description	Size	Product Weight
800990	Replacement Funnel	-	0.100 lb
830990	6" Replacement Nozzle	6 in	1.1 lb
835990	9" Replacement Nozzle	9 in	1.1 lb

26" Long Floor Model with Three Drawers

- Extruded heavy-duty drawer glides support up to 75 lbs per drawer
- Latches automatically lock the drawers when closed
- Pins prevent the drawers from rolling off the glides
- Moveable dividers to create different size bins
- Heavy-gauge aluminum is light enough for easy mobility and durable enough to stand up to heavy loads on top of and inside drawers



Cat. No.	Length	Width	Height	Drawer Compartments	Plastic Dividers	Usable Cu. Ft.	App. Ship Wt.
1405980	26 in	36 in	6 in	3	2	3.6 ft³	51.0 lb

26" Long Stacked Model with Six Drawers

- Extruded heavy-duty drawer glides support up to 75 lbs per drawer
- Latches automatically lock the drawers when closed
- Pins prevent the drawers from rolling off the glides
- Moveable dividers to create different size bins
- Heavy-gauge aluminum is light enough for easy mobility and durable enough to stand up to heavy loads on top of and inside drawers



Cat. No.	Length	Width	Height	Drawer Compartments	Plastic Dividers	Usable Cu. Ft.	App. Ship Wt.
1406980	26 in	36 in	12 in	6	2	7 ft³	81.0 lb

50" Long Floor Models

- Extruded heavy-duty drawer glides support up to 75 lbs per drawer
- Latches automatically lock the drawers when closed
- Pins prevent the drawers from rolling off the glides
- Moveable dividers to create different size bins
- Heavy-gauge aluminum is light enough for easy mobility and durable enough to stand up to heavy loads on top of and inside drawers



Cat. No.	Length	Width	Height	Drawer Compartments	Plastic Dividers	Usable Cu. Ft.	App. Ship Wt.
1401980	50 in	12 in	6 in	1	5	2.5 ft ³	31.0 lb
1402980	50 in	24 in	6 in	2	5	5.1 ft ³	61.0 lb
1403980	50 in	36 in	6 in	3	5	7.6 ft ³	89.0 lb
1404980	50 in	48 in	6 in	4	5	10.1 ft ³	119.0 lb

50" Long Stacked Models

- Extruded heavy-duty drawer glides support up to 75 lbs per drawer
- Latches automatically lock the drawers when closed
- Pins prevent the drawers from rolling off the glides
- Moveable dividers to create different size bins
- Heavy-gauge aluminum is light enough for easy mobility and durable enough to stand up to heavy loads on top of and inside drawers



Cat. No.	Length	Width	Height	Drawer Compartments	Plastic Dividers	Usable Cu. Ft.	App. Ship Wt.
1407980	50 in	12 in	12 in	2	5	5.1 ft ³	59.0 lb
1408980	50 in	12 in	18 in	3	5	7.6 ft ³	85.0 lb
1409980	50 in	12 in	24 in	4	5	10.1 ft ³	114.0 lb

Plastic Drawer Divider

- For use with Crescent JOBBOX aluminum drawer storage products
- Moveable divider to create different size bins
- Can be used with the following Crescent JOBBOX items: 1401980 through 1409980
- Customize storage with the addition of this divider
- Durable divider
- Sold as singles



Cat. No.	Length	Width	Height	Plastic Dividers	Used On	App. Ship Wt.
1410980	0.125 in	11.5 in	4.5 in	1	1401980 - 1409980	0.2 lb

9" Tall Drawer Units

- 14-gauge steel StorAll® drawer storage is designed to provide extreme durability and safety with unprecedented versatility
- Perfect for work trucks, trailers, and vans, StorAll® provides up to 50% more drawer weight capacity and up to 20% more storage capacity than competitors
- Drawers are customizable with adjustable front-to-rear dividers and bin dividers
- Grip-and-Release™ system allows safe opening and closing of heavy drawers on sloped surfaces
- Cabinet top and bottom reinforced with 12-gauge steel channels
- Built-in rain gutter channel, anti-skid strips, full bulb-shaped automotive weather stripping and 16-gauge galvanized movable bin dividers all benefit the user
- Steel plunger engages internal drawer stops, drawers have 650 lb. load rating and steel bearing tractors with 1,000 lb. rated bearings make for smooth drawer operation
- Recessed drawer fronts protect the handles from damage

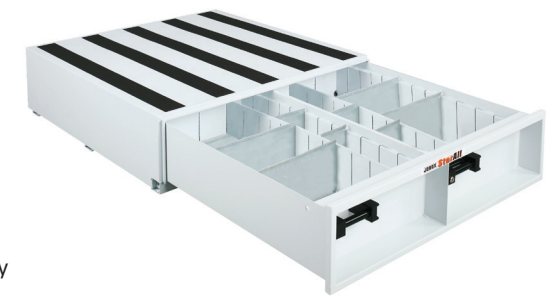

Cat. No.	Length	Width	Height	Drawer Compartments	Galvanized Dividers	Usable Cu. Ft.	App. Ship Wt.
661980	48 in	12 in	9 in	1	7	1 ft ³	115.0 lb
662980	48 in	24 in	9 in	2	13	2.3 ft ³	180.0 lb
663980	48 in	36 in	9 in	3	19	3.6 ft ³	222.0 lb
664980	48 in	48 in	9 in	4	24	5 ft ³	255.0 lb

13" Tall Drawer Units

- 14-gauge steel StorAll® drawer storage is designed to provide extreme durability and safety with unprecedented versatility
- Perfect for work trucks, trailers, and vans, StorAll® provides up to 50% more drawer weight capacity and up to 20% more storage capacity than competitors
- Drawers are customizable with adjustable front-to-rear dividers and bin dividers
- Grip-and-Release™ system allows safe opening and closing of heavy drawers on sloped surfaces
- Cabinet top and bottom reinforced with 12-gauge steel channels
- Built-in rain gutter channel, anti-skid strips, full bulb-shaped automotive weather stripping and 16-gauge galvanized movable bin dividers all benefit the user
- Steel plunger engages internal drawer stops, drawers have 650 lb. load rating and steel bearing tractors with 1,000 lb. rated bearings make for smooth drawer operation
- Recessed drawer fronts protect the handles from damage



Cat. No.	Length	Width	Height	Drawer Compartments	Galvanized Dividers	Usable Cu. Ft.	App. Ship Wt.
665980	48 in	12 in	13 in	1	7	1.8 ft ³	155.0 lb
666980	48 in	24 in	13 in	2	13	4.2 ft ³	245.0 lb
667980	48 in	36 in	13 in	3	19	6.6 ft ³	305.0 lb
668980	48 in	48 in	13 in	4	24	9 ft ³	380.0 lb

RSL™ Single Lid Paddle Handle Aluminum Crossovers

- Lid reinforced with RSL™ rigid structural lid bolster for superior strength
- Adjustable lid strikers keep the lid locked down tight for improved security
- High-strength body design resists cargo damage and protects the locking mechanism
- Leak proof stainless steel paddle handles prevent moisture from entering
- Self rising lids with dual gas spring lid lifts for easy access
- Small parts storage tray for organization
- Built in storage bins on both ends for convenient small item storage
- Lid locks from drivers side but can be opened from either side of vehicle

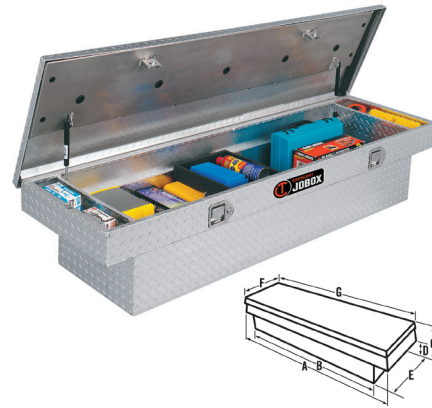

Bright Cat. No.	Black Cat. No.	Size	A	B	C	D	E	F	G	App. Ship Wt.
1-304000	1-304002	Mid-Size	62.75 in	50.5 in	14.25 in	9 in	17 in	20.25 in	63.5 in	36.0 lb
1-300000	1-300002	Fullsize	69.125 in	59.125 in	14.25 in	9 in	17 in	20.25 in	70 in	36.0 lb
1-301000	1-301002	Deep Fullsize	69.125 in	59.125 in	17.25 in	12 in	17 in	20.25 in	70 in	45.5 lb

Mid-Lid RSL™ Aluminum Crossovers

- Lid reinforced with RSL™ rigid structural lid bolster for superior strength
- Adjustable lid strikers keep the lid locked down tight for improved security
- High-strength body design resists cargo damage and protects the locking mechanism
- Leak proof stainless steel paddle handles prevent moisture from entering
- Self rising lids with dual gas spring lid lifts for easy access
- Small parts storage tray for organization
- Built in storage bins on both ends for convenient small item storage
- Lid locks from drivers side but can be opened from either side of vehicle



Bright Cat. No.	Black Cat. No.	Size	A	B	C	D	E	F	G	App. Ship Wt.
1-306000	1-306002	Fullsize	69.125 in	59.125 in	14.25 in	9 in	17 in	20.25 in	70 in	37.0 lb

Slimline Single Lid Aluminum Crossovers

- Lid reinforced with RSL™ rigid structural lid bolster for superior strength
- Adjustable lid strikers keep the lid locked down tight for improved security
- High-strength body design resists cargo damage and protects the locking mechanism
- Leak proof stainless steel paddle handles prevent moisture from entering
- Self rising lids with dual gas spring lid lifts for easy access
- Small parts storage tray for organization
- Built in storage bins on both ends for convenient small item storage
- Lid locks from drivers side but can be opened from either side of vehicle

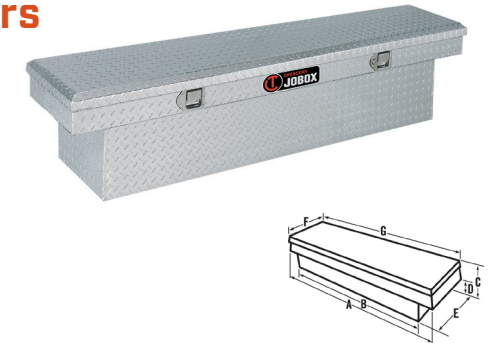

Bright Cat. No.	Black Cat. No.	Size	A	B	C	D	E	F	G	App. Ship Wt.
1-311000	1-311002	Fullsize	69.125 in	59-1/8 in	16 in	10.75 in	10.375 in	13.5 in	70 in	33.5 lb

Hybrid Single Lid Crossover

- Durable steel box construction with durable powdercoat finish and non-rusting aluminum treadplate lid
- High-strength body design resists cargo damage and protects the locking mechanism
- Adjustable lid strikers keep the lid locked down tight for improved security
- Heavy-duty gas springs for easy access
- Leak proof stainless steel paddle handles prevent moisture from entering
- Weathertight seal forms from compressed foam gasket



Cat. No.	Color	Size	A	B	C	D	E	F	G	App. Ship Wt.
DHC1450000	Black	Fullsize	70.1875 in	60 in	13.72 in	11.07 in	20.062 in	20.843 in	71.062 in	56 lb

Low-Profile, RSL™ Single Lid Paddle Handle Aluminum Crossovers

- Lid reinforced with RSL™ rigid structural lid bolster for superior strength
- Adjustable lid strikers keep the lid locked down tight for improved security
- High-strength body design resists cargo damage and protects the locking mechanism
- Leak proof stainless steel paddle handles prevent moisture from entering
- Self rising lids with dual gas spring lid lifts for easy access
- Small parts storage tray for organization
- Built in storage bins on both ends for convenient small item storage
- Lid locks from drivers side but can be opened from either side of vehicle

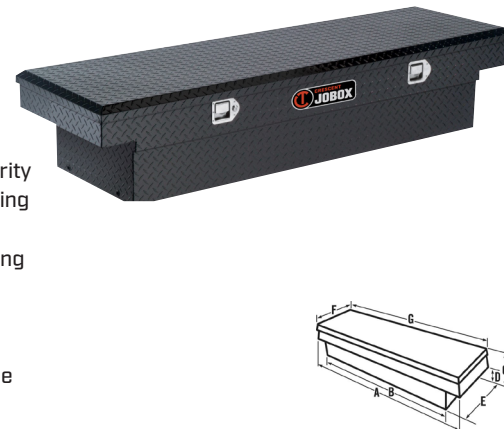

Bright Cat. No.	Black Cat. No.	Size	A	B	C	D	E	F	G	App. Ship Wt.
1-310000	1-310002	Mid-Size	62.75 in	50.5 in	14.25 in	11.812 in	17 in	20.25 in	63.5 in	36.0 lb
1-302000	1-302002	Fullsize	69.125 in	59.125 in	14.25 in	11.812 in	17 in	20.25 in	70 in	37.0 lb

TRUCK BOX
CROSSOVERS

TRUCK BOX
CROSSOVERS

Gear-Lock™ Paddle Handle Single Lid Crossovers

- RSL™ laminated rigid structural lid bolster for superior strength
- Self-aligning hoop lid strikers lock the lid down tight for improved security
- High-strength body design resists cargo damage and protects the locking mechanism
- Gear-Lock™ latches ratchet lid tightly closed for superior security
- Wide stainless steel paddle handles resist corrosion
- Self-rising lids with dual gas spring lid lifts for easy access
- Small parts storage tray for organization
- Built-in storage bins on both ends for convenient small item storage
- Wide top box flanges provide extra strength and durability
- Lid locks from drivers side but can be opened from either side of vehicle

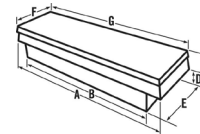

Bright Cat. No.	Black Cat. No.	Size	A	B	C	D	E	F	G	App. Ship Wt.
1-351000	1-351002	Full Size Low Profile	69 in	59 in	14.25 in	12.125 in	20.25 in	21 in	70 in	56.0 lb
1-232000	1-232002	Full Size	69 in	59 in	14.25 in	9 in	20.25 in	21 in	70 in	50.5 lb
1-238000	1-238002	Full Size Mid-Lid	69 in	59 in	14.25 in	9 in	20.25 in	21 in	70 in	52.5 lb

Push-Button Premium Gear-Lock™ Single Lid Aluminum Crossovers

- Gear-Lock™ self-adjusting dual rotary lock system always latches and closes for superior security
- Self-aligning latch pins pivot from side to side and lock the lid into Gear-Lock™ latch for premium security
- High-strength body and full-width lock console resist cargo damage and protect the locking mechanism
- RSL™ laminated rigid structural lid bolster for superior strength
- Tough Armor-Brite® powder paint finish has superior rust resistance
- Self-rising lids with dual gas spring lid lifts for easy access
- 4-compartment storage tray assists with organization
- Built-in storage bins on both ends for convenient small item storage
- Wide top box flanges provide extra strength and durability
- Lid locks from drivers side but can be opened from either side of vehicle

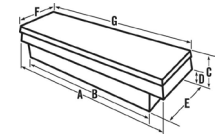

Bright Cat. No.	Black Cat. No.	Size	A	B	C	D	E	F	G	App. Ship Wt.
PAC1580000	PAC1580002	Fullsize	70.125 in	60.125 in	14.25 in	9 in	20.25 in	20.88 in	71 in	76.5 lb
PAC1582000	PAC1582002	Deep Fullsize	70.125 in	60.125 in	17.25 in	12 in	20.25 in	20.88 in	71 in	80.0 lb
PAC1585000	PAC1585002	Super Deep Fullsize	70.125 in	60.125 in	19.875 in	14.625 in	20.25 in	21 in	71 in	83.0 lb

Low-Profile Push Button Gear-Lock™ Single Lid Aluminum Crossovers

- Gear-Lock™ self-adjusting dual rotary lock system always latches and closes for superior security
- Self-aligning latch pins pivot from side to side and lock the lid into Gear-Lock™ latch for premium security
- High-strength body and full-width lock console resist cargo damage and protect the locking mechanism
- RSL™ laminated rigid structural lid bolster for superior strength
- Tough Armor-Brite® powder paint finish has superior rust resistance
- Self-rising lids with dual gas spring lid lifts for easy access
- 4-compartment storage tray assists with organization
- Built-in storage bins on both ends for convenient small item storage
- Wide top box flanges provide extra strength and durability
- Lid locks from drivers side but can be opened from either side of vehicle

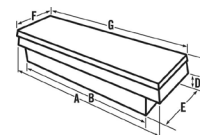

Bright Cat. No.	Black Cat. No.	Size	A	B	C	D	E	F	G	App. Ship Wt.
PAC1357000	PAC1357002	Fullsize	70 in	60.25 in	15.125 in	12.125 in	17.875 in	21 in	71.125 in	76.5 lb

Mid-Lid Gear-Lock™ Push Button Aluminum Crossovers

- Gear-Lock™ self-adjusting dual rotary lock system always latches and closes for superior security
- Self-aligning latch pins pivot from side to side and lock the lid into Gear-Lock™ latch for premium security
- High-strength body and full-width lock console resist cargo damage and protect the locking mechanism
- RSL™ laminated rigid structural lid bolster for superior strength
- Tough Armor-Brite® powder paint finish has superior rust resistance
- Self-rising lids with dual gas spring lid lifts for easy access
- 4-compartment storage tray assists with organization
- Built-in storage bins on both ends for convenient small item storage
- Wide top box flanges provide extra strength and durability
- Lid locks from drivers side but can be opened from either side of vehicle

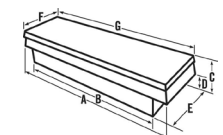

Bright Cat. No.	Black Cat. No.	Size	A	B	C	D	E	F	G	App. Ship Wt.
PAC1596000	PAC1596002	Fullsize	70.125 in	60.125 in	14.25 in	9 in	20.25 in	20.875 in	71 in	62.5 lb

Limited Edition Premium Push Button Gear-Lock™ Truck Boxes

- Gear-Lock™ end-mounted push button locks ratchet lid tightly closed for superior security
- Self-aligning latch pins pivot from side to side and lock the lid into Gear-Lock™ latch for premium security
- High-strength body and full-width lock console resist cargo damage and protect the locking mechanism
- RSL™ laminated rigid structural lid bolster for superior strength
- Tough Armor-Brite® powder paint finish has superior rust resistance
- Self rising lids with dual gas spring lid lifts for easy access
- 4-compartment storage tray assists with organization
- Built in storage bins on both ends for convenient small item storage
- Wide top box flanges provide extra strength and durability

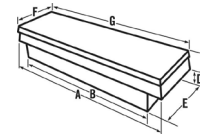

Cat. No.	Color	Size	A	B	C	D	E	F	G	App. Ship Wt.
1701000	Bright	Deep Super Duty & Fullsize Deep	71.125 in	58.75 in	18 in	12 in	20.25 in	21 in	72.125 in	77.0 lb

Gull Wing Gear-Lock™ Push Button Steel Crossovers

- Gear-Lock™ self adjusting dual rotary lock system always latches and closes for superior security
- Self-aligning latch pins pivot from side to side and lock the lid into Gear-Lock™ latch for premium security
- High-strength, self-rising lids will resist attempted break-ins better than other steel lids
- High-strength body design resists cargo damage and protects the locking mechanism
- End-mounted push buttons provide easy access
- Heavy-duty guards on single lid models protect the gas springs and extend long term durability
- Built-in storage bins on both ends and 4-compartment sliding tray for convenient small item storage

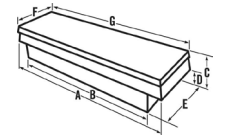

White Cat. No.	Black Cat. No.	Size	A	B	C	D	E	F	G	App. Ship Wt.
PSC1460000	PSC1460002	Fullsize	70.125 in	60.125 in	14.25 in	9 in	20.25 in	20.875 in	71 in	85.0 lb

TRUCK BOX
CROSSOVERS

Gear-Lock™ Push Button Single Lid Steel Crossovers

- Gear-Lock™ self adjusting dual rotary lock system always latches and closes for superior security
- Self-aligning latch pins pivot from side to side and lock the lid into Gear-Lock™ latch for premium security
- High-strength, self-rising lids will resist attempted break-ins better than other steel lids
- High-strength body design resists cargo damage and protects the locking mechanism
- End-mounted push buttons provide easy access
- Heavy-duty guards on single lid models protect the gas springs and extend long term durability
- Built-in storage bins on both ends and 4-compartment sliding tray for convenient small item storage
- Tough Armor-Brite® powder paint finish has superior rust resistance

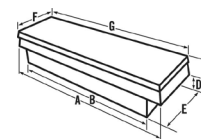

White Cat. No.	Black Cat. No.	Size	A	B	C	D	E	F	G	App. Ship Wt.
PSC1458000	PSC1458002	Compact	60.125 in	50.125 in	11.25 in	6 in	20.25 in	20.875 in	61 in	77.0 lb
PSC1455000	PSC1455002	Fullsize	70.125 in	60.125 in	14.25 in	9 in	20.25 in	20.875 in	71 in	94.0 lb
PSC1456000	PSC1456002	Deep Fullsize	70.125 in	60.125 in	17.25 in	12 in	20.25 in	20.875 in	71 in	101.0 lb
PSC1457000	PSC1457002	Deep & Extra-Wide Fullsize	70.125 in	60.125 in	17.25 in	12 in	29.25 in	30 in	71 in	175.5 lb

Aluminum Innersides

- Lid reinforced with bolster for superior strength
- Adjustable lid strikers keep the lid locked down tight for improved security
- High-strength body design resists cargo damage and protects the locking mechanism
- Leak proof stainless steel paddle handles prevent moisture from entering
- Self rising lids with gas spring lid lifts for easy access
- Includes mounting kit and supporting legs with hardware

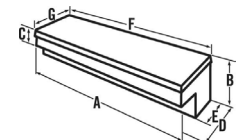
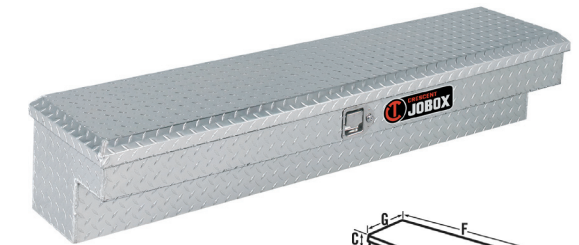

Bright Cat. No.	Black Cat. No.	Size	A	B	C	D	E	F	G	Usable Cu. Ft.	App. Ship Wt.
1-312000	1-312002	49" Long Lid	47.75 in	11 in	5.375 in	12.25 in	8 in	48.625 in	13 in	2.7 ft³	24.5 lb
1-313000	1-313002	59" Long Lid	57.75 in	11 in	5.375 in	12.25 in	8 in	58.625 in	13 in	3.2 ft³	30.0 lb

TRUCK BOX
INNERSIDES

Gear-Lock™ Aluminum Innersides

- Gear-Lock™ self adjusting dual rotary lock system always latches and closes for superior security
- Self-aligning latch pins pivot from side to side and lock the lid into Gear-Lock™ latch for premium security
- High-strength RSL™ laminated 3-layer rigid structural lid is the strongest, most rigid aluminum lid we've tested
- Reinforced high-strength body and full-width lock console resists cargo damage and protects the lock system
- Heavy-duty guards protect the vertical-action gas spring lid lifts and help ensure long-term durability
- Built-in full-length storage compartment for small tools and parts
- Includes mounting kit and supporting legs with hardware

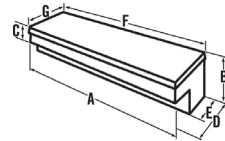

Bright	Black		A	B	C	D	E	F	G	Usable Cu. Ft.	App. Ship Wt.
Cat. No.	Cat. No.	Size									
PAN1441000	PAN1441002	48 1/2" Long Lid	47.75 in	11 in	5.375 in	12.125 in	7.875 in	48.5 in	13 in	2.7 ft³	28.5 lb
PAN1442000	PAN1442002	58 1/2" Long Lid	57.75 in	11 in	5.375 in	12.125 in	7.875 in	58.5 in	13 in	3.2 ft³	32 lb

Aluminum Topsides

- Reinforced rain gutter doors seal around topside opening to prevent leakage or moisture
- Heavy-duty hinges provide high strength security and longevity
- Stainless steel rotating t-handle pulls the door tight against the seal
- Quick release coated aircraft cables allow door to drop down 180 degrees for full accessibility
- Automotive bulb weather stripping seals door 360°
- Includes mounting kit and supporting legs with hardware

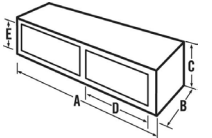

Bright	Black		A	B	C	D	E	Usable Cu. Ft.	App. Ship Wt.
Cat. No.	Cat. No.	Size							
572000	572002D	72" Long	72 in	15 in	17 in	40 in	12.75 in	9.4 ft³	55.0 lb
573000	573002	88" Long	88 in	15 in	17 in	40 in	12.75 in	11.5 ft³	58.0 lb
574000D	574002D	96" Long	96 in	15 in	17 in	40 in	12.75 in	12.5 ft³	63.0 lb

Gear-Lock™ Steel Innersides

- Gear-Lock™ push button lock ratchets lid to box for superior security
- Self-aligning latch pins pivot from side to side and lock the lid into Gear-Lock™ latch for premium security
- High-strength body design resists cargo damage and protects the locking mechanism
- Self rising lids with gas spring lid lifts for easy access
- Tough Armor-Brite® powder paint finish has superior rust resistance
- RSL™ laminated rigid structural lid bolster for superior strength
- Built-in front storage for convenient small item storage
- Includes mounting kit and supporting legs with hardware

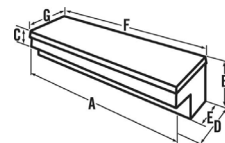

White	Black		A	B	C	D	E	F	G	Usable Cu. Ft.	App. Ship Wt.
Cat. No.	Cat. No.	Size									
PSN1451000	PSN1451002	47 1/2" Long Lid	47.75 in	11.125 in	5.375 in	12.25 in	8.25 in	47.5 in	12 in	2.6 ft³	48.5 lb
PSN1452000	PSN1452002	58 1/2" Long Lid	57.75 in	11.125 in	5.375 in	12.25 in	8.25 in	58.5 in	12 in	3.2 ft³	60.0 lb

Steel Topsides

- Reinforced rain gutter doors seal around topside opening to prevent leakage or moisture
- Heavy-duty hinges provide high strength security and longevity
- Stainless steel rotating t-handle pulls the door tight against the seal
- Quick release coated aircraft cables allow door to drop down 180 degrees for full accessibility
- Automotive bulb weather stripping seals door 360°
- Includes mounting kit and supporting legs with hardware
- Tough Armor-Brite® powder paint finish has superior rust resistance

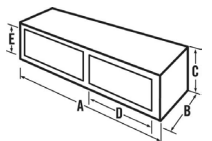

Cat. No.	Color	Size	A	B	C	D	E	Usable Cu. Ft.	App. Ship Wt.
577000	White	72" Long	72 in	15 in	17 in	40 in	12.75 in	9.4 ft³	118.0 lb
578000	White	88" Long	88 in	15 in	17 in	40 in	12.75 in	11.5 ft³	140.0 lb
579000	White	96" Long	96 in	15 in	17 in	40 in	12.75 in	12.5 ft³	146.0 lb

TRUCK BOX
INNERSIDES

TRUCK BOX
TOPSIDES

Steel Underbed Boxes

- Industrial grade steel hinges and drop down door for easy loading and unloading and the high strength door cables create versatility and strength
- Bulb-shaped automotive weather stripping and extended rain gutter help keep out the weather
- Quick release keyway connectors allow the door to drop down when cables are detached
- Rugged, one-piece lock housing helps protect the lock components and provides extra strength to the door
- Rotating t-handle with a reinforced cam lock, three-point locking system and one-piece lock housing provide greater security

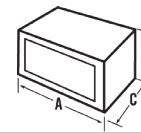

White Cat. No.	Black Cat. No.	Length	Width	Height	Usable Cu. Ft.	App. Ship Wt.
7924160	7924162	24 in	16 in	14 in	3.06 ft ³	55 lb
790980	790982	24 in	18 in	18 in	4.16 ft ³	68 lb
7924240	7924242	24 in	24 in	24 in	7.96 ft ³	94 lb
791980	791982	30 in	18 in	18 in	5.20 ft ³	80 lb
7930240	7930242	30 in	24 in	24 in	9.95 ft ³	110 lb
7936140	7936142	36 in	12 in	14 in	3.43 ft ³	68 lb
7936160	7936162	36 in	16 in	14 in	4.0 ft ³	76 lb
792980	792982	36 in	18 in	18 in	6.24 ft ³	92 lb
7936240	7936242	36 in	24 in	24 in	11.94 ft ³	126 lb
793980	793982	48 in	18 in	18 in	8.32 ft ³	117 lb
7948240	7948242	48 in	24 in	24 in	15.92 ft ³	158 lb
794980	794982	60 in	18 in	18 in	10.40 ft ³	142 lb
7960240	7960242	60 in	24 in	24 in	18.90 ft ³	190 lb
7972180	7972182	72 in	18 in	18 in	12.51 ft ³	168 lb

Mounting Brackets

- Heavy-duty 2" C-channel brackets for mounting underbed boxes
- Brackets have multiple mounting holes for easy installation
- Sold in pairs



Cat. No.	Length	Width	Height	App. Ship Wt.
228000	18 in	2 in	18 in	15.0 lb
229000	24 in	2 in	24 in	33.5 lb

Aluminum Portable Chests

- Removable and portable aluminum chests offer versatility wherever secure storage is needed
- Wide lifting handles are easy to grip and will support heavy loads
- Rugged aluminum strikers will adjust vertically and horizontally to keep the lid locked down tight
- Leak proof stainless steel paddle handles prevent moisture from entering
- Full weatherstripping helps seal out moisture and dust
- Gas spring lid lifts automatically raise lid and allows for easier access

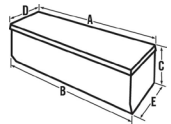

Cat. No.	Color	Size	A	B	C	D	E	App. Ship Wt.
220000D	Bright	37" Long	37 in	36 in	14.5 in	18 in	20 in	33.0 lb
221000D	Bright	49" Long	49 in	48 in	18 in	18 in	20 in	43.0 lb
222000D	Bright	57" Long	57 in	56 in	18 in	18 in	20 in	50.0 lb

Aluminum Chests for Trucks

- Recessed hinge allows the lid to fully open when the back of the chest is placed against another object
- Rugged aluminum construction with reinforced lid for maximum strength and security
- Gas spring lid lifts allow easier access
- Leak proof stainless steel paddle handles prevent moisture from entering
- Full weatherstripping helps seal out moisture and dust
- Tapered lower front wall will fit better in trucks with all types of bed liners

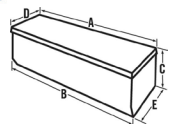

Cat. No.	Color	Size	A	B	C	D	E	App. Ship Wt.
808000	Bright	36 in	36.75 in	36 in	15.5 in	17.25 in	17 in	25.5 lb
896260	Bright	58 in	59.5 in	58.5 in	17.875 in	18.75 in	17.75 in	47.5 lb
896262	Black	58 in	59.5 in	58.5 in	17.875 in	18.75 in	17.75 in	47.5 lb

Hybrid Fullsize Portable Chest

- Stylish tread plate aluminum lid with rigid steel base for support
- Removable and portable chest offers versatility where secure storage is needed
- Leak proof stainless steel paddle handles prevent moisture from entering
- Gas spring lid lifts automatically raise lid and allow for easier access
- Wide lifting handles are easy to grip and will support heavy loads
- Full weatherstripping helps seal out moisture and dust
- Rugged aluminum strikers will adjust horizontally to keep the lid locked down tight

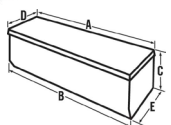

Cat. No.	Color	Size	A	B	C	D	E	App. Ship Wt.
DYH1453002	Black	Fullsize	49 in	48 in	18 in	21 in	20 in	50 lb

UNDERBED
BOXES

TRUCK
CHESTS

Gear-Lock™ Paddle Handle Aluminum Chests

- Gear-Lock™ paddle handle lock ratchets lid to box for superior security
- Self-aligning hoop strikers pivot from side-to-side and lock the lid for premium security
- RSL™ laminated rigid structural lid bolster for superior strength
- Self-rising lids with dual gas spring lid lifts for easy access
- Full weatherstripping helps seal out moisture and dust
- Wide top box flanges provide extra strength and durability
- Angled edges on front and side walls provide best fit, even when installed with a bed liner



Bright Cat. No.	Black Cat. No.	Size	A	B	C	D	E	App. Ship Wt.
1-350000	1-350002	Full Size Long	61 in	61.25 in	19.25 in	20.5 in	20 in	53.0 lb

Gear-Lock™ Aluminum Chests

- Gear-Lock™ self-adjusting dual rotary lock system always latches and closes for superior security
- Self-aligning latch pins pivot from side to side and lock the lid into Gear-Lock™ latch for premium security
- RSL™ laminated rigid structural lid bolster for superior strength
- High-strength body and full-width lock console resist cargo damage and protect the locking mechanism
- Self-rising lids with dual gas spring lid lifts for easy access
- Leak proof stainless steel paddle handles prevent moisture from entering
- Universal fit design features a tapered bottom section on the ends and front wall



Bright Cat. No.	Black Cat. No.	Size	A	B	C	D	E	App. Ship Wt.
PAH1420000	PAH1420002	SWB Fullsize	61 in	60.125 in	19.375 in	20.625 in	18.75 in	53.0 lb
PAH1424000	PAH1424002	Extra-Wide Fullsize	61 in	60.125 in	19.375 in	27.625 in	24.875 in	68.0 lb

Steel Portable Utility Chests

- 18-gauge steel construction with fully welded seams and formed edges
- Lock down chest and remove easily with quick connect brackets
- Sliding tray provides convenient storage for hand tools and small parts
- Full weatherstripping helps seal out moisture and dust
- Tough Armor-Brite® powder paint finish has superior rust resistance



Cat. No.	Color	Size	A	B	C	D	E	App. Ship Wt.
810000	White	32 in	32.625 in	32 in	12.75 in	11.25 in	10.75 in	31.5 lb

Aluminum Trailer Tongue Boxes

- Trailer tongue box mounts easily against rail or trailer wall
- Rugged aluminum construction with reinforced lid for maximum strength and security
- Offset gas spring lid lift allows easier access from drivers side
- Leak proof stainless steel paddle handles prevent moisture from entering
- Full weatherstripping helps seal out moisture and dust
- Tough Armor-Brite® powder paint finish has superior rust resistance

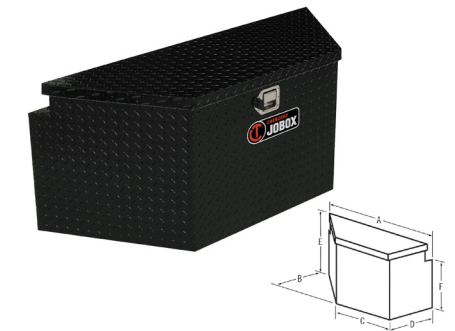

Cat. No.	Color	A	B	C	D	E
405000D	Bright	33 in	16 in	20 in	17.5 in	20.5 in
410000D	Bright	48 in	18 in	25 in	21.5 in	20.5 in

Steel Heavy-Duty Chest

- High strength beveled edge lid
- Sliding tray for small parts and tools
- Leak-proof stainless steel paddle handles
- Dual gas spring lid lifts for easy opening lid
- Bulb-shaped automotive weather stripping
- Channel reinforced front panel
- One-piece box body construction
- Recessed hinge



Cat. No.	Color	Size	A	B	C	D	E	App. Ship Wt.
817980	White	Fullsize Steel	59.125 in	58.5 in	19 in	20.5 in	20.25 in	129.0 lb

Aluminum Liquid Transfer Tanks

- Two full center baffles add extra strength and control the flow of the contents when moving
- 2" NPT reinforced bungs allow mounting a pump on either side of tank
- Four high strength brackets for securing the tank to the bed
- Lockable filler cap and coupler
- Heavy-duty 0.125" tread plate aluminum

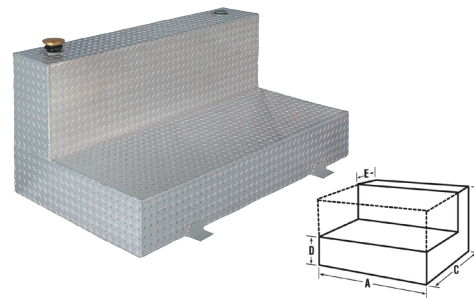

Cat. No.	Color	Shape	Safe Fill (US)	Max Fill (US)	A	Capacity (US)	B	C	D	E	App. Ship Wt.
439000	Bright	Square	47 gal	52 gal	23.25 in	50 gal	23.25 in	23.25 in	-	-	64.0 lb
438000	Bright	Rectangular	91 gal	102 gal	45.25 in	100 gal	23.25 in	23.25 in	-	-	94.0 lb
437000	Bright	L-Shaped	99 gal	104 gal	57.5 in	100 gal	25 in	31 in	9 in	10 in	112.0 lb

Fuel-N-Tool Combo Aluminum Transfer Tank

- Offers the convenience of a L-shaped transfer tank and a removable chest
- Two full center baffles add extra strength and control the flow of the contents when moving
- 2" NPT reinforced bungs allow mounting a pump on either side of the tank
- Four high strength brackets for securing the tank to the bed
- Leak proof stainless steel paddle handles prevent moisture and dirt from entering
- Chest provides 4.5 cubic feet of high-strength storage for tools and accessories
- RSL™ rigid structural lid, heavy-duty adjustable lid strikers, and high-strength body resist break-ins
- Self-rising lid has two heavy-duty gas spring lid lifts



Cat. No.	Color	Shape	Safe Fill (US)	Max Fill (US)	A	B	C	D	E	App. Ship Wt.
433000	Bright	L-Shaped	72 gal	77 gal	48.25 in	19 in	31 in	9 in	10.75 in	129.0 lb

Steel Transfer Tanks

- Tanks have internal baffles for extra strength and to control the flow of contents when moving
- 2" NPT reinforced bungs allow mounting a pump on either side of the tank
- Built-in lifting rings to assist with lifting and moving an empty tank
- Lockable filler cap and coupler prevent excessive pressure build up
- Heavy-duty brackets to secure the tank to the truck bed
- Safety fill capacity allows space for the contents to expand in warm weather
- Drain plug allows for safe drainage of combustible liquids

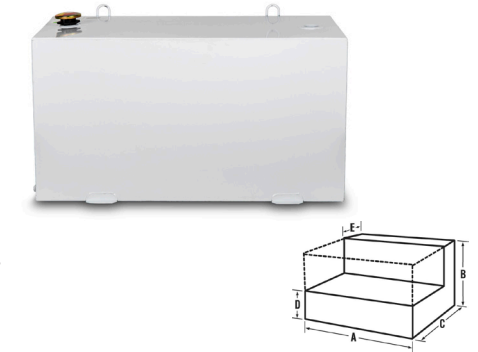

White Cat. No.	Black Cat. No.	Shape	Safe Fill (US)	Max Fill (US)	A	Capacity (US)	B	C	D	E	App. Ship Wt.
486000	—	Vertical	36 gal	42 gal	54 in	36 gal	19 in	9 in	-	-	97.0 lb
485000	—	Square	50 gal	55 gal	23.25 in	50 gal	24 in	23.25 in	-	-	85.5 lb
484000	484002	Rectangle	96 gal	107 gal	45.63 in	100 gal	24 in	23.25 in	-	-	145.0 lb
488000	488002	Low Profile L-Shape	76 gal	82 gal	46 in	85 gal	26 in	31 in	6.5 in	11 in	155.0 lb
482000	—	L-Shape	51 gal	54 gal	27 in	48 gal	26 in	31 in	9 in	11 in	106.0 lb
487000	—	L-Shape	88 gal	92 gal	54 in	88 gal	25 in	31 in	6.5 in	11 in	186.0 lb
480000	480002	L-Shape	103 gal	109 gal	54 in	100 gal	26 in	31 in	9 in	11 in	200.0 lb

Steel Transfer Tanks For 4-Door Trucks

- Built-in lifting rings to assist with lifting and moving an empty tank
- Lockable filler cap and coupler prevent excessive pressure build up
- Heavy-duty brackets to secure the tank to the truck bed
- Safety fill capacity allows space for the contents to expand in warm weather
- 2" NPT reinforced bungs allow mounting a pump on either side of the tank
- Drain plug allows for safe drainage of combustible liquids

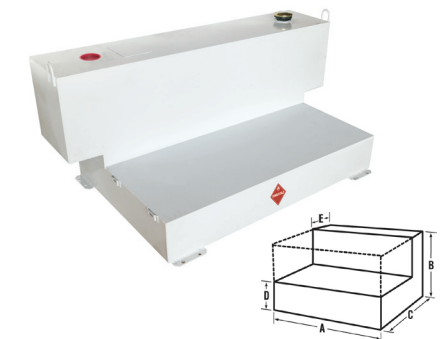

White Cat. No.	Black Cat. No.	Shape	Safe Fill (US)	Max Fill (US)	A	Capacity (US)	B	C	D	E	F	App. Ship Wt.
498000	498002	L-Shaped	98 gal	106 gal	60.25 in	100 gal	25 in	33 in	7.5 in	48.25 in	10.125 in	175.0 lb

Optional Casters

- Available in heavy-duty
- Set of 4 casters comes with two fixed and two swivel casters
- Size: 6 in; load rating: 3600 lb
- All purpose rubber tread for grip on many surfaces
- Wheels never puncture or go flat
- 3" x 3" hole patterns



Cat. No.	Width	Height	Load Rating	Size	Style	Used On
1-320990	-	-	2800 lb	4"	HD	-
1-321990	3.5 in	7.75 in	3600 lb	6 in	HD	All Crescent JOBBOX
1-320993	3.5 in	6 in	3600 lb	6 in	HD	All Crescent JOBBOX

Touch Up Paint

- Crescent JOBBOX on site storage touch up paint
- Available in 12 oz cans
- Color is Crescent JOBBOX red/rust



Cat. No.	Color	Used On	Product Weight
82936	Rust	All JOBBOX Models	1.100 lb

Removable Trays

- Built-in handles
- Convenient for hand tools and small parts
- Hemmed edges add strength and eliminate sharp edges
- Powder paint

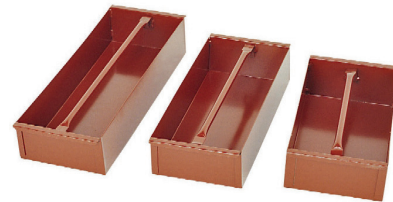

Cat. No.	Length	Width	Height	Used On
626990	22.187 in	8 in	4 in	1-654990, 1-655990, 1-658990
627990	28.187 in	8 in	4 in	1-656990
628990	18.187 in	8 in	4 in	1-652990, 1-653990
620990	21.875 in	8 in	4 in	635990

Replacement Parts for Models 675, 676, 677 & 678



Cat. No.	Description	Length	Width	Height	Used On	Product Weight
608990	Shelf	21.875 in	16.875 in	-	Models 677 & 678	8.000 lb
605990	2-1/2" Deep Drawer	21.875 in	16.875 in	2.5 in	Models 675 & 676	16.000 lb
609990	2-1/2" Deep Drawer	21.875 in	16.875 in	2.5 in	Models 677 & 678	17.000 lb
606990	4-1/2" Deep Drawer	21.875 in	16.875 in	4.5 in	Models 675 & 676	19.000 lb
610990	4-1/2" Deep Drawer	21.875 in	16.875 in	4.5 in	Models 677 & 678	18.100 lb
607990	5-1/2" Deep Drawer	21.875 in	16.875 in	5.5 in	Models 675 & 676	19.000 lb
611990	5-1/2" Deep Drawer	21.875 in	16.875 in	5.5 in	Models 677 & 678	21.000 lb
616990	10" Deep Drawer	21.875 in	16.875 in	10 in	Models 675 & 676	17.800 lb
617990	10" Deep Drawer	21.875 in	16.875 in	10 in	Models 677 & 678	19.300 lb
612990	Optional 2nd Push Handle	21.875 in	16.875 in	2.0 in	Models 675 & 676	2.000 lb

PRODUCT	PAGE	PRODUCT	PAGE	PRODUCT	PAGE	PRODUCT	PAGE	PRODUCT	PAGE	PRODUCT	PAGE	PRODUCT	PAGE	PRODUCT	PAGE
Q															
00024NN	250	03863NN	249	06601NN	251	0890SMC	181	13930NN	257	17615N	260	1-400990	301	21503N	274
00047NN	250	0390CSP	182	06602NN	251	09179N	254	1401980	308	17683N	260	1-401990	301	21511N	274
00070NN	250	0390FC	178	06686NN	251	0990T	184	1402980	308	17751N	260	1-402990	301	21512	273
0090FC	178	0390FCS	182	066FN	228	1		1403980	308	17873N	262	1-403990	301	21513	273
0090MC	177	0390MC	177	06704NN	254	10SN	167	1404980	308	17903N	262	1-510990	300	21514	273
0090MCP	177	0390MCP	177	06706NN	254	11904	255	1405980	307	17910N	262	1-657990	296	21515	273
0090MNE	178	0390MCX	179	06711N	252	11936	256	1406980	307	18057N	262	1-669990	300	21516	273
0190FC	178	0390MHX	180	06773N	252	11969	256	1407980	308	18130N	261	1-674990	299	21520N	274
0190FCX	179	0390MLN	187	06804N	252	12019	255	1408980	308	18155N	261	1-679990	303	21522N	274
0190MC	177	0390MTN	182	06836N	252	12051	256	1409980	308	18846N	260	1-680990	296	21524N	274
0190MCP	177	03929NN	249	06867N	252	12084	256	14106MN	257	18861N	260	1-693990	302	21526N	274
0190MCS	180	03980NN	249	06898N	252	12131	255	1410980	308	18924NNN	260	1-694990	301	21528N	274
0190MCX	179	04695N	250	0690TN	183	12134	255	14162MN	257	19136N	261	1-695990	301	21687HNN	245;253
0190MHC	180	04729N	250	06930N	252	12166	256	14224MN	257	193610CVSMNN	136	1-697990	301	21687NN	253
0190MNE	178	04762N	250	06961N	252	12199	256	14255MN	247;257	193610VNN	136	1-698990	301	21690NN	248
0190MTN	182	04795N	250	06992N	252	12248	255	14290MN	257	19394N	261	1-750610	304	21694HNN	246;253
02144N	256	04828N	250	07054N	252	12790	255	14341NNN	257	19427N	261	1-750620	304	21694NN	253
02147N	256	04861N	250	07085N	252	12857	255	14547MN	257	19460N	261	1-750640	304	21701HNN	245;253
02230B	256	04896N	250	07657NN	252	12967	255	14599MN	257	19493N	261	1-753610	304	21701NN	253
02244NN	257	04927N	250	07688NN	252	13033	255	14665MN	257	1-232000	312	1-753620	304	21708NN	255
02373NN	258	04960N	250	07719NN	252	13081	255	14729NN	257	1-232002	312	1-753640	304	21715	255
02375NN	258	04995N	250	07835N	252	13147	255	1490MC	177	1-238000	312	1-754620	305	21729HNN	245;246;257
0290FC	178	05026N	250	07842N	252	13262	255	1490MCP	177	1-238002	312	1-756610	304	21729NN	257
0290FCS	182	05059N	251	07851N	252	13310	255	1490MTN	182	1-300000	310	1-756620	304	21736NN	257
0290FHJN	183	05090N	250	07863N	252	13343	255	14942MN	257	1-300002	310	1-756640	304	21743NN	257
0290MC	177	05094N	250	07894NN	253	13376	255	14992MN	257	1-301000	310	1-757620	305	21745N	250
0290MCP	177	05125N	250	07917NN	253	19875	261	15024NN	257	1-301002	310	1-758610	304	21746HN	250
0290MCX	179	05158N	251	07941NN	253	100010VNN	134	15056NN	257	1-302000	310	1-758620	304	21748HNN	245;249
0290MLC	188	05190N	250	08243NN	253	10008VNN	134	15708N	167	1-302002	310	1-758640	304	21825NN	248;253
03367NN	249	05194N	250	08306NN	254	10336CVNN	135	15718N	167	1-304000	310	1-759610	304	21832NN	247;253
03434NN	249	05258N	251	08354NN	253	10337CVNN	135	15925NNN	259	1-304002	310	1-759620	304	21839NN	247;253
03467NN	249	05307N	250	08385NN	253	10660MN	227	15991NNN	259	1-306000	311	1-759640	304	21842HNN	245;253
03500NN	249	05738N	251	08416NN	254	10660N	227	16036NNN	259	1-310000	310	2		21842NN	246;253
03533NN	249	05771N	251	08497NN	253	11418C	276	16102NNN	259	1-310002	310	2DAN	168	21846NN	248;255
03534NN	249	05804N	251	08529NN	254	11419C	276	16147NNN	259	1-311000	311	20189NN	272	21853	255
03566NN	249	05853N	251	08560NN	254	11526NN	255	16507NN	258	1-311002	311	20509CVSMLNN	134	21854	246;247;255
03599NN	249	0590MC	177	08642NN	253	11592NNN	256	16540N	258	1-312000	315	20509NN	134	21857LN	246;250
03632NN	249	0590MHX	180	08673NN	254	11748NN	255	16573NN	258	1-312002	315	21458	272	21858N	246;247;250
03633NN	246;249	0590RBJN	189	08704NN	254	120PN	219	166	166	1-313000	315	21467	272	21860NNN	246;260
03665NN	249	05919N	251	08737NN	253	120TPN	219	16663NN	258	1-313002	315	21470N	274	21862NN	249
03698NN	249	05968N	251	08768NN	254	1261MEN	224	16729NN	258	1-320990	324	21471N	274	21866NN	246;247;248;257
03731NN	249	06001NN	251	08799NN	254	1290G	185	16761NN	258	1-320993	324	21474H	273	21867NN	249
03732NN	246;247;249	06034N	251	08832NN	253	1290SF590N	234	16827NN	258	1-321990	324	21474U	272	21868HNN	245;246;249
03762NN	249	06084N	251	08894NN	254	1293SF590N	234	1701000	314	1-350000	320	21476N	274	21868NN	246;247;249
03764NN	249	06117N	251	0890CSFW	184	1293SM590N	234	175E	161	1-350002	320	21485N	274	21870NNN	260
03797NN	249	06150N	251	0890CSJ	183	13807MN	257	175E5	161	1-351000	312	21493	273	21873NN	257
03830NN	249	062CMEN	228	0890MC	181	13875MN	257	17505N	258	1-351002	312	21494N	274	21874NN	257

Continued on next page

PRODUCT	PAGE	PRODUCT	PAGE	PRODUCT	PAGE	PRODUCT	PAGE	PRODUCT	PAGE	PRODUCT	PAGE	PRODUCT	PAGE	PRODUCT	PAGE
21878N	261	35031N	269	37947	266	428N	163	606990	325	664980	309	7960240	318	8886CVNN	133
21881N	250	35061N	269	38059	266	438N	165	607990	325	665980	309	7960242	318		
21908N	244	35073N	269	39855N	267	433000	322	608990	325	666980	309	7972180	318	9	
21910N	244	35108N	269	39861N	267	437000	322	609990	325	667980	309	7972182	318	99150LN	239
21981N	244	35114N	269	39873N	267	438000	322	610990	325	668980	309			9175N	239
2200000	319	36018N	267	39881N	267	439000	322	611990	325	675990	302	8		9190C	188
22015HNNN	245	36219N	268	39893N	267	480000	323	612990	325	675996	302	80170	190	9190NE	188
22015NNN	248	36227N	268	39899N	267	480002	323	616990	325	676990	302	80176	190	9290C	188
22025NNN	247	36253N	268	39905N	267	482000	323	617990	325	676996	302	80263	190	9336CVNN	133
22030HNNN	245	36281N	268	39911N	267	484000	323	620990	324	677990	302	80269	190	9336NN	133
22030NNN	246	36521N	270	39923N	267	484002	323	621FTN	225	678990	302	80299	191	9337CVNN	133
22040NNN	247	36527N	270	39929N	267	485000	323	622FTN	225	682990	303	80814	195	953FTN	225
22062NNN	248	36533N	270	39935N	267	486000	323	623FTN	225	6990FS	185	80951	192	954FTN	225
2210000	319	36539N	270	39947N	267	487000	323	624FTN	225			80952	193	966N	228
22150HIN	246	36545N	270	39965N	267	488000	323	62635N-02	196	7		80956	192		
2220000	319	36557N	270	39971N	267	488002	323	626FTN	225	7030	217	80965	193	A	
228000	318	36563N	270	39971N	267	488002	323	626990	324	7060	217	80968	194	AC210BK	7
229000	318	36569N	270	39992N	267	498000	323	62706N-02	196	706L	217	80969	194	AC210CBK	9
23861	256	37N	165			498002	323	62723N-02	196	727CVN	135	80975	193	AC210CVS	8;9
261PTHN	218	4		40076N	267	5		62749N-02	196	728CVNN	135	82936	324	AC210VS	6;7
263PCALN	218	37029	263	40082N	267	507CVNN	134	62776N-02	196	729CVNN	135	800990	307	AC212BK	7
263PN	218	37060	266	40088N	267	508CVNN	134	627990	324	765	166	808000	319	AC212CBK	9
2690GP	185	37081	265	40222N	267	52910N	136	62811N-02	196	7776CVNN	133	810000	320	AC212CVS	9
27N	163	37116	265	40242N	267	5427CVNN	132	62826N-02	196	7777CVNN	133	812990	306	AC212VS	6;7
28N	163	37200	266	40248N	267	5428CVNN	132	62830N-02	196	790980	318	815990	306	AC215BK	7
29N	163	37228	266	40254N	267	5437CENN	132	62832N-02	196	790982	318	817980	320	AC215VS	7
2-651990	294	37256	265	40254N	267	5438CENN	132	62838N-02	196	791980	318	822990	306	AC218BK	7
2-652990	294	37392	263	40260N	267	552N	240	62839N-02	196	791982	318	825990	306	AC218VS	7
2-653990	294	37398	263	40281N	268	56	280	628990	324	792980	318	830990	307	AC224BK	7
2-654990	294	37404	263;264	40287N	268	572000	317	63103	195	792982	318	835990	307	AC224VS	7
2-655990	294	37416	266	4050000	321	5720020	317	63112	195	793980	318	896260	319	AC24BK	7
2-656990	294	37430	266	40580N	270	573000	317	63145	195	793982	318	896262	319	AC24CVS	9
2-658990	294	37486	265	40645N	270	573002	317	63158	195	794980	318	811990YF	306	AC24VS	7
2-681990-01	298	37500	265	40651N	270	5740000	317	63220	195	794982	318	812990F	306	AC2610CVS	8
2-682990-01	298	37591	266	40663N	270	5740020	317	63256	194;195	7924160	318	812990Y	306	AC26810CV	8
2-683990-01	298	37612	265	40667N	270	577000	317	63268	194;195	7924162	318	812990YF	306	AC26BK	7
2-684990-01	298	37619	265	40699N	270	578000	317	63280	194;195	7924240	318	815990F	306	AC26CVS	8;9
2-685990-01	298	37640	265	40705N	270	579000	317	63838	194	7924242	318	815990Y	306	AC26VS	6;7
2-688990-01	298	37752	265	40717N	270	586N	240	640990	298	7930240	318	815990YF	306	AC2812VS	6
2-689990-01	298	37767	264	410BN	168	58712N	235	646LN	228	7930242	318	821990Y	306	AC28BK	7
20-656990	295	37779	266	4100000	321	590GMEN	234	6509900	295	7936140	318	822990Y	306	AC28CBK	9
20-681990	299	37793	266	41018	266	590GMN	234	6519900	294	7936142	318	825990Y	306	AC28CVS	8;9
20-682990	299	37828	265	41102	266	590GN	234	6546CVSMLNN	136	7936160	318	86N	226	AC28VS	6;7
20L-656990	295	37842	265	41612N	268			6546NN	136	7936162	318	8690CK	187	AC3PC	6
		37849	265	41618N	268	6		6547CVNN	136	7936240	318	8690CS	186	AC610RS	15
		37863	265	41636N	268	6012INN	225	661980	309	7936242	318	8690FH	186	ACFR8VS	14
3		37891	265	42030L	262	605N	160	662980	309	7948240	318	8690FSK	186	ACL10VS	14
31300N	239	37898	266	426N	163	605990	325	663980	309	7948242	318	8690TN	187		
35025N	269	37926	266	427N	163										

Continued on next page

PRODUCT	PAGE	PRODUCT	PAGE	PRODUCT	PAGE	PRODUCT	PAGE	PRODUCT	PAGE	PRODUCT	PAGE	PRODUCT	PAGE	PRODUCT	PAGE
AL725MAGN	209	AMB1SL6-25	112	AMB2TX15-2	114	AMN1C28-1	115	AUGN2B16-1	108	C2915MME590N	233	CCW1	61;93;94;97	CDD514N	39;41;49;52;55
AL725N	209	AMB1SL8-2	112	AMB2TX15-25	114	AMN1C28-25	115	AUGN2B20-1	108	C2920MME150MN	233	CCW10	92;97	CDD515N	39;41;42;49;52;55
AL748CMEN	209	AMB1SL8-25	112	AMB2TX20-2	114	AMN1C32-1	115	AUGN2B24-1	108	C2920MME590N	233	CCW11	92;97	CDD516N	39;41;49;52;55
AMB1HM2-25	111	AMB1SQ1-2	112	AMB2TX20-25	114	AMN1C32-25	115	AUGN2B28-1	108	C2930MME590N	233	CCW12	92;97	CDD517N	39;41;42;49;52;55
AMB1HM25-25	111	AMB1SQ1-50	112	AMB2TX25-2	114	AMN1CSET-3	115	AUGN2B32-1	108	C4ASN	169	CCW13	92;97	CDD518N	41;42;49;52;55
AMB1HM3-25	111	AMB1SQ2-10	112	AMB2TX25-5	114	AMN2B16-1	115	AUGN2BSET-3	107	C5CVN	141;142	CCW14	92;97	CDD519N	39;41;42;49;52;55
AMB1HM4-25	111	AMB1SQ2-2	112	AMB2TX25-50	114	AMN2B16-25	115	AUGSET-30	107	C6CCSVN	144	CCW15	92;97	CDD51N	42;48;51;55
AMB1HM5-25	111	AMB1SQ2-50	112	AMB2TX27-50	114	AMN2B20-1	115	AUMB3BPH2-1	108	C6CCVN	144	CCW16	92;97	CDD520N	49;52;56
AMB1HM6-25	111	AMB1SQ3-50	112	AMB2TX30-2	114	AMN2B20-25	115	AUMB3BSQ2-1	108	C6NVN	141;143	CCW18	93;97	CDD523N	58;59;66;72
AMB1HMSET-6	110	AMB1TR10-25	112	AMB2TX30-50	114	AMN2B24-1	115	AUMB3BTX25-1	108	C711H	15	CCW19	61;93;94;95;96;97	CDD524N	58;59;66;72
AMB1HX10-25	111	AMB1TR15-25	112	AMB2TX40-2	114	AMN2B24-25	115			C715	15	CCW20	93;94;95;96;97	CDD525N	59;60;66;72
AMB1HX12-25	111	AMB1TR20-25	113	AMB2TX40-50	114	AMN2B28-1	115	C		C718	15	CCW21	40;43;61;93;94;95;96;97	CDD526N	40;41;59;60;62;66;72
AMB1HX14-25	111	AMB1TR25-25	113	AMB3BPH1-25	113	AMN2B28-25	115	C106PMN	219	C79H	15	CCW22	93;94;95;97	CDD527N	40;41;59;60;62;66;72
AMB1HX16-25	111	AMB1TR27-25	113	AMB3BPH2-1	113	AMN2B32-1	115	C106TPMN	219	C7CVN	141;142	CCW23	40;43;61;93;94;95;96;97	CDD528N	40;41;59;60;62;66;72
AMB1HX5-25	111	AMB1TR30-25	113	AMB3BPH2-25	113	AMN2B32-25	115	C10CVN	141;142	C7SVN	143	CCW24	40;43;61;93;94;95;96;97	CDD529N	40;41;59;60;62;66;72
AMB1HX6-25	111	AMB1TR40-25	113	AMB3BPH3-25	113	AMN616-25	115	C10SVN	143	C8SMVN	145	CCW25	43;61;93;94;96;97	CDD52N	48;51;55
AMB1HX7-25	111	AMB1TRSET-7	111	AMB3BSQ1-25	113	AMN620-25	115	C11CCSVN	144	C9212	212	CCW26	43;61;93;94;97	CDD530N	40;41;59;60;62;66;72
AMB1HX8-25	111	AMB1TX10-25	112	AMB3BSQ2-1	114	AMN624-25	115	C11CCVBN	144	C9212X	212	CCW27	93;97	CDD531N	40;41;59;60;66;72
AMB1HX9-25	111	AMB1TX15-2	112	AMB3BSQ2-25	114	AMSET-38	109	C11CCVN	144	C9NVN	141;143	CCW28	43;93;94;97	CDD532N	59;60;72
AMB1HXR10-25	112	AMB1TX15-25	112	AMB3BSQ3-25	114	AT210BK	9	C120TPN	219	C9WN	145	CCW29	93;97	CDD533N	59;60;72
AMB1HXR12-25	112	AMB1TX20-2	112	AMB3BTX25-1	114	AT210CVS	10;11	C1276DN	220	CAEAD316	105	CCW3	40;43;61;92;93;94;95;97	CDD538N	59;60;72
AMB1HXR5-25	111	AMB1TX20-25	112	AMB3BTX25-25	114	AT210SPUD	11	C1276N	220	CAEAD324	105	CCW30	93;94;97	CDD539N	40;41;59;60;66;72
AMB1HXR6-25	111	AMB1TX25-10	112	AMB6PH1-25	113	AT210VVS	9	C1278DN	220	CAEAD332	105	CCW31	93;97	CDD53N	39;41;42;48;51;55
AMB1HXR7-25	111	AMB1TX25-15	112	AMB6PH2-1	113	AT212BK	9	C1278N	220	CAEBH2C	105	CCW32	93;97	CDD540N	40;41;59;60;66;72
AMB1HXR8-25	111	AMB1TX25-2	112	AMB6PH2-25	113	AT212CVS	11	C1286DN	221	CAPW10S	18	CCW33	97	CDD541N	40;41;59;60;66;72
AMB1HXR9-25	112	AMB1TX25-30	112	AMB6PH3-25	113	AT212VVS	9	C1286N	221	CAPW14	18	CCW35	97	CDD542N	40;41;59;60;62;66;72
AMB1HXRSET-7	110	AMB1TX25-50	112	AMB6SQ1-25	114	AT215BK	10	C1288BLKN	221	CAPW14L	19	CCW4	40;43;61;92;93;94;95;97	CDD543N	40;41;59;60;62;66;72
AMB1HXSET-9	109	AMB1TX27-50	112	AMB6SQ2-25	114	AT215SPUD	11	C129012SFN	233	CAPW18	18	CCW5	40;43;61;92;93;94;95;97	CDD544N	40;41;59;60;62;66;72
AMB1PH1-2	112	AMB1TX30-50	112	AMB6SQ3-25	114	AT218BK	10	C1290SF590N	233	CAPW24	18	CCW6	43;61;92;93;94;95;97	CDD545N	40;59;60;66;72
AMB1PH1-50	112	AMB1TX40-25	112	AMB6TX25-1	114	AT24BK	9	C1291SF590N	233	CBO8B	232	CCW7	43;61;92;93;95;97	CDD546N	40;59;60;62;72
AMB1PH2-10	112	AMB2CPH1-25	113	AMB6TX25-25	114	AT24VS	9	C1293SF590N	233	CBO8BA	232	CCW8	43;92;93;95;97	CDD547N	40;59;60;62;66;72
AMB1PH2-15	112	AMB2CPH2-25	113	AMBH12-1	116	AT2610CVS	10	C1676DN	221	CBO8BL	232	CCW9	92;93;97	CDD548N	59;60;72
AMB1PH2-2	112	AMB2CPH3-25	113	AMBH12-25	116	AT26BK	9	C18CCRN	144	CBO8R	232	CCWS0	95	CDD549N	59;60;66;72
AMB1PH2-30	112	AMB2PH1-50	113	AMBH2-25	116	AT26CVS	10;11	C18CCSN	144	CBO8Y	232	CCWS1	96	CDD54N	39;41;48;51;55
AMB1PH2-50	112	AMB2PH2-1	113	AMBH3-1	116	AT26VS	9	C20CHN	145	CB25B	232	CCWS2	93	CDD555N	81
AMB1PH3-2	112	AMB2PH2-15	113	AMBH3-25	116	AT28BK	9	C213CN	218	CB25BA	232	CCWS3	94	CDD556N	76;81
AMB1PH3-50	112	AMB2PH2-5	113	AMBH6-1	116	AT28CVS	11	C213CXN	218	CB25R	232	CCWS4	92	CDD557N	76;81
AMB1PH4-25	112	AMB2PH2-50	113	AMBH6-25	116	AT28VS	9	C213DN	218	C8B	166	CCWS5	93	CDD558N	76;81
AMB1PT1-50	112	AMB2PH3-50	113	AMBQ2A-1	116	ATWJ210VS	13	C21616THBLKN	218	CBSSDN	67	CCWS9BM	92	CDD559N	76;81
AMB1PT2-2	112	AMB2SL4-25	113	AMBQ2A-25	116	ATWJ212VS	13	C216DN	218	CBSS1N	67	CCWS9BS	91	CDD55N	39;41;42;48;51;55
AMB1PT2-50	112	AMB2SL6-25	113	AMDG3-1	114	ATWJ2610VS	13	C2276DN	221	CBSS2N	45	CCWSRMM7	95	CDD560N	76;81
AMB1PZ1-25	113	AMB2SL8-1	113	AMDG3-25	114	ATWJ26VS	13	C2276MEN	221	CBSS2TN	45	CCWSRSAE7	94	CDD561N	76;81
AMB1PZ2-25	113	AMB2SL8-25	113	AMN1C16-1	115	ATWJ28VS	13	C2730MMEN	220	CCA20509	139	CD2730DMMN	221	CDD562N	76;81
AMB1PZ3-25	113	AMB2SQ1-50	113	AMN1C16-25	115	AUGB3BPH2-1	108	C2730MMN	220	CCA5428	139	CD2750MMEN	221	CDD563N	76;81
AMB1SL1-25	112	AMB2SQ2-1	114	AMN1C20-1	115	AUGB3BSQ2-1	108	C2750DMMN	220	CCFWSN	101	CDDSON	51;55	CDD564N	81
AMB1SL2-25	112	AMB2SQ2-5	114	AMN1C20-25	115	AUGB3BTX25-1	108	C2750MMECALN	220	CCFWS1N	101	CDD511N	48;52;55	CDD565N	81
AMB1SL3-25	112	AMB2SQ2-50	114	AMN1C24-1	115	AUGBH3-1	105	C2750MMEN	220	CCP8V	146	CDD512N	48;52;55	CDD566N	81
AMB1SL4-25	112	AMB2SQ3-50	114	AMN1C24-25	115	AUGBQ2A-1	105	C2910MME590N	233	CCWO	61;93;94;97	CDD513N	39;41;42;48;52;55		

Continued on next page

PRODUCT	PAGE	PRODUCT	PAGE	PRODUCT	PAGE	PRODUCT	PAGE	PRODUCT	PAGE	PRODUCT	PAGE	PRODUCT	PAGE
CDS67N	81	CDS25N	39;41;43;44;59;60;61;62;63;64;65;71	CDS53N	40;74;75;80	CDTA14N	47	CHKFSAE9	31	CIPW18	19	CND10M	29;30
CDS6N	39;41;48;51;55	CDS26N	39;41;42;43;44;59;60;61;62;63;64;65;71	CDS54N	40;74;75;80	CDTA15MDN	46	CHKFT8	31	CJB635990	291	CND1132	29
CDS71N	77;81	CDS27N	39;41;42;43;44;59;60;61;62;63;64;65;71	CDS55N	40;74;75;80	CDTA15N	70	CHKLABALL13	32	CJB636990	291	CND11M	30
CDS72N	77;81	CDS28N	39;41;42;43;44;59;60;61;62;63;64;65;71	CDS56N	40;75;80	CDTA16N	46;47;54	CHKLASAE13	32	CJB637990	291	CND12	29
CDS73N	77;81	CDS29N	39;41;42;43;44;59;60;61;62;63;64;65;71	CDS57N	40;74;75;80	CDTA17N	46;47;59;71	CIMBS11N	88	CJB638990	291	CND14	28;29
CDS74N	77;81	CDS30N	39;41;42;43;44;59;60;61;62;63;64;65;71	CDS58N	40;74;75;80	CDTA18N	79	CIMSON	86	CJCW0	96	CND316	28;29
CDS75N	81	CDS31N	39;41;42;43;44;59;60;61;62;63;64;65;71	CDS59N	40;74;75;80	CDTA1N	42;43;44;46;47;70	CIMS10N	86;90	CJCW1	96	CND38	28;29
CDS76N	77;81	CDS32N	39;42;44;59;60;61;62;64;71	CDS5N	39;41;42;43;44;47;48;49;50;54	CDTA2N	46;70	CIMS11N	86;90	CJCW2	96	CND516	28;29
CDS77N	77;81	CDS33N	42;59;64;71	CDS60N	40;74;75;80	CDTA3N	46;80	CIMS12N	87;90	CJCW3	96	CND5M	30
CDS78N	77;81	CDS37N	39;41;61;71	CDS61N	74;75;80	CDTA4N	46;80	CIMS13N	87;90	CJCW4	96	CND5MM	29
CDS7N	39;41;42;48;51;55	CDS38N	39;41;59;60;61;71	CDS62N	75;80	CDTA5N	85	CIMS14N	87;90	CJCW5	96	CND5SAEN	28
CDS80N	77;81	CDS39N	39;41;59;60;61;62;65;71	CDS63N	80	CDTA6N	43;46;47;53	CIMS15N	87;90	CJCW6	96	CND6M	29;30
CDS8N	39;41;42;48;51;55	CDS3N	39;41;42;43;44;47;48;49;50;54	CDS64N	80	CDTA7N	46;48;53	CIMS16N	87;90	CJCW7	96	CND716	28;29
CDS9N	48;51;55	CDS40N	39;41;43;44;59;60;61;62;63;64;65;71	CDS66N	80	CDTA8N	39;40;42;43;44;46;58;59;60;61;62;70	CIMS17N	87;90	CJCW8	96	CND7M	29;30
CDS0N	39;41;42;43;44;48;49;50;54	CDS41N	39;41;43;44;59;60;61;63;64;65;71	CDS6N	39;41;42;43;44;47;48;49;50;54	CDS6N	39;41;42;43;44;47;48;49;50;54	CIMS18N	87;90	CJCW9	96	CND8M	29;30
CDS100N	82;83;85	CDS42N	39;41;42;43;44;59;60;61;62;63;64;65;71	CDS72N	76;80	CDS72N	76;80	CIMS19N	87;90	CL100B	231	CND9M	29;30
CDS101N	83;85	CDS43N	39;41;42;43;44;59;60;61;62;63;64;65;71	CDS73N	76;80	CDS73N	76;80	CIMS1N	87	CL100R	231	CP0212	21;22;24
CDS102N	83;85	CDS44N	39;41;42;43;44;59;60;61;62;63;64;65;71	CDS74N	76;80	CDS74N	76;80	CIMS20N	87;90	CL150	231	CP1112	21;22;24
CDS103N	86	CDS45N	40;41;42;43;44;59;60;61;62;63;64;65;71	CDS75N	76;80	CDS75N	76;80	CIMS21N	87;90	CL50	230	CP13	21;22;24
CDS104N	83;86	CDS46N	40;41;42;44;59;60;61;62;63;64;65;71	CDS76N	80	CDS76N	80	CIMS22N	87;90	CLA100	230	CP2112	21;24
CDS105N	83;86	CDS47N	40;41;42;43;44;59;60;61;62;63;64;65;71	CDS77N	76;80	CDS77N	76;80	CIMS23N	87;90	CLA100A	230	CP24N	21;22;24
CDS106N	83;86	CDS48N	40;41;42;44;59;60;61;62;63;64;65;71	CDS78N	76;80	CDS78N	76;80	CIMS24N	87;90	CLA100AB	230	CP26	21;22;24
CDS107N	83;86	CDS49N	40;41;42;44;58;60;61;62;63;65;71	CDS79N	76;80	CDS79N	76;80	CIMS25N	87;90	CLA100B	230	CP28	21;24
CDS11N	39;41;42;43;44;48;51;54	CDS4N	39;41;42;43;44;47;48;49;50;54	CDS7N	39;41;42;43;44;47;48;49;50;54	CDS7N	39;41;42;43;44;47;48;49;50;54	CIMS26N	87;90	CLA100R	230	CP36	24
CDS12N	39;41;42;43;44;47;48;50;51;55	CDS51N	71	CDS80N	80	CDS80N	80	CIMS27N	87;90	CL0100	231	CP48	24
CDS13N	39;41;42;43;44;47;49;50;51;55	CDS52N	71	CDS81N	76;80	CDS81N	76;80	CIMS28N	88;91	CLP100	231	CP4PCSET	22
CDS14N	39;41;42;43;44;47;49;50;51;55	CDS53N	71	CDS82N	80	CDS82N	80	CIMS29N	88;91	CLP100B	231	CPK325A	173
CDS15N	39;41;42;43;44;47;49;50;51;55	CDS54N	71	CDS84N	80	CDS84N	80	CIMS2N	87	CLP100R	231	CPK325C	174
CDS16N	39;41;42;43;44;47;49;50;51;55	CDS55N	71	CDS87N	81	CDS87N	81	CIMS30N	88;91	CLP2SETN	142	CPK350A	173
CDS17N	39;41;42;43;44;47;49;50;51;55	CDS56N	71	CDS8N	39;41;43;44;47;48;49;50;54	CDS8N	39;41;43;44;47;48;49;50;54	CIMS31N	88;91	CLP3SETN	141	CPK350C	174
CDS18N	39;41;42;43;44;47;49;50;51;55	CDS57N	71	CDS91N	83;85	CDS91N	83;85	CIMS32N	88;91	CLP5SETN	141	CPS20PCSET	21
CDS19N	39;41;43;44;47;49;50;51;55	CDS58N	71	CDS92N	83;85	CDS92N	83;85	CIMS33N	88;91	CN129012SF5N	233	CPS6PCSET	22
CDS1N	39;41;42;43;44;47;48;49;50;54	CDS59N	71	CDS93N	83;85	CDS93N	83;85	CIMS34N	88;91	CN1290SF590N	233	CPTAW8	16
CDS20N	39;41;44;47;48;50;51;55	CDS60N	71	CDS94N	83;85	CDS94N	83;85	CIMS35N	88;91	CN1290SMEN	233	CPW12	20
CDS23N	39;41;59;60;61;65;71	CDS61N	71	CDS95N	83;85	CDS95N	83;85	CIMS3N	88	CPW12S	21	CPW16S	21
CDS24N	39;41;44;59;60;61;62;63;65;71	CDS62N	71	CDS97N	82;83;85	CDS97N	82;83;85	CIMS4N	86;90	CRTW12	102	CPW12S	21
		CDS63N	71	CDS98N	82;85	CDS98N	82;85	CIMS5N	86;90	CRTW38	102	CRW0N	39;40;42;43;47;48;49;50;52
		CDS64N	71	CDS99N	82;85	CDS99N	82;85	CIMS6N	86;90	CRW1	53	CRW10	69
		CDS66N	71	CDTA0N	46;54	CDTA0N	46;54	CIMS7N	86;90	CRW11	68	CRW12	77
		CDS67N	71	CDTA10N	46;70	CDTA10N	46;70	CIMS8N	86;90	CRW12EXT	78	CRW12N	39;74;75;77
		CDS68N	71	CDTA11N	74;75;79	CDTA11N	74;75;79	CIMS9N	86;90	CRW13	78	CRW14	78
		CDS69N	71	CDTA12N	39;46;79	CDTA12N	39;46;79	CIMS10N	86;90	CRW14	78		
		CDS70N	71	CDTA13N	46;79	CDTA13N	46;79	CIMS11N	86;90				
		CDS71N	71					CIMS12N	87;90				
		CDS72N	71					CIMS13N	87;90				
		CDS73N	71					CIMS14N	87;90				
		CDS74N	71					CIMS15N	87;90				
		CDS75N	71					CIMS16N	87;90				
		CDS76N	71					CIMS17N	87;90				
		CDS77N	71					CIMS18N	87;90				
		CDS78N	71					CIMS19N	87;90				
		CDS79N	71					CIMS1N	87				
		CDS80N	71					CIMS20N	87;90				
		CDS81N	71					CIMS21N	87;90				
		CDS82N	71					CIMS22N	87;90				
		CDS84N	71					CIMS23N	87;90				
		CDS87N	71					CIMS24N	87;90				
		CDS8N	71					CIMS25N	87;90				
		CDS91N	71					CIMS26N	87;90				
		CDS92N	71					CIMS27N	87;90				
		CDS93N	71					CIMS28N	88;91				
		CDS94N	71					CIMS29N	88;91				
		CDS95N	71					CIMS2N	87				
		CDS97N	71					CIMS30N	88;91				
		CDS98N	71					CIMS31N	88;91				
		CDS99N	71					CIMS32N	88;91				
		CDTA0N	71					CIMS33N	88;91				
		CDTA10N	71					CIMS34N	88;91				
		CDTA11N	71					CIMS35N	88;91				
		CDTA12N	71					CIMS3N	88				
		CDTA13N	71					CIMS4N	86;90				
			71					CIMS5N	86;90				
			71					CIMS6N	86;90				
			71					CIMS7N	86;90				
			71					CIMS8N	86;90				
			71					CIMS9N	86;90				
			71					CIMS10N	86;90				
			71					CIMS11N	86;90				
			71					CIMS12N	87;90				
			71					CIMS13N	87;90				
			71					CIMS14N	87;90				
			71					CIMS15N	87;90				
			71					CIMS16N	87;90				
			71					CIMS17N	87;90				
			71					CIMS18N	87;90				
			71					CIMS19N	87;90				
			71					CIMS1N	87				
			71					CIMS20N	87;90				
			71					CIMS21N	87;90				
			71					CIMS22N	87;90				
			71					CIMS23N	87;90				
			71					CIMS24N	8				

PRODUCT	PAGE	PRODUCT	PAGE	PRODUCT	PAGE	PRODUCT	PAGE	PRODUCT	PAGE	PRODUCT	PAGE	PRODUCT	PAGE
CSPS1N	74	CTK84CMPN	42	FM050CM	216	L		M3R	150	OS1291F590N	236	PHV1430N	211
CSPS2N	44;61;62;74	CW10T	160	FM050CME	216	L06CS	223	M3X	153	OS1293F590N	236	PHV1433DMN	211
CSPS3N	82	CW10TL	160	FM060CME	216	L0812US	224	M400N	155	OY100	238	PHV1433N	211
CSPS4N	82	CW10TM	159	FM100CME	216	L1016C	207	M45RS	286	OY50	238	PQR1312N	210
CSRO	56	CW11TM	159			L1025C	207	M4RN	154			PQR1316N	210
CSR1	74	CW12H	16	G		L1025CB	207	M5R	150	P		PQR1425N	210
CSR2	82	CW15	16	GG010HNN	135	L1025CD	207	M6R	151	P2133DN	211	PS1806DN	216
CSWS10N	58;59	CW24	16	GG014HNN	135	L1025CME	207	M7R	151	P2210MEXN	211	PS1806N	216
CSWS11N	74;75	CW5T	160			L1030C	207	M80SS	152	P2212XN	211	PS1808DN	216
CSWS12N	75	CW7T	158	H		L1035C	207	M810	279	P2335MEN	211	PS1808N	216
CSWS13N	44	CW812S	158	H26N	137	L1035CME	207	M812	279	PAC1357000	312	PS1809DN	216
CSWS14MM12	50	CWGLRG	283	H26VN	137	L1108B	207	M88	279	PAC1357002	312	PS20509C	137;138
CSWS14SAE12	49	CWGME0	283	H28N	137	L1116	206	MPC3SN	155	PAC1580000	313	PS5429C	137;138
CSWS1N	47	CWGXLG	283	H28VN	137	L1116B	206	MPX5	154	PAC1580002	313	PS6549C	138
CSWS2N	48	CX6DBM2	99	HC253N	218	L1116CME	206			PAC1582000	313	PSC1455000	314
CSWS38B	57	CX6DBS2	99	HC256N	218	L1125	206	N		PAC1582002	313	PSC1455002	314
CSWS38MM10	64	CX6PT20	58	HD403DN	217	L1125B	206	NP11	279	PAC1585000	313	PSC1456000	314
CSWS38SAE10	63	CX6RWM7	98	HD403N	217	L1125CME	206	NS503N	191	PAC1585002	313	PSC1456002	314
CSWS3N	48;49	CX6RWS7	98	HD406DN	217	L1135	206	NSP1	191	PAC1596000	313	PSC1457000	314
CSWS6N	64			HD406N	217	L1135B	206	NSP2	191	PAC1596002	313	PSC1457002	314
CSWS7N	62;63	D		HDH406DN	217	L1135CME	206	NSP5	191	PAH1420000	321	PSC1458000	314
CSWS8N	59;60	DB12NP	280	HDH406N	217	L12CS	223	NSP9	192	PAH1420002	321	PSC1458002	314
CSWS9N	60	DB16	278	HTZ26	129	L1624CS	224			PAH1424000	321	PSC1460000	315
CT103	21;26	DB18X	278	HTZ26CG	129	L1624RS	224	Q		PAH1424002	321	PSC1460002	315
CT153	21;23;26	DB24	278	HTZ28	129	L48DS	223	Q120PN	235	PAN1441000	316	PSCA2SET	137
CT203	21;23;26	DB30X	278	HTZ28CG	124;129	L610CMEN	210	Q1290SF590N	237	PAN1441002	316	PSFE100	215
CT254	21;23;26	DHC1450000	311	HW100	220	L610N	210	Q1293SF590N	237	PAN1442000	316	PSFE200	215
CT274	26	DKB446X	278	HW223	219	L616CMEN	210	Q261PTHN	237	PAN1442002	316	PSFE300	215
CT304	21;23;26	DYH1453002	319	HW223D	219	L616N	210	PHV1010N	211	PHV1010N	211	PSFM030CME	215
CT4PCSET	23			HW223ME	219	L625CMEN	210	PHV1012N	211	PHV1012N	211	PSFM060CME	215
CT63	26	F		HW226	219	L625N	210	PHV1023CMEN	211	PHV1023CMEN	211	PSFM100CME	215
CTB1000	290	FB13	279	HW226D	219	L725MAG	209	OC129012SF59N	236	PHV1023CMN	211	PSMW18N	214
CTB1410	289	FB15	279	HW226ME	219	L725SCTMPN	210	OC1290SF590N	236	PHV1024CMEN	211	PSMW28CL	214
CTB1450	289	FB7	279	HW227CME	219	L748MAG	209	OC1291SF590N	236	PHV1034CMEN	211	PSMW48CL	214
CTB1710	289	FE050	216	HW50	220	L912	209	OC213DN	235	PHV1034DMN	211	PSMW48N	214
CTB1750	289	FE050D	216	HX46N	227	L916L	209	OC2276DN	238	PHV1035CMEN	211	PSMW48NM	214
CTB2010	290	FE100	216	HYT100	215	L925L	209	OC2276MEN	238	PHV1035CMN	211	PSN1451000	316
CTBR1850	291	FE100D	216	HYT100D	215	L930L	209	OC2910MME590N	236	PHV1048CMEN	211	PSN1451002	316
CTK121	40;41	FE150	216	HYT15CME	215	L935L	209	OCN129012SF5N	236	PHV1048CMN	211	PSN1452000	316
CTK128MP2N	61	FE150D	216	HYT30CME	215	LSSP6-07	223	OCN1290SF590N	236	PHV1048DMN	211	PSN1452002	316
CTK142	39;40	FE200	216	HYT50	215			OCN1291SF590N	236	PHV1049CMEN	211	PSX200C	140
CTK14SAEN	83	FE200D	216	HYT50CME	215	M		OCN1293SF590N	236	PHV1312DN	211	PSX201C	140
CTK150	36;37;38	FE300	216			M1R	149	OCN1293SMEF5N	236	PHV1312N	211	PSX204C	140
CTK16ASET	46	FE300D	216	J		M1RS1	156	OCN1294SF590N	236	PHV1316N	211	PWC9	184
CTK180	34;35;36	FM015CME	216	J7SN	169	M1X	152	OCN1294SMEF5N	236	PHV1410CMEN	211		
CTK21SAEN	82;83	FM030CM	216			M2R	149	OCN1295SF590N	236	PHV1425DN	211	S	
CTK30SETN	62	FM030CME	216	K		M2X	153	OCN1296SF590N	236	PHV1425EDN	211	S1291F590N	234
CTK70MPN	43	FM030DM	216	KSRN	168	M300N	154	OCN1296SMEF5N	236	PHV1425N	211	S1293F590N	234

Continued on next page

PRODUCT	PAGE	PRODUCT	PAGE	PRODUCT	PAGE	PRODUCT	PAGE
S590N	234	T37584	266	W20	162	WHCS2	161
ST100	217	T37598	266	W20LH	162	WHN1N	284
I		T37626	265	W20P	163	WK500V	176
T01590	256	T37647	265	W20SP	165	WK8V	175
T01630	256	T37703	266	W20W	164	WK9V	176
T01765	256	T37755	264	W22N	162	WKAR2	175
T01888	256	T37761	264	W22P	163	WKF2	175
T01891	256	T37786	266	W22W	164	WRPCLG	285
T01974	256	T37800	266	W30	165	WS19H	145
T066N	228	T37807	265	W393	213	WS3N	284
T1260N	224	T37814	265	W606	213	WS4N	284
T13196	247;255	T37821	265	W606ME	213	WS6N	284
T150MMN	235	T37835	265	W606P	213	WSLP1	286
T21455	247;272	T37870	265	W606PD	213	WSR1N	286
T21484	273	T37919	266	W606PM	213	WT1	285
T21502	273	T37954	266	W608	213	X	
T31100N	238	T37961	266	W6110	212	X46FN	227
T31200N	239	T37975	265	W616	212	X48N	227
T33001	271	T37982	265	W61680	212	Y	
T33007	271	T37989	265	W8BLT	165	Y1276DN	220
T33016	271	T37996	265	W8TA	162	Y613ME	212
T33024	271	T38003	265	W912	161	Y8210	212
T35976	267	T38010	265	W9210	212	Y8212	212
T35982	267	T38115	265	W9210ME	212	Z	
T36054	267	T38N	165	W9212	212	Z20508	127
T37035	264	T41096	266	W928	212	Z20508CG	124;127
T37053	266	T584N	240	W9312	212	Z20509	127
T37088	265	T636N	226	W9312D	212	Z20509CG	124;127
T37109	265	T656N	227	WAL13S	171	Z2SET3CG	124
T37165	265	T703	217	WC3SN	283	Z2SET5CG	124
T37172	266	T764	166	WC5LN	283	Z5426	125
T37193	266	TC1	167	WC5SN	283	Z5426CG	125
T37221	266	TC213N	218	WCSET3CMNNN	259	Z5428	125
T37249	265	TC5	167	WDF100	170	Z5428CG	124;125
T37277	265	TG4N	274	WDF100	170	Z6546	125
T37423	266	TT40506	269	WDF10S	169	Z6546CG	127
T37444	265	TT524N	226	WDF12D	170	Z6548	125
T37451	265	TT590N	234	WDF12S	169	Z6548CG	124;127
T37458	265	TX46N	227	WDF168D	171	Z	
T37472	265	W		WDF7S	169	Z20508	127
T37479	265	W1225	164	WEZSNIP	162	Z20508CG	124;127
T37556	266	W1225HLSP	163	WF12	285	Z20509	127
T37563	266	W1226	164	WF18	285	Z2SET3CG	124
				WF24	285	Z2SET5CG	124





Trusted by the Trades.

ATG-5625 | ©2021



Crescent®, Wiss®, Lufkin®, Nicholson®, H.K. Porter®, JOBOX®, and APEX® are registered trademarks of Apex Brands, Inc., A Division of Apex Tool Group, LLC.

Apex Tool Group, LLC
1000 Lufkin Road, Apex, NC 27539
www.crescenttool.com